



U716 Series

Channel Frame Mirror & Shelf Combination

Revision 11/15

JOB #:

ITEM #:

QUANTITY:

MOUNTING	HANDING	TYPE	SIZE	OTHER

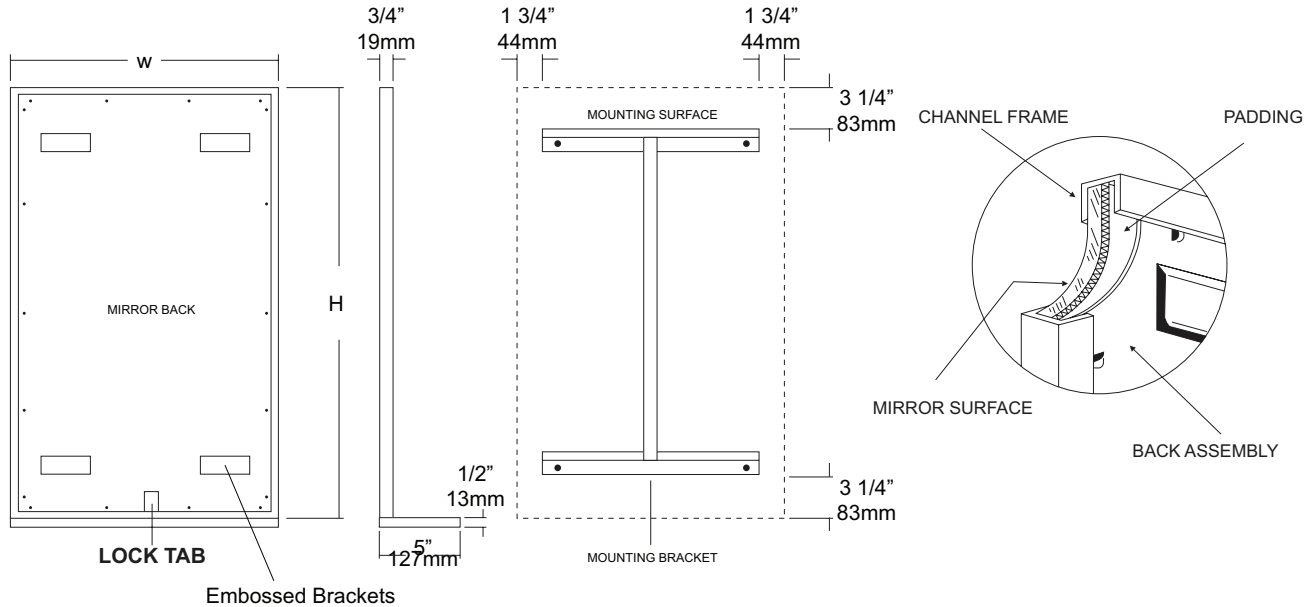

SPECIFICATIONS

Frame: Fabricated of #20 ga stainless steel, #4 satin finish. Roll formed 1/2" x 1/2" x 1/2" channel frame has mitered corners and secured with stainless steel rivet.

Mirror: 1/4" thick type 1 transparent flat type, class 1 - clear glass mirrors. Mirror is coated with silver and sealed with a uniform electrolytic copper plating, along with two coats of paint for added protection. Mirrors are guaranteed against silver spoilage for a period of 15 years. Mirrors conform to ASTM C1036 and ASTM C1503-R8.

Filler: Full size, 1/8" shock absorbing, water resistant, nonabrasive, polyethylene padding protects all concealed mirror surfaces.

Shelf: #18 ga stainless steel with #4 satin finish. Shelf is 5"d x full mirror width. All edges are turned down 1/2" with front turned back 1/2" for rigidity. #18 ga support bracket is welded to both frame and shelf, ground smooth.

Back: Fabricated of #20 ga pre-plated galvanized steel, with embossed horizontal louver mounting brackets. Embossed theft resistant pressure activated clip lock device, locks mirror in place to wall hangers.

Hangers: Fabricated of #20 ga pre-plated steel galvanized steel with mounting points.

Standard Sizes Available (W x H): 16"x24", 16"x30", 18"x24", 18"x30", 18"x36", 24"x30", 24"x36

Options:

- LG: Laminated Glass
- LX: Polycarbonate
- PM: Plastic Acrylic
- T: Tempered Glass
- VC: Vinyl Clad (Safety Glass)
- 8B: #8 Reflective Stainless Steel

*Stainless steel mirrors reflect images in different optic quality than plate glass. There will be a slight distortion which increases proportionately with the mirror size. Therefore, AJW Architectural Products™ cannot be held responsible for quality of image.

**Mirrors are always ordered Width x Height
 ***Recommended max size for 8B mirrors: 72" x 47-1/2"
 ****Framed mirrors are fabricated to a tolerance of (+/-) 1/8"
 ***** Mirrors conform to Federal Specifications DD-M-00411b & DD-g-541D

INSTALLATION

Coordinate installation with architect / contractor for specific mounting location and height for each mirror application. Making sure "I" bracket is level, transfer all mounting point locations to wall surface from drawing. Secure brackets with proper fasteners for each application. Slide mirror down over horizontal brackets until clip lock secures mirror in place. Mirror can only be removed by inserting tool through hole at bottom of frame depressing clip. This will allow mirror to slide up over brackets. Fillers are available if mirrors are mounted above and below tile line. (U004 Filler) filler material will match mirror frame to form a one piece construction.

To meet ADA Code, bottom edge of reflective surface can be no higher than 40" above finished floor. (4.19.6) Full length mirrors may be used for universal application when installed in correct locations.

Abrasive cleaners & chloric solutions should not be used on mirrors. Discoloring and /or scratching of frame and reflective surface may occur.

NOTES

Formerly Model #: U715 Series