

Specifications

- **Body:** Backs constructed of mild cold rolled 18 ga. commercial grade steel. Bottom, sides, top, and shelves constructed of 16 ga. stainless steel. Bottoms have two welded reinforcement channels. Bolt spacing shall not exceed 9" on center.
- **Frame:** Open front, with diamond ventilation pattern on sides.
- **Finish:** Commercial grade steel cleaned and treated with a phosphate process. Finished coat baked on, powder coated enamel.
- **Color:** Doors and exposed body parts available in colors from AJW standard color selection.
- **Overhead Security Locker:** 14 ga. commercial grade steel door, with 16 ga. commercial steel side panel. Door riveted to frame with continuous full length hinge or five knuckle hinge pair. Single Point Latch available -- 11 ga. Steel hook with padlock hasp welded to door frame. Padlock hasp protrudes through stainless steel cup. 16 ga. commercial grade steel frame, channel shaped, with vertical sides having an additional flange to act as a continuous door strike. Each door shall have a polished aluminum number plate riveted to the face of the door with ½" high black numerals.
- **Foot Locker:** Single point latch with padlock strike plate on front panel. Mini louvers on front panel for ventilation. Continuous full length hinge on locker top, with rubber silencers at contact points. Two reinforcement channels welded to bottom of seat, with two seat supports attached to either side for additional support.
- **Interior:** Two wall hooks and one coat rod.

Tops

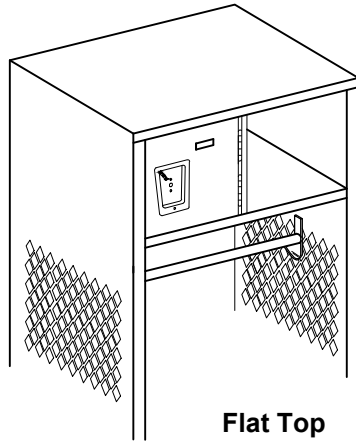

Flat Top

18 Ga. commercial grade steel, powder coated to match locker color. Continuous slope tops up to 72" in length. (Longer lengths connected with slip joints at splice locations.)

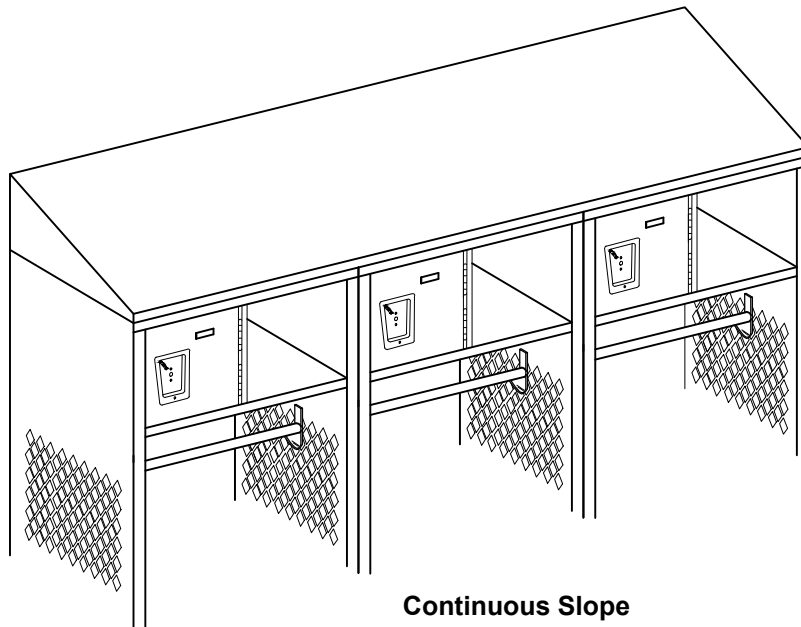

Continuous Slope

Fillers - Vertical

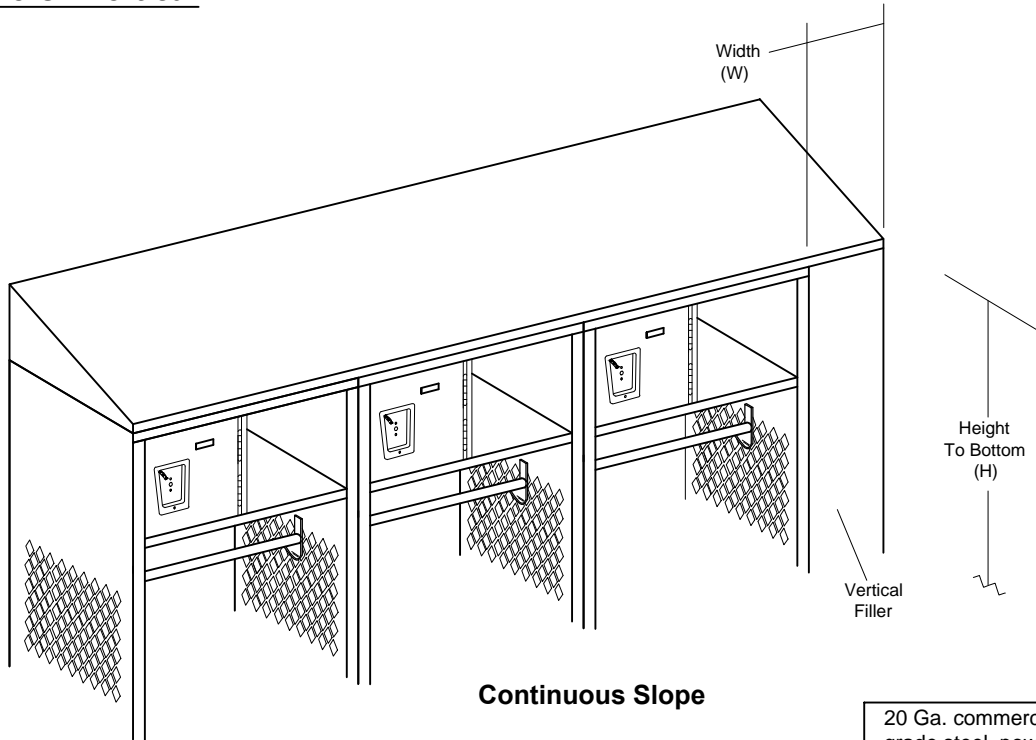

20 Ga. commercial grade steel, powder coated to match locker color. Fillers formed into an angle and connected with slip joints to create a smooth finish.

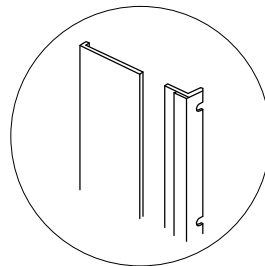

Slip Joint Detail

Coat Rod & Hook

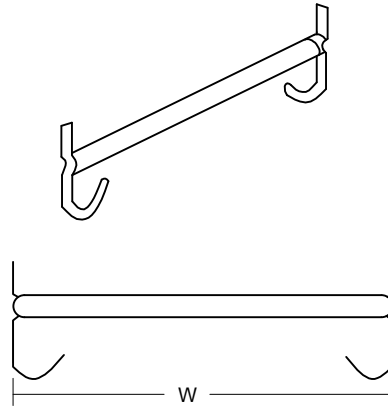

Number Plate

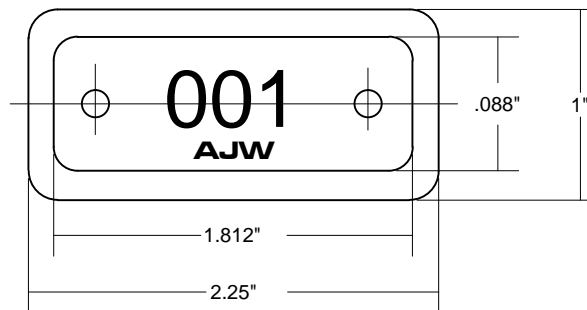

Standard Series

(W x D)	One Tier				Two Tier		Three Tier		Four Tier		Five Tier	Six Tier	2 Person
	36" H	48" H	60" H	72" H	60" H	72" H	60" H	72" H	60" H	72" H	60" H	72" H	72" H
12" x 12"	•	•	•	•	•	•	•	•	•	•	•	•	
12" x 15"	•	•	•	•	•	•	•	•	•	•	•	•	
12" x 18"	•	•	•	•	•	•	•	•	•	•	•	•	
15" x 15"			•	•	•	•	•	•			•	•	•
15" x 18"			•	•	•	•	•	•			•	•	•
18" x 18"			•	•	•	•	•	•			•	•	•

All heights are measured from flat top to flat bottom of locker. 6" legs available on all Standard Series lockers (add 6" to all heights above).

Athletic Series

(W x D)	One Tier		Two Tier		Three Tier		Four Tier		Five Tier	Six Tier
	60" H	72" H	60" H	72" H	60" H	72" H	60" H	72" H	60" H	72" H
12" x 12"	•	•	•	•	•	•	•	•	•	•
12" x 15"	•	•	•	•	•	•	•	•	•	•
12" x 18"	•	•	•	•	•	•	•	•	•	•
15" x 15"	•	•	•	•	•	•	•	•	•	•
15" x 18"	•	•	•	•	•	•	•	•	•	•
18" x 18"	•	•	•	•						
18" x 21"	•	•								
18" x 24"	•	•								
24" x 18"	•	•	•	•						
24" x 21"	•	•	•	•						
24" x 24"	•	•	•	•						

All heights are measured from flat top to flat bottom of locker. 6" legs available on all Athletic Series lockers (add 6" to all heights above).

Professional Series

(W x D)	One Tier
	72" H
24" x 18"	•
24" x 21"	•
24" x 24"	•
33" x 18"	•
33" x 21"	•
33" x 24"	•

Continuous Slope Tops

72" W (Std)	
D	H
12"	5"
15"	6"
18"	7"
21"	8"
24"	9"

Z-Bases

72" W x 4" H Front Base	
End / Splice Depth	12"
	15"
	18"
	21"
24"	
<i>Field cut front base as necessary.</i>	

Front & Closed Ends

Available W x D Combinations		
W	D	Size W x D x H
12"	12"	
15"	15"	
18"	18"	
24"	21"	
	24"	
6" H (Std)		

Trim for Recessed Lockers

L / R Side Trim	
W	H
3"	63"
	75"
Top Trim	
74" W x 3" H	
Splice	
2" W x 3" H	

Fillers

W	H
6"	60"
	66"
	72"
	78"
12"	60"
	66"
	72"
	78"