

date  
projectname  
attn  
from  
fax  
email  
phone

01-08-2018  
NMH  
vineeth  
al ahlia



# U155 Soap Dispenser

Revision 03/11

JOB #:

ITEM #:

QUANTITY:

MOUNTING	HANDING	TYPE	SIZE	OTHER

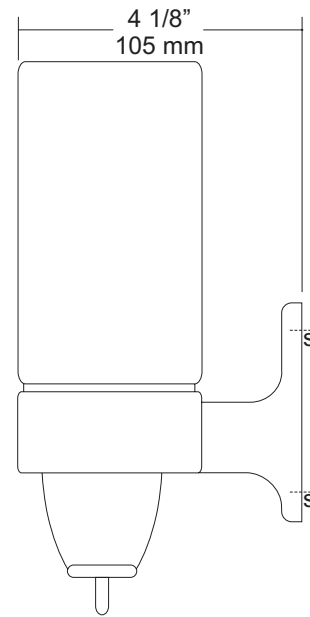
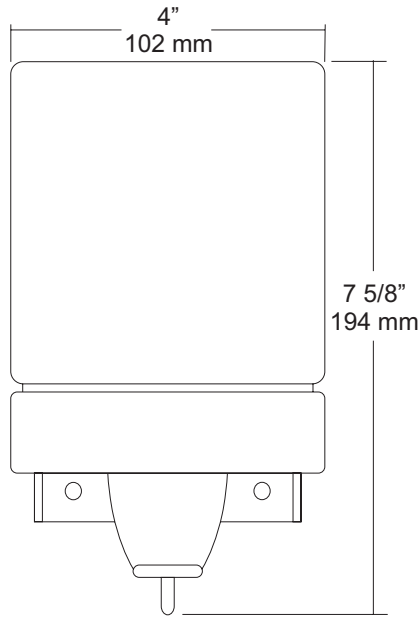

### SPECIFICATIONS

**Globe:** Fabricated of translucent, shatterproof, corrosion resistant polyethylene with a smooth curved design.

**Valve:** Fabricated of high impact plastic, corrosion resistant ABS material with a stainless steel return spring. Dispenses pre-measured amounts of soap to prevent waste. Valve will dispense most liquids and lotions. (Not pumice soaps) Push up type valve requires less than 5 lbs of force to operate. When properly mounted dispenser will comply with ADA code.

**Mounting Bracket & Valve Cover:** Fabricated of highly polished chrome plated ABS material.

**Overall Size:** 4"W x 7 5/8"H x 4 1/8"D

**102mm x 194mm x 105mm**

**Capacity:** 24 fluid oz.

### INSTALLATION

If mounting on wall surface, transfer mounting hole dimensions as shown on drawing. Drill pilot holes and secure unit to surface with proper fasteners. Push up valve cannot be any higher than 40" above finished floor to comply with ADA code.

\*It is not recommended to mount any soap dispenser on mirrors

\*\*For best performance, use pre-mixed low concentrate solutions. Dispensers should have periodic maintenance performed to insure the life of the dispenser. Rinse out tank and valve with warm water to prevent sludge buildup.

Preventative Maintenance: Each dispenser should be flushed out aprx. Every 30 days with warm water to prevent valve from clogging with old soap. Do not use abrasive cleaners to clean dispenser.

### NOTES



# U199EA

## Roll Towel Dispenser

Revision 01/12

JOB #:

ITEM #:

QUANTITY:

MOUNTING	HANDING	TYPE	SIZE	OTHER

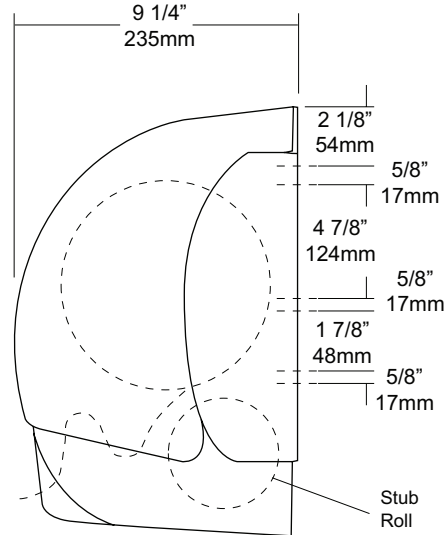
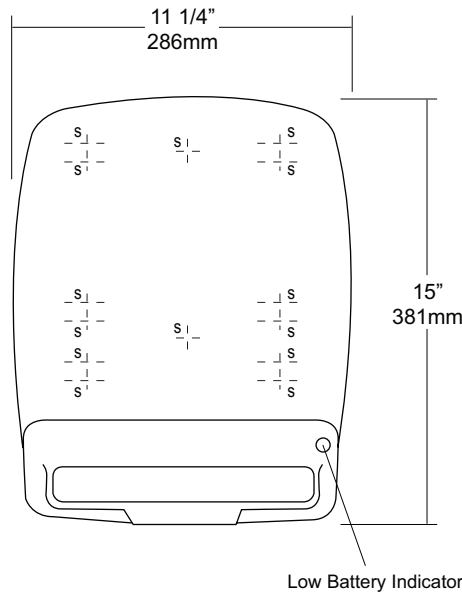

### SPECIFICATIONS

**Cabinet Body:** Fabricated of high impact plastic.

**Cover:** Fabricated oh high impact translucent plastic. Cover is secured with a special keyed lock.

**Mechanism:** Internal mechanism is fabricated of high impact plastic operated by an automatic sensor with auto transfer system

**Automatic Sensor:** Is operated by four (4) D-cell batteries that are not included. After batteries and paper has been properly loaded, pass hands through sensor range to activate motor. After the unit has 30 seconds to calibrate, It is ready to dispense paper. It takes aprx. 6 dispenses to adjust to the proper paper length. After the sensor range has been interrupted, paper will not be dispenser until the sensor range has been cleared to reset. Three pre-length settings for paper and three, time delay settings for dispensing paper.

**Overall Size:** 11 1/4"W x 15"H x 9 1/4"D

**Capacity:** One standard size roll of 8" or 9" wide. (Use only non-perforated towels). One stub roll up to 2 3/4" OD

**Power Requirements:** The unit operates with four (4) "D" size alkaline batteries only. Other type of batteries are not recommended

### INSTALLATION

Open cover and hold unit on wall surface at desired or specified location. Transfer mounting points to wall surface and provide pilot holes. Install batteries per instructions and snap protective cover over batteries. Secure cabinet to wall surface with proper anchoring devices per application.

Install paper towel per directions inside cabinet and secure cover, checking for proper operation. This hands free dispensing method will minimize cross contamination of the remaining towels inside the cabinet.

### NOTES



**U582**  
 Surface Mounted Sanitary Napkin  
 Disposal  
 Revision 03/11

JOB #:  
 ITEM #:  
 QUANTITY:

MOUNTING	HANDING	TYPE	SIZE	OTHER

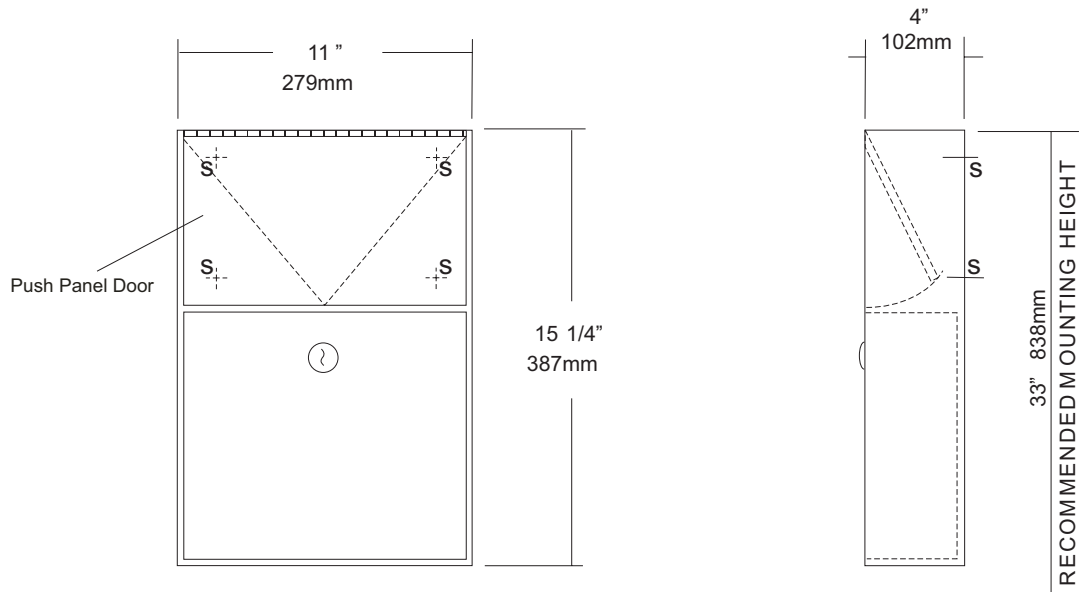

**SPECIFICATIONS**

**Cabinet Body:** Fabricated of #22 ga stainless steel #4 satin finish,  
**Push Panel:** Fabricated of #22 ga stainless steel self closing push panel. International graphic symbols are optional.  
**Waste:** #22 ga stainless steel removable type waste secured by a pin tumbler lock. Optional finger grip in lieu of lock is available.  
**Locks:** Pin tumbler commercial quality locks keyed like all other AJW cabinets,  
**Hinge:** Full length, heavy duty, stainless steel piano type hinge,  
**Overall Size:** 11"W x 15 1/4"H x 4"D  
**279mm x 387mm x 102mm**  
**Capacity:** 1.5 gallons (.2 cu ft.)  
**NDL-13-50:** Waxed disposable liners. (50 per Case)  
**OPTIONS:**  
 -PW: Rigid plastic waste insert  
 -IGS: International Graphic Symbol

**INSTALLATION**

Provide an area on wall surface at desired or specified location. Place unit on wall and verify unit is level. Transfer mounting point locations and drill pilot holes. Remove waste can and secure to wall surface with proper fasteners for each application.

**NOTES**

MOUNTING	HANDING	TYPE	SIZE	OTHER

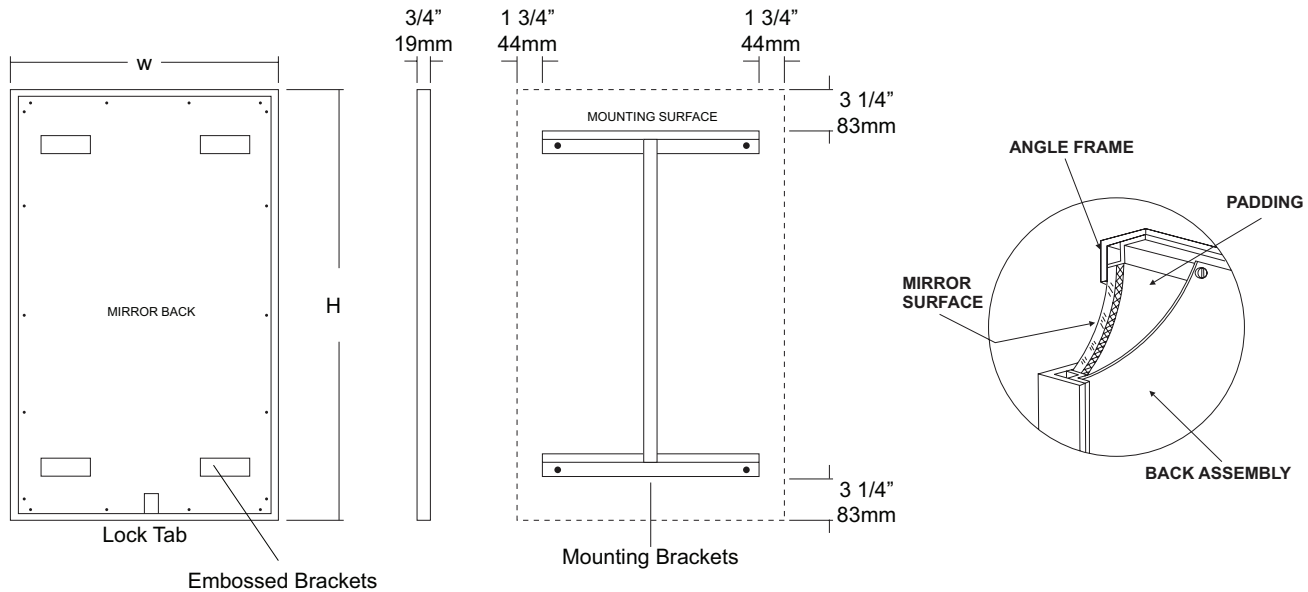

#### SPECIFICATIONS

**Frame:** Fabricated of #18 ga stainless steel, #4 satin finish. 3/4" x 3/4" frame with welded mitered corners are ground and polished smooth. #22 ga concealed "Z" channel is spot welded to inner perimeter of frame for reinforcement and greater rigidity.

**Mirror:** 1/4" thick type 1 transparent flat type, class 1 - clear glass mirrors. Mirror is coated with silver and sealed with a uniform electrolytic copper plating, along with two coats of paint for added protection. Mirrors are guaranteed against silver spoilage for a period of 15 years. Mirrors conform to ASTM C1036 and ASTM C1503-R8.

**Filler:** 3/16" thick full size, shock absorbing, water resistant, non-abrasive polyethylene padding protects all concealed mirror surfaces.

**Back:** #20 ga pre-plated galvanized steel, with embossed horizontal louver mounting brackets. Embossed theft resistant pressure activated clip lock device, locks mirror in place to wall hangers. Back is secured to frame with concealed Phillips head screws.

**Hangers:** Fabricated of #20 ga pre-plated steel galvanized steel with mounting points.

**Standard Sizes Available (W x H):** 16"x24", 16"x20", 16"x30", 18"x24", 18"x30", 18"x36", 20"x60", 24"x30", 24"x36", 24"x42", 24"x48", 18"x60", 24"x60", 24"x72", 18"x72"

#### Options:

- LG:** Laminated Glass
- LX:** Polycarbonate
- PM:** Plastic Acrylic
- T:** Tempered Glass
- VC:** Vinyl Clad (Safety Glass)
- 8B:** #8 Reflective Stainless Steel

\* Stainless steel mirrors reflect images in different optic quality than plate glass. There will be a slight distortion which increases proportionately with the mirror size. Therefore, AJW Architectural Products™ cannot be held responsible for quality of image.

\*\* Mirrors are always ordered Width x Height

\*\*\* Recommended max size for 8B mirrors: 72" x 47-1/2"

\*\*\*\* Framed mirrors are fabricated to a tolerance of (+/-) 1/8"

\*\*\*\*\* Mirrors conform to Federal Specifications DD-M-00411b & DDg-541D.

#### INSTALLATION

Coordinate installation with architect / contractor for specific mounting location and height for each mirror application. Making sure "I" bracket is level, transfer all mounting point locations to wall surface from drawing. Secure brackets with proper fasteners for each application. Slide mirror down over horizontal brackets until clip lock secures mirror in place. Mirror can only be removed by inserting tool through hole at bottom of frame depressing clip. This will allow mirror to slide up over brackets. Fillers are available if mirrors are mounted above and below tile line. (U004 Filler) filler material will match mirror frame to form a one piece construction.

To meet ADA Code, bottom edge of reflective surface can be no higher than 40" above finished floor. (4.19.6) Full length mirrors may be used for universal application when installed in correct locations.

Abrasive cleaners & chloric solutions should not be used on mirrors. Discoloring and /or scratching of frame and reflective surface may occur.

#### NOTES

# U700 Installation Instruction Sheet

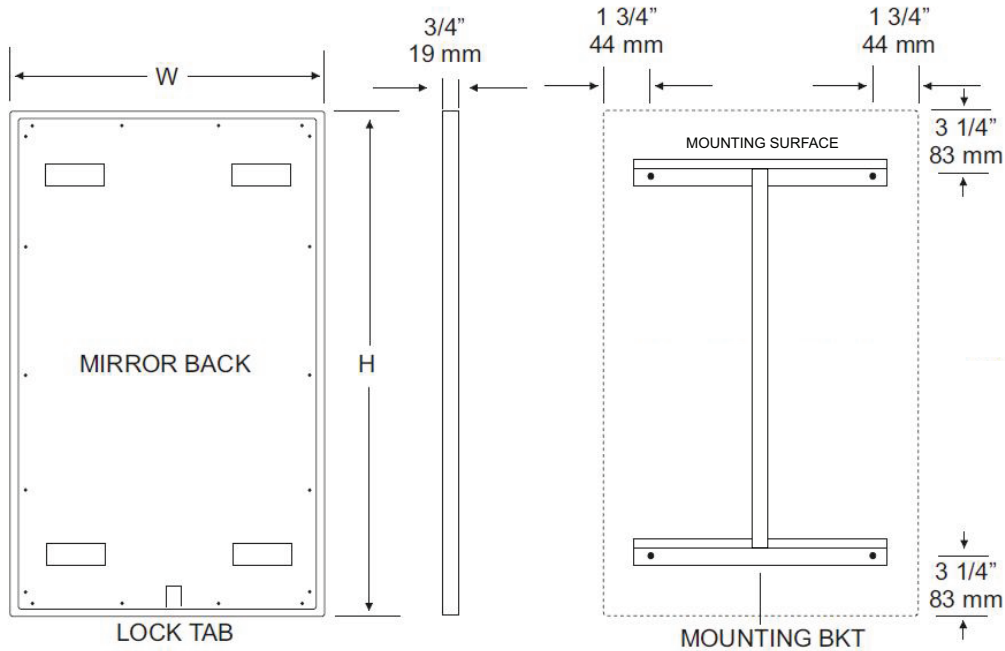

## INSTALLATION

Coordinate installation with architect / contractor for specific mounting location and height for each mirror application. Making sure "I" bracket is level, transfer all mounting point locations to wall surface from drawing. Secure brackets with proper fasteners for each application. Slide mirror down over horizontal brackets until clip lock secures mirror in place. Mirror can only be removed by inserting tool through hole at bottom of frame depressing clip. This will allow mirror to slide up over brackets. Fillers are available if mirrors are mounted above and below tile line. (U004 Filler) Filler material will match mirror frame to form a one piece construction.

To meet ADA Code, bottom edge of reflective surface can be no higher than 40" above finished floor. (4.19.6) Full length mirrors may be used for universal application when installed in correct locations.

## CARE & CLEANING

Wipe mirrors with a soft cloth, taking special care to rub stainless steel frames with the grain to avoid scratching. Do not use abrasive cleaners containing chloric solutions on stainless steel frames. Glass Plus or other window cleaning products are ideal.



**U778 Series**  
Surface Mounted Shelf

Revision 07/11

JOB #:

ITEM #:

QUANTITY:

MOUNTING	HANDING	TYPE	SIZE	OTHER

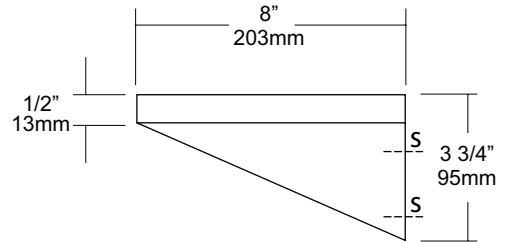
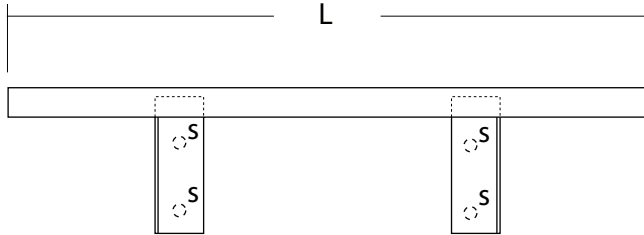

**SPECIFICATIONS** **INSTALLATION**

**Shelves:** Fabricated of #18 ga stainless steel. All edges are turned down 1/2" with front edges turned down & back 1/2" for maximum strength and rigidity. All corners are deburred and polished smooth for safety.

**Brackets:** Fabricated of #16 ga stainless steel permanently welded to shelf with exposed mounting points. Brackets are spaced maximum 30" centerline.

**Surface mounted shelf 8"D. (203mm)**

Provide an area on wall surface at desired or specified location. Place unit up to wall making sure unit is level. Transfer mounting points to surface and drill pilot holes. Secure shelf to surface with proper fasteners per each application.

**NOTES**



# U812

Toilet Tissue Dispenser

Revision 03/11

JOB #:

ITEM #:

QUANTITY:

MOUNTING	HANDING	TYPE	SIZE	OTHER

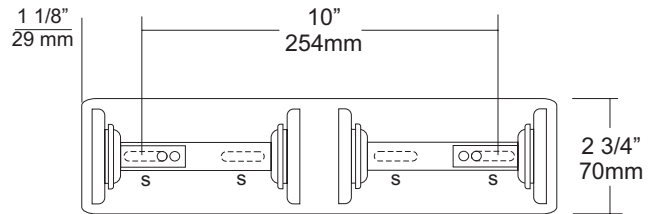
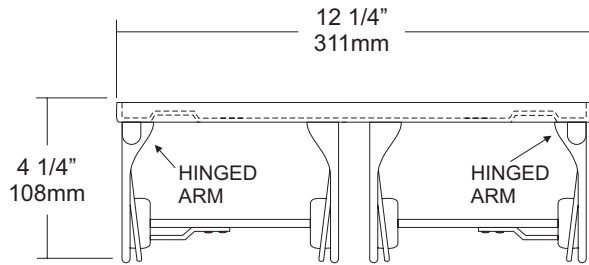

### SPECIFICATIONS

**Mounting Plate:** Bright chrome plated #22 ga steel formed for maximum strength.

**Arms:** Hinged arms (one for each roll) are #22 ga bright chrome plated. The other arm is fixed. Both arms are fabricated with an extended support to maintain toilet tissue roll. This is a controlled type dispensing system.

**Overall Size:** 12 1/4"W x 2 3/4"H x 4 1/4"D

**311mm x 70mm x 108mm**

**Capacity:** Two standard rolls with a 5 1/4" (133mm) OD.

### INSTALLATION

Provide an area on wall surface at desired or specified location. Hold unit to surface and make sure unit is level. Transfer mounting points to wall and drill pilot holes. Secure units with proper fasteners per application. Open units by depressing tab on spindle that allows arm to unlock. Load tissue on spindle and snap close.

**Toilet Paper Dispensers:** All dispensers that are to meet ADA code cannot have any type of controlled delivery. (4.16)

### NOTES





# U939

## Retractable Shower Bench

Revision 12/14

JOB #:

ITEM #:

QUANTITY:

MOUNTING	HANDING	TYPE	SIZE	OTHER

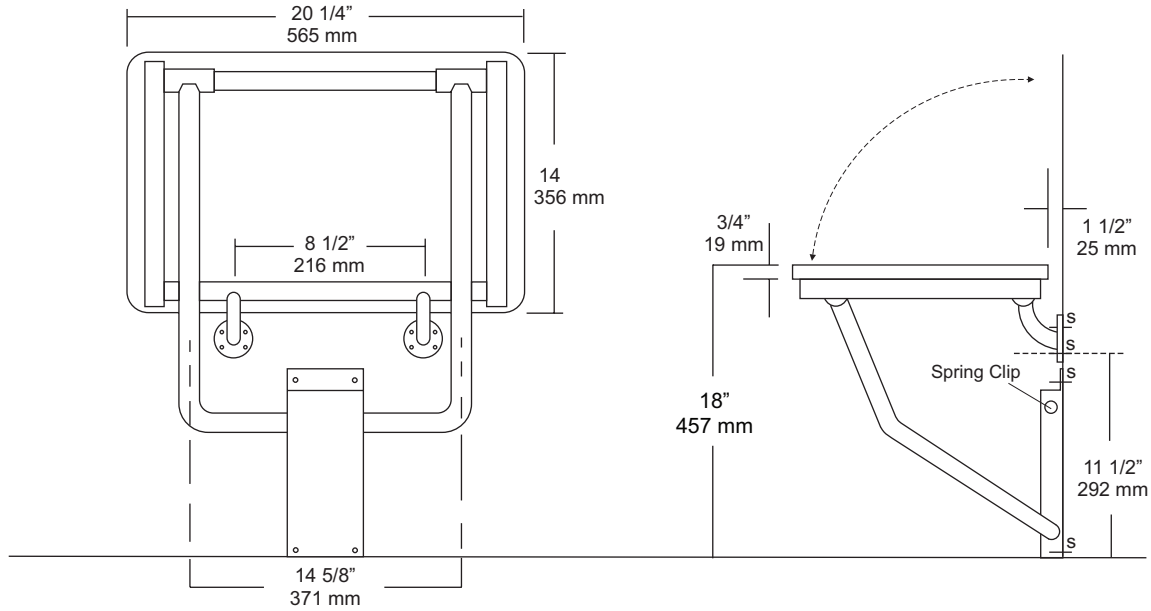

### SPECIFICATIONS

**Seat:** Fabricated of 3/4" thick, one piece polymers (white) with all leading edges having a radius to prevent injury. Seat is secured to frame with carriage bolts and acorn nuts.

**Tubing:** Fabricated of #18 ga stainless steel with #4 satin finish.

**Main Frame:** 1 1/4" diameter square tubing with capped ends.

**Flanges:** #18 gauge stainless steel with four (4) countersunk exposed mounting points. Under slung supports have a 1 1/4" OD. (Satin finish)

**Mounting Bracket:** #14 ga stainless steel "hat" style bracket with 4 mounting support points. Bracket acts as a guide to raise and lower seat platform and is equipped with four (4) points to secure to wall surface. For maximum support, bracket is mounted so the bottom is set on the finished floor surface. Seat will remain in an upright position when not in use by means of a spring clip.

**Overall Size:** 20 1/4"W x 14"D (seating area)

**514mm x 356mm**

**\*Wall to floor mounting design provides equal distribution of weight to ensure safe operation.**

### INSTALLATION

To comply with ADA Code, seat should be mounted at a height 17"-19" above finished floor. Check all state and local codes for building requirements. Recommend in wall mounting on all shower seats. (BP10) Place seat up against wall making sure the extended part of seat has an offset no more than 1 1/2" away from wall. (Same as grab bar) Transfer mounting points to wall surface and drill pilot holes. Secure seat to surface with proper fasteners per each application. Snugly secure seat to surface and check seat to be level. If seat is level raise and lower seat to check path of travel. Finish securing seat after checking seat for proper operation. When properly mounted seat will support up to 250 lbs and will conform with ADA Code 4.21.3 and 4.26.3

Note: This shower seat is not intended to be installed in applications that have shower bases with rounded corners. AJW recommends the U928 for such applications.

### NOTES

Formerly Model #: U939-1A

# U939 Mounting Instructions

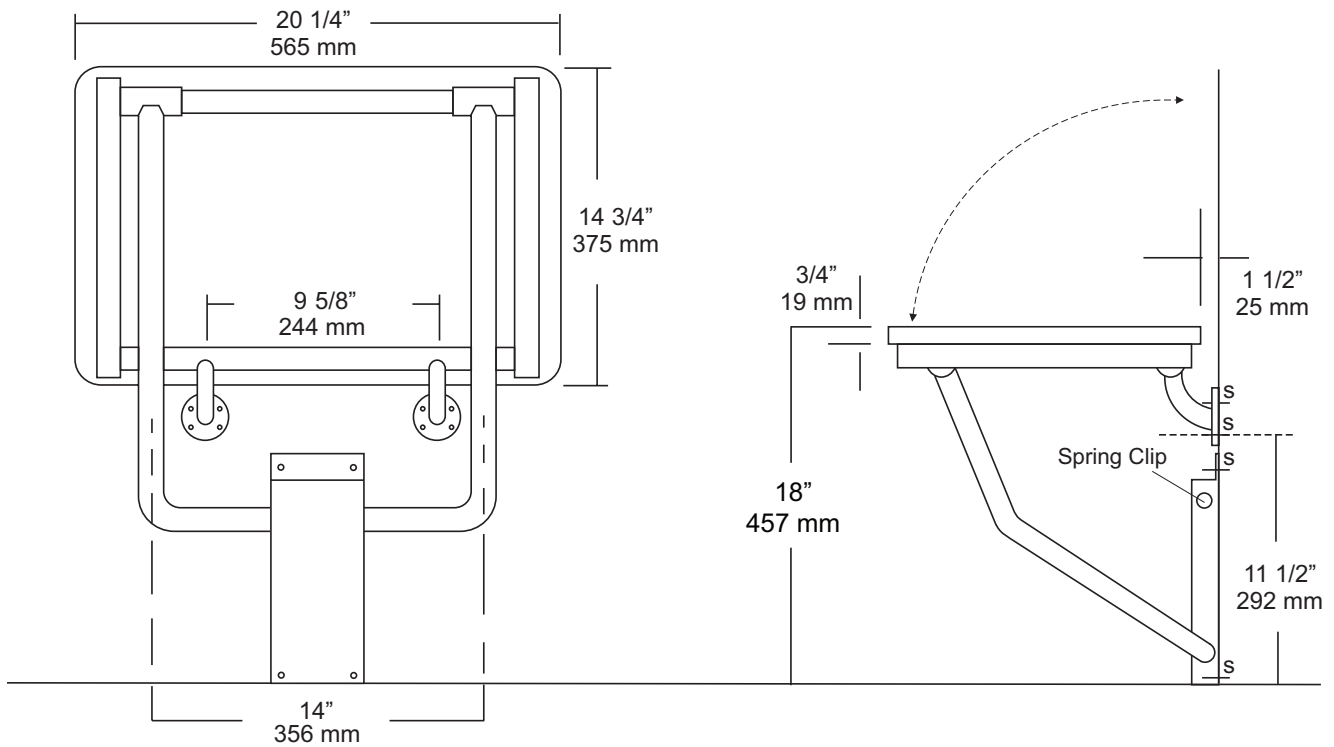

## INSTRUCTIONS

1. Seating area of shower seat should be mounted at a height of 17" – 19" above finished floor (check local codes for any variances).
2. Concealed in wall mounting plates (BP10) must be used to ensure maximum support for seat. AJW recommends that mounting fasteners be at least 2 1/2" in length (depending on wall depth).
3. Plastic shields should not be used when securing shower seat



# UC12

Double Robe Hook

Revision 03/11

JOB #:

ITEM #:

QUANTITY:

MOUNTING	HANDING	TYPE	SIZE	OTHER

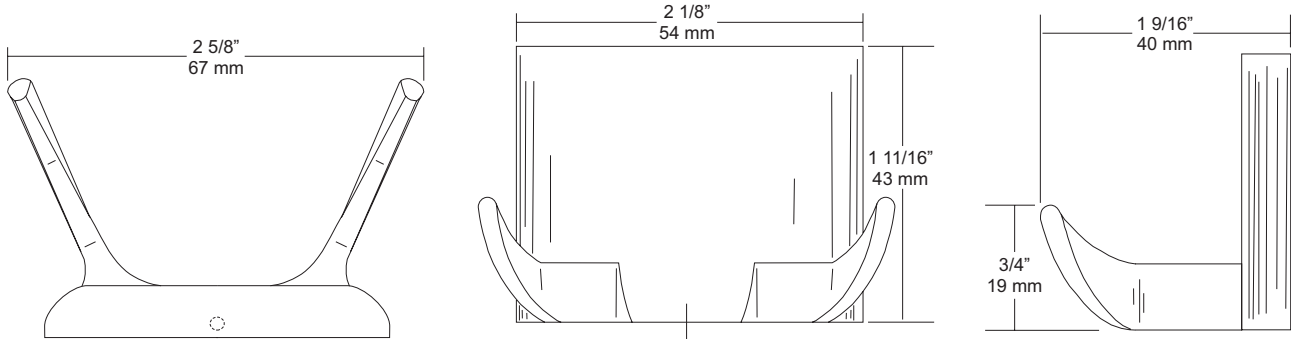

### SPECIFICATIONS

**UC Accessories:** All accessories are fabricated of high polished chrome plating over virgin zinc die cast. All UC items comply with standard federal specifications.

**Overall Size:** 2 5/8"W x 1 11/16"H x 2 9/16"D  
67mm x 44mm x 40mm

### INSTALLATION

Place concealed mounting bracket on wall surface at desired location. Transfer mounting points and drill pilot holes. Secure plate with proper fasteners per application. Place item over plate making sure it fits snugly and secure on the underside with supplied set screw.

### NOTES



# UG2-A

Grab Bars

Revised 03/11

JOB #:

ITEM #:

QUANTITY:

MOUNTING	HANDING	TYPE	SIZE	OTHER

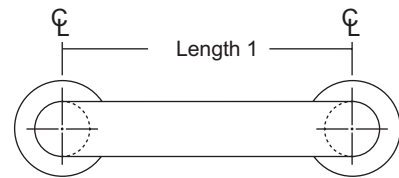
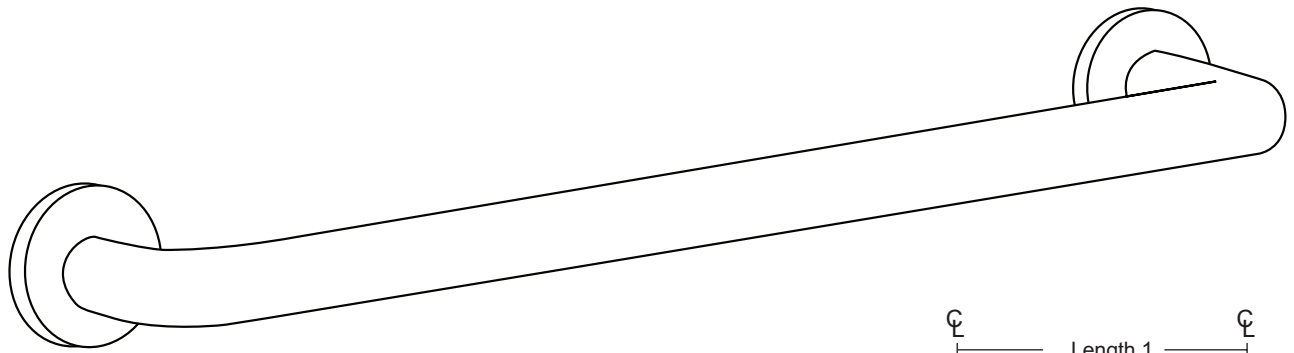

### SPECIFICATIONS & INSTALLATION

**Tubing:** Fabricated of #18 ga stainless steel with a #4 satin finish. Available in 1 1/4" outside diameter. All bends are formed by an automatic mandrel bending process. All bars maintain a constant 1 1/2" offset.

**Finish:** Standard finish is a #4 satin finish. For a non-slip finish (peened) add suffix X to model number. (Ex. UG2X-A)

**Flanges:** Snap flanges are fabricated of 3" diameter, 3/8" deep drawn #22 ga stainless steel with #4 satin finish to match tubing. Flanges have dimples that secure over mounting plate.

**Strength:** Bars with a 1 1/2" offset clearance will support loads in excess of 900lbs when properly installed. Bars with greater offsets will support loads up to 250lbs when properly installed.

**Installation:** Before installing grab bars, verify with all state and local codes for requirements on bar diameter and type finish. Recommended mounting heights for grab bars are 33" - 36" centerline above finished floor. All mounting of grab bars when possible should have in wall mounting back plates. Find centerline mounting points and place bar on line making sure to be on center. Transfer mounting points (3 per flange) to wall. Drill pilot holes and secure bar with proper anchors per application. Snap cover over mounting plate.

**Standard Lengths (Other sizes available upon request):** 12", 16", 18", 24", 30", 32", 36", 42", 48", 50", 52", 54", 56"

### FLANGE INFORMATION

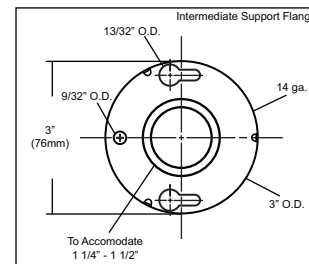
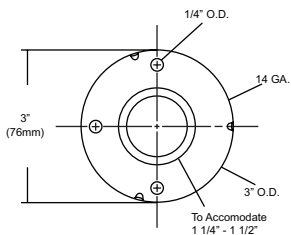
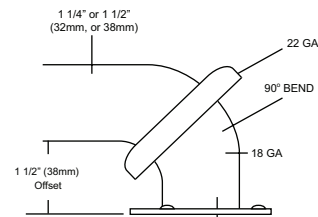

### NOTES



# UJ14 Series Hook Strip

Revision 03/11

JOB #:

ITEM #:

QUANTITY:

MOUNTING	HANDING	TYPE	SIZE	OTHER

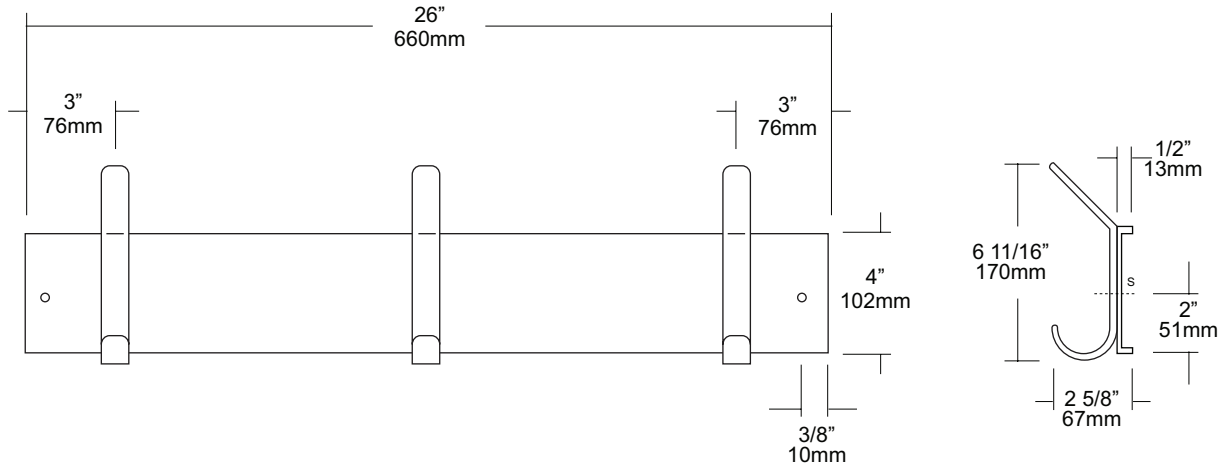

### SPECIFICATIONS

**Hook Strip:** Fabricated of #20 ga stainless steel with a #4 satin finish. Ends of strip are returned 1/2" to wall surface.

**Hooks:** Fabricated of #14 gauge stainless steel finished to match strip. Leading edges of hooks are radiused to prevent injury and extends 2 5/8" from strip surface.

**Verify Style:**

- UJ14A:** 26"L (660mm) with 3 hooks.
- UJ14B:** 36"L (914mm) with 4 hooks.
- UJ14C:** 46"L (1168mm) with 5 hooks.
- UJ14D:** 56"L (1422mm) with 6 hooks.

### INSTALLATION

Place unit to wall surface making sure unit is level and transfer mounting points. Drill pilot holes and secure unit with proper fasteners per application.

### NOTES

## UX132-BF Series Round Towel Bar

Revision 03/11

JOB #:

ITEM #:

QUANTITY:

MOUNTING	HANDING	TYPE	SIZE	OTHER

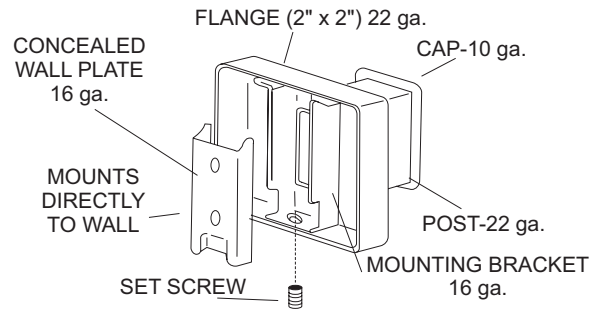
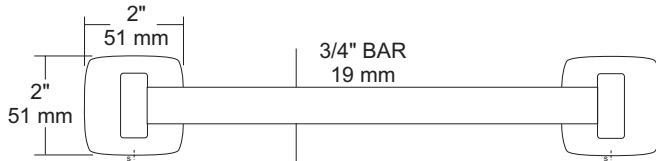
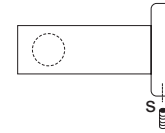
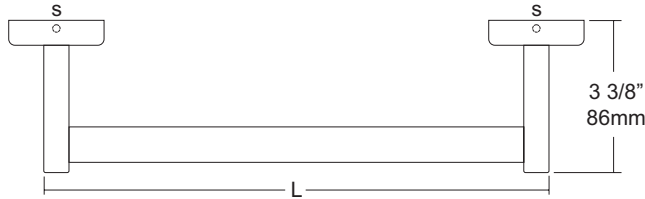

### SPECIFICATIONS

**UX Accessories:** All UX bath accessories series are fabricated of stainless steel with a bright or satin finish. Mounting plates are concealed with a snap-on type plate secured by a set screw.

**Flange:** 2" x 2" flange #22 ga stainless steel.

**Post:** #22 ga stainless steel.

**Bar:** #22 ga stainless steel, 3/4" dia

**Mounting Plate:** #16 ga concealed wall plate. Set screw secures mounting plate and flange.

**Overall Size:** 2"H x 3 3/8"D (51mm x 86mm)

**Standard Lengths:** 18", 24", 30", 36" (475mm, 610mm, 762mm, 914mm)

**UX132-SF:** Same as UX132-BF with satin finish.

### INSTALLATION

Provide an area on wall surface at desired or specified location. The centerline distance between the mounting plates is 1/2" less than the length of the towel bar. Place concealed mounting plate on wall surface and transfer mounting plate on wall surface and transfer mounting points. Drill pilot holes and secure with proper fasteners. Place snap-on flange over plate and secure with set screw. Repeat same step for second post. Place towel bar in post and place cover over plate to make sure spread is correct. Secure cover if bar fits.

### NOTES



**UX169**  
Shower Curtain Hooks

Revision 03/11

JOB #:

ITEM #:

QUANTITY:

MOUNTING	HANDING	TYPE	SIZE	OTHER

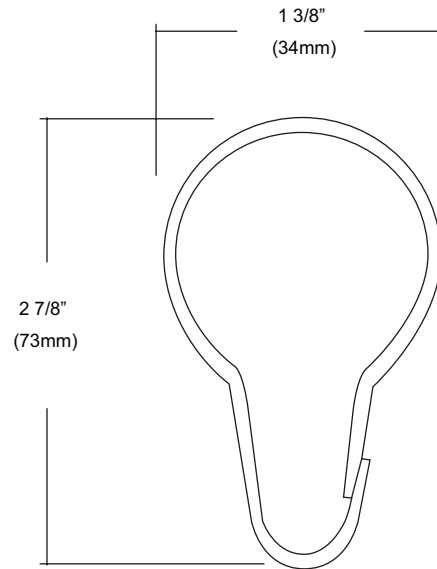

**SPECIFICATIONS**

Unit is constructed of stainless steel. Ring snaps around the shower rod to support curtain. Spacing of hooks is every 6" and can be installed on both 1" & 1 1/4" diameter rods.

Overall Size: 1 3/8"W x 2 7/8

34mm x 73mm

**INSTALLATION**

Thread hook through curtain eyelet. Slide rings onto curtain rod. Hook can accommodate 1" & 1 1/4" rods.

**NOTES**

# UX250P Vinyl Shower Curtain

## Installation & Cleaning Instructions

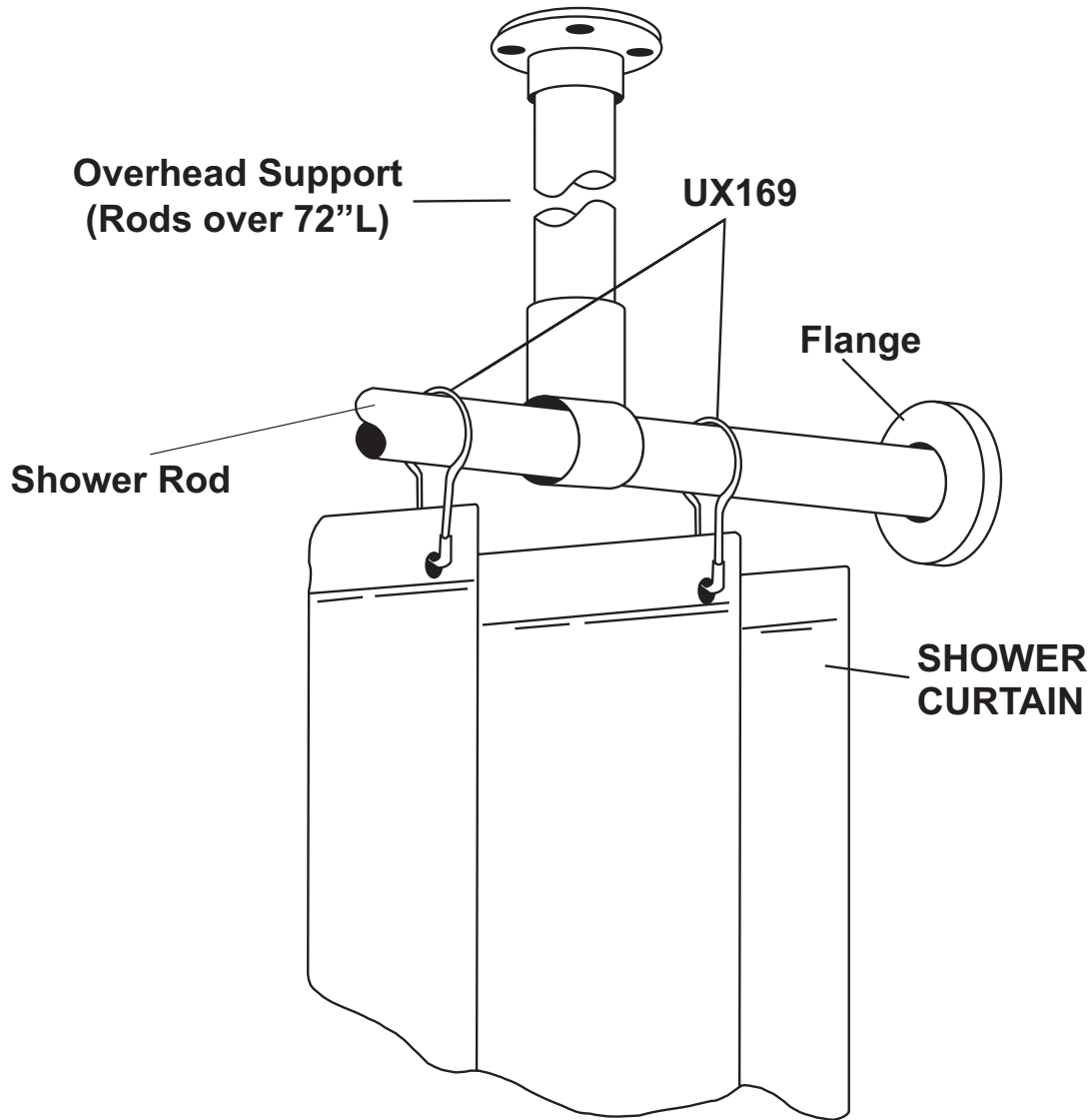

### INSTALLATION

**Recommended:** UX169 stainless steel shower curtain hooks to connect to AJW shower curtain rods. Various types of flanges are available to secure rod and curtain to mounting surface (exposed and concealed).

**Measuring Curtains:** Curtains are measured W x H. The same curtain will fit a 1 or 1 1/4" diameter rod.

### CARE & CLEANING

Machine wash cold water (not exceeding 41°C / 105°F). Do not bleach. Do not dry clean. Tumble dry low ( not exceeding 140°F). Remove promptly.



JOB #:

ITEM #:

QUANTITY:

MOUNTING	HANDING	TYPE	SIZE	OTHER

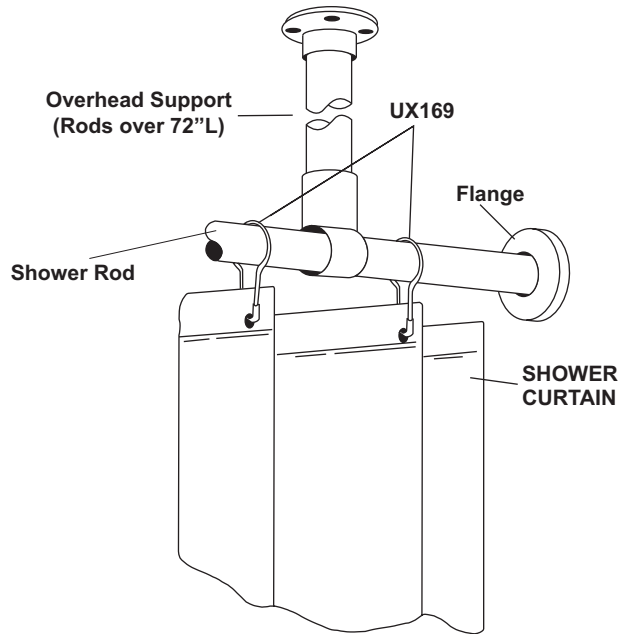

SPECIFICATIONS	INSTALLATION
----------------	--------------

**Bacteria & Mildew Resistant:** Heavy duty vinyl film (8 mil) that is flame retardant, durable and waterproof. Microbiotic KV-33 is an integral part added to the fabrication of this curtain that can be laundered repeatedly without losing this barrier against bacteria, fungus and mildew. KV-33 is a durable bacteriostat, mildewstat and fungistat that will provide protection for as long as you use this style curtain. It will retard the growth of organisms, thereby inhibiting odors caused by decaying bacteria.

**Design:** To insure the ultimate in bacteria free curtain, there are no side hems to hinder the flow-off of soap and water. This also makes cleaning easier. The heading is reinforced with a ten gauge vinyl film with rust proof anodized eyelets spaced 6" apart.

**Cleaning:** Sponge with warm mild soap and rinse with clear water.

**Machine washing:** Relatively cool water temp not to exceed 120 degrees F. DO NOT USE DETERGENTS. Air dry at low temp. Colors: Standard stock color is white. Special order for other colors are available on request.

**\*UX1-V/UX2-V:** Overhead s/s supports for oversized shower rods. (For shower rods over 72" in length an overhead support is recommended)

**UX1-V:** 1" OD shower rods.

**UX2-V:** 1 1/4" OD shower rods.

Recommended: UX169 stainless steel shower curtain hooks to connect to AJW shower curtain rods. Various types of flanges are available to secure rod and curtain to mounting surface (exposed and concealed).

Measuring Curtains: Curtains are measured W x H. The same curtain will fit a 1 or 1 1/4" diameter rod.

**NOTES**

Formerly Model #: 250P



# UX61-BF

Soap Dish

Revision 03/11

JOB #:

ITEM #:

QUANTITY:

MOUNTING	HANDING	TYPE	SIZE	OTHER

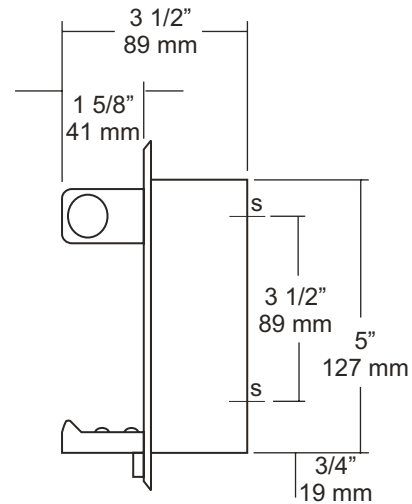
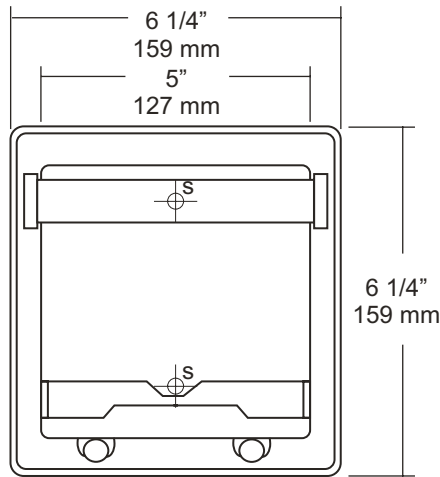

### SPECIFICATIONS

**Shell:** Drawn one piece construction fabricated of #22 gauge stainless steel with a bright finish. Two mounting points allow unit to be secured to mounting clamps or framing in wall opening.

**Soap Holder:** Fabricated of high impact clear ABS material that snaps in place on two exposed pins on the front face of the unit.

**Bar Supports:** Fabricated of heavy duty cast Zamac with a bright chrome finish with a 3/4" OD stainless steel bar to support wash cloths.

**Bar is not designed to support a person's weight.**

**Overall Size:** 6 1/4"W x 6 1/4"H x 3 1/2"D

**165mm x 165mm x 89mm**

**Wall Opening:** 5 1/4"W x 5 1/4"H x 2"D

**133mm x 133mm x 51mm**

### INSTALLATION

Provide a wall opening at desired or specified area and coordinate with contractor or architect to avoid interference with pipes, vents, etc. Secure unit in wall opening with proper fasteners and/or clamps required per each application.

Mounting Clamps:

"A" Clamp: Applicable where backing or framing is not available. Used on existing walls.

"B" Clamp: Conventional type clamp, secured to back side of front wall.

### NOTES