

date
projectname
attn
from
fax
email
phone

10/18/2016
E.Henry Twiggs
Tina Gonzalez
Tina Gonzalez
4137889689
tpolley@bsahinc.com
4137889686

JOB #:

ITEM #:

QUANTITY:

| MOUNTING | HANDING | TYPE | SIZE | OTHER |
|----------|---------|------|------|-------|
| | | | | |

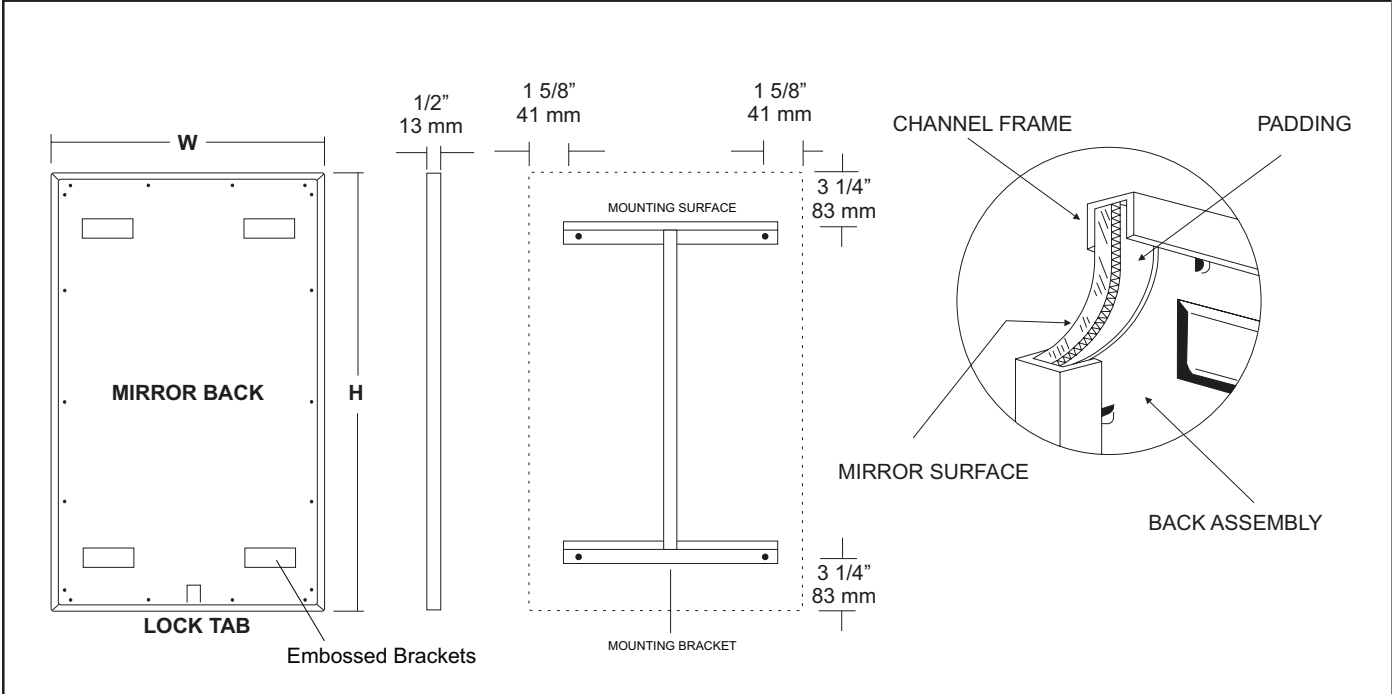

SPECIFICATIONS

Frame: Fabricated of #20 ga stainless steel, #4 satin finish. Roll formed 1/2" x 1/2" x 1/2" channel frame has mitered corners and secured with stainless steel rivet.

Mirror: 1/4" thick type 1 transparent flat type, class 1 - clear glass mirrors. Mirror is coated with silver and sealed with a uniform electrolytic copper plating, along with two coats of paint for added protection. Mirrors are guaranteed against silver spoilage for a period of 15 years. Mirrors conform to ASTM C1036 and ASTM C1503-R8.

Filler: Full size, 1/8" shock absorbing, water resistant, nonabrasive, polyethylene padding protects all concealed mirror surfaces.

Back: #20 ga pre-plated galvanized steel, with embossed horizontal louver mounting brackets. Embossed theft resistant pressure activated clip lock device, locks mirror in place to wall hangers.

Hangers: Fabricated of #20 ga pre-plated steel galvanized steel with mounting points.

Standard Sizes Available (W x H): 16"x20", 16"x24", 16"x30", 18"x24", 18"x30", 18"x36", 24"x30", 24"x36", 24"x42", 24"x48", 18"x60", 20"x60", 24"x60", 18"x72", 24"x72"

Options:

- LG:** Laminated Glass
- LX:** Polycarbonate
- PM:** Plastic Acrylic
- T:** Tempered Glass
- VC:** Vinyl Clad (Safety Glass)
- 8B:** #8 Reflective Stainless Steel

*Stainless steel mirrors reflect images in different optic quality than plate glass. There will be a slight distortion which increases proportionately with the mirror size. Therefore, AJW Architectural Products™ cannot be held responsible for quality of image.

- **Mirrors are always ordered Width x Height
- ***Recommended max size for 8B mirrors: 72" x 47-1/2"
- ****Framed mirrors are fabricated to a tolerance of (+/-) 1/8"
- ***** Mirrors conform to Federal Specifications DD-M-00411b & DD-g-541D

INSTALLATION

Coordinate installation with architect / contractor for specific mounting location and height for each mirror application. Making sure "I" bracket is level, transfer all mounting point locations to wall surface from drawing. Secure brackets with proper fasteners for each application. Slide mirror down over horizontal brackets until clip lock secures mirror in place. Mirror can only be removed by inserting tool through hole at bottom of frame depressing clip. This will allow mirror to slide up over brackets. Fillers are available if mirrors are mounted above and below tile line. (U004 Filler) filler material will match mirror frame to form a one piece construction.

To meet ADA Code, bottom edge of reflective surface can be no higher than 40" above finished floor. (4.19.6) Full length mirrors may be used for universal application when installed in correct locations.

Abrasive cleaners & chloric solutions should not be used on mirrors. Discoloring and /or scratching of frame and reflective surface may occur.

NOTES

| MOUNTING | HANDING | TYPE | SIZE | OTHER |
|----------|---------|------|------|-------|
|----------|---------|------|------|-------|

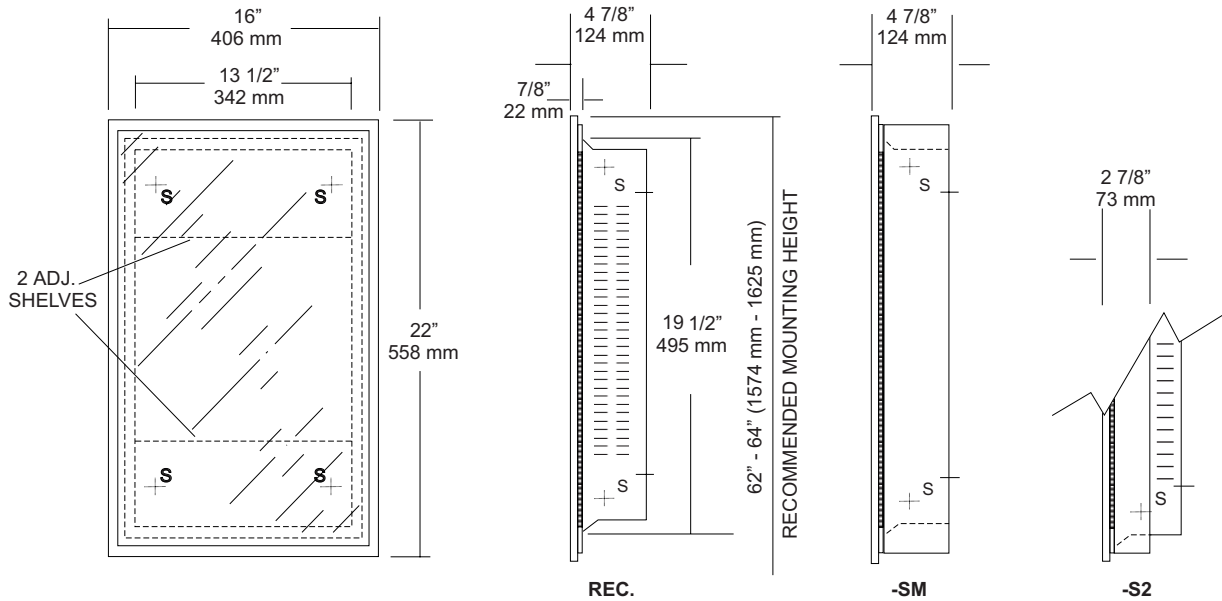

SPECIFICATIONS

Cabinet Body: Fabricated of #22 ga stainless steel formed for rigidity. Embossed louvers in body allow shelving to be adjustable. Flange surrounds cabinet body that has 1/4" returns to wall. (No miters or welds)

Cabinet Back: Stainless steel secured to cabinet body with multiple welds to cabinet body.

Mirror Door: 1/4" thick float plate glass, silver coated and sealed with a uniform coating of electrolytic copper plating. Mirror is guaranteed against silver spoilage for a period of 15 years. Non-absorbent filler behind mirror acts as a shock absorber.

Channel Frame: #22 ga stainless steel #4 satin finish.

Adjustable Shelving: Two (2) #22 ga stainless steel with #4 satin

Catch: Heavy duty magnetic catch.

Hinges: Full length, heavy duty stainless steel piano type

Collars: #22 ga stainless steel with #4 satin, one piece construction, finished to match cabinet body.

Overall Size: 16"W x 22"H x 4 7/8"D
406mm x 558mm x 124mm

Wall Opening: 14"W x 20"H x 4"D
355mm x 508mm x 102mm

U720-1622-S2: 2" Semi-Recessing collar, 2" wall opening

U720-1622-SM: Fully surface mounted collar

INSTALLATION

Coordinate installation with architect and contractor. Provide a wall opening 14"W x 20"H. Depth will depend on style mounting. Insert cabinet into opening making sure cabinet is level and door will remain open until you manually close it. Secure cabinet with proper fasteners per application. Unit can be mounted to have a right hand or left hand swing door. Collars can be added in the field to accommodate semi-recessing or full surface mounting.

To comply with ADA code, one usable shelf must be mounted no higher than 44" above finished floor. (4.2.4)

NOTES

Formerly Model #: U721-1622



U936 Retractable Tub Seat

Revision 10/14

JOB #:

ITEM #:

QUANTITY:

| MOUNTING | HANDING | TYPE | SIZE | OTHER |
|----------|---------|------|------|-------|
| | | | | |

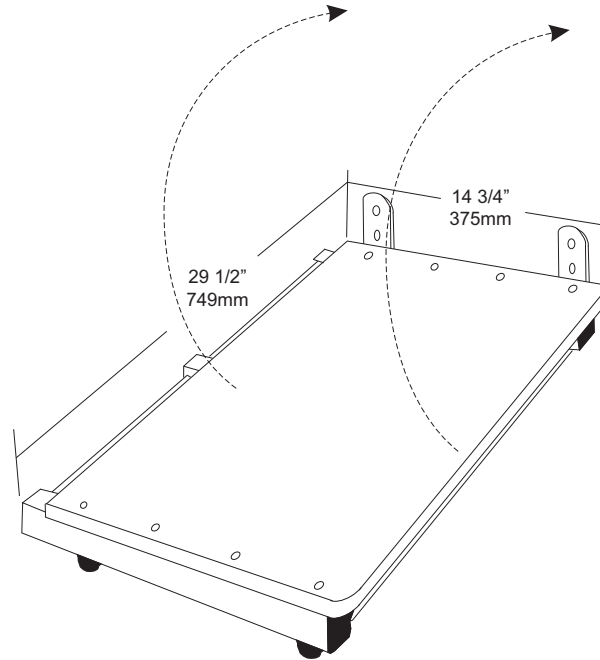

SPECIFICATIONS

Seat: Fabricated of 3/4" solid one piece, white HDP (High Density Plastic) with radius leading edges to prevent injury. Secured to frame by means of 1/4" stainless steel rivets. Seat material is warp / water resistant and will not support bacteria or fungi. There are no chemicals that may irritate human skin.

Frame: Fabricated of #18 gauge 1 1/4" stainless steel square tubing, #4 satin finish with capped ends. No exposed fasteners. 1" diameter stainless steel tubing (same material) cross tubing provides added strength and rigidity.

Mounting Supports: Square tubing (#18 ga) along with #11 gauge vertical mounting plated with exposed mounting points.

Anti Slip Supports: Frame is equipped with anti slip/ anti scratching devices.

Overall Size: 29 1/2"W x 14 3/4"D

749mm x 375mm

Seating Area: 28 1/2"W x 12 7/8"D

724mm x 327mm

INSTALLATION

Place tub seat on rim of tub. Make sure seat is square with corner of the tub area. Transfer mounting points to wall surface. Drill pilot holes for mounting. Secure tub seat with proper fasteners per application. When ever possible use concealed in wall backing (BP10 plates) added support.

When seat is not in use in the upright position, seat will pass the 90 degree point and rest against wall. When mounted properly space between seat and wall will be no greater than 1 1/2".

NOTES



UG1 Grab Bars

Job #:

Item #:

Quantity:

| MOUNTING | HANDING | TYPE | SIZE | OTHER |
|----------|---------|------|------|-------|
| | | | | |

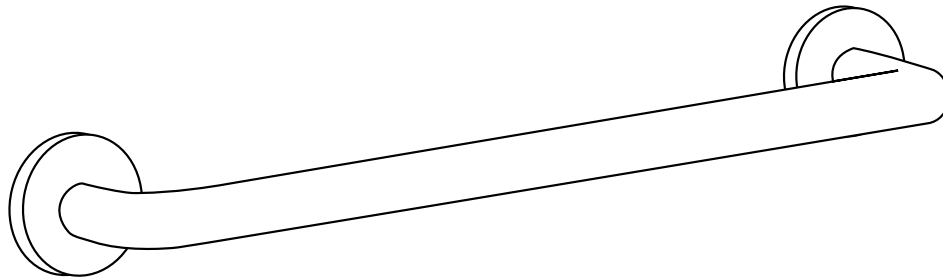

SPECIFICATIONS & INSTALLATION

Tubing: Fabricated of type 304 #18 ga stainless steel with a #4 satin finish. Available in 1" outside diameter. All bends are formed by an automatic mandrel bending process. All bars maintain a constant 1 1/2" offset.

Finish: Standard finish is a #4 satin finish. For a non-slip finish (peened) add suffix X to model number. (Ex. UG2X-A)

Flanges: Snap flanges are fabricated of 3" diameter, 3/8" deep drawn type 304 #22 ga stainless steel with #4 satin finish to match tubing. Flanges have dimples that secure over mounting plate.

Strength: Bars with a projection no more than 5" off finished wall will sustain loads in excess of 900 lbs. When properly mounted. Bars with more than 5" projection will sustain a load of 250 lbs for 5 minutes when properly mounted.

Installation: Before installing grab bars, verify with all state and local codes for requirements on bar diameter and type finish. Recommended mounting heights for grab bars are 33" - 36" centerline above finished floor. All mounting of grab bars when possible should have in wall mounting back plates. Find centerline mounting points and place bar on line making sure to be on center. Transfer mounting points (3 per flange) to wall. Drill pilot holes and secure bar with proper anchors per application. Snap cover over mounting plate.

FLANGE INFORMATION

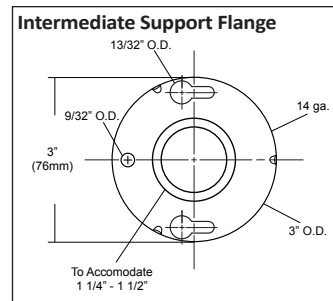
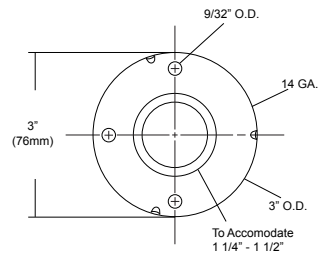
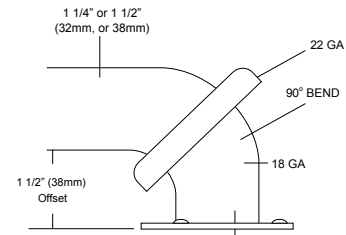



UG2-A

Grab Bars

Revised 03/11

JOB #:

ITEM #:

QUANTITY:

| MOUNTING | HANDING | TYPE | SIZE | OTHER |
|----------|---------|------|------|-------|
| | | | | |



SPECIFICATIONS & INSTALLATION

Tubing: Fabricated of #18 ga stainless steel with a #4 satin finish. Available in 1 1/4" outside diameter. All bends are formed by an automatic mandrel bending process. All bars maintain a constant 1 1/2" offset.

Finish: Standard finish is a #4 satin finish. For a non-slip finish (peened) add suffix X to model number. (Ex. UG2X-A)

Flanges: Snap flanges are fabricated of 3" diameter, 3/8" deep drawn #22 ga stainless steel with #4 satin finish to match tubing. Flanges have dimples that secure over mounting plate.

Strength: Bars with a 1 1/2" offset clearance will support loads in excess of 900lbs when properly installed. Bars with greater offsets will support loads up to 250lbs when properly installed.

Installation: Before installing grab bars, verify with all state and local codes for requirements on bar diameter and type finish. Recommended mounting heights for grab bars are 33" - 36" centerline above finished floor. All mounting of grab bars when possible should have in wall mounting back plates. Find centerline mounting points and place bar on line making sure to be on center. Transfer mounting points (3 per flange) to wall. Drill pilot holes and secure bar with proper anchors per application. Snap cover over mounting plate.

Standard Lengths (Other sizes available upon request): 12", 16", 18", 24", 30", 32", 36", 42", 48", 50", 52", 54", 56"

FLANGE INFORMATION

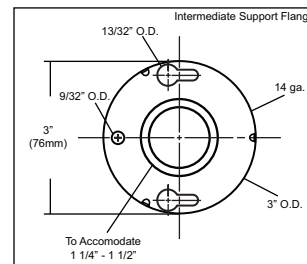
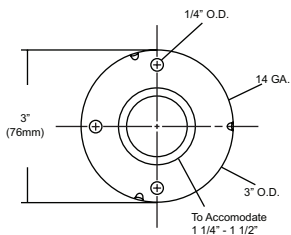

NOTES



UX112-BF

Double Robe Hook

Revision 12/11

JOB #:

ITEM #:

QUANTITY:

| MOUNTING | HANDING | TYPE | SIZE | OTHER |
|----------|---------|------|------|-------|
| | | | | |

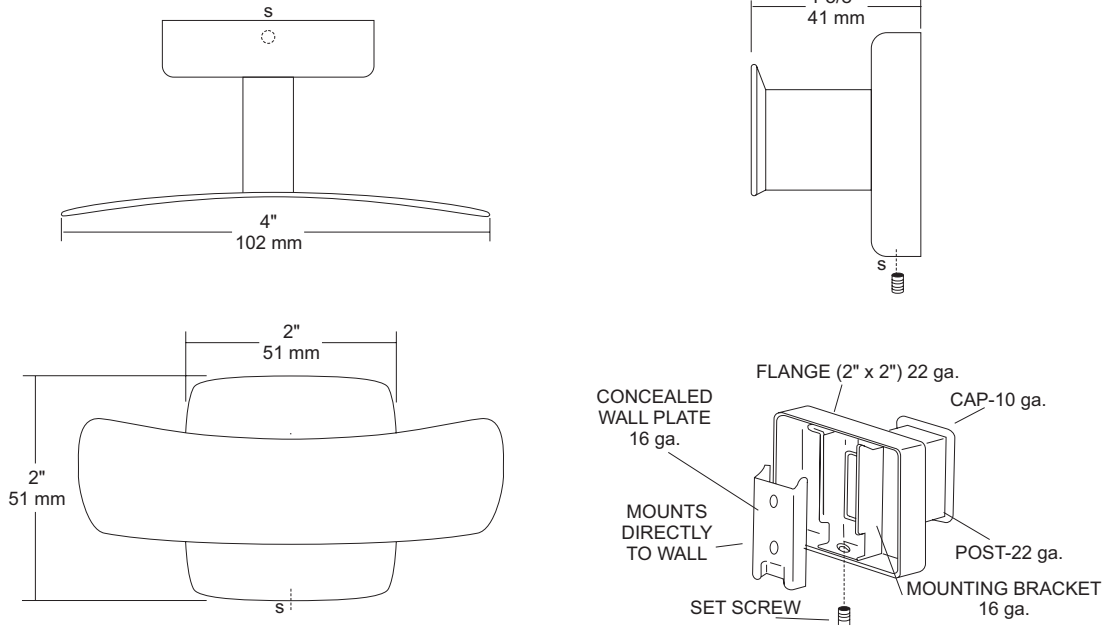

SPECIFICATIONS

UX Accessories: All UX bath accessories series are fabricated of stainless steel with a bright or satin finish. Mounting plates are concealed with a snap-on type plate secured by a set screw.

Hook: #10 ga stainless steel hook

Flange: 2" x 2" flange #22 ga stainless steel.

Post: #22 ga stainless steel.

Mounting Plate: #16 ga stainless steel concealed wall plate. Set screw secures mounting plate and flange.

Overall Size: 4"W x 2"H x 1 5/8"D

51mm x 51mm x 41mm

UX112-SF: Same as UX112-BF with satin finish.

INSTALLATION

Provide an area on wall surface at desired or specified location. Place concealed mounting plate on wall surface and transfer mounting points. Drill pilot holes and secure with proper fasteners. Place snap on flange over plate and secure with set screw.

NOTES

| MOUNTING | HANDING | TYPE | SIZE | OTHER |
|----------|---------|------|------|-------|
| | | | | |

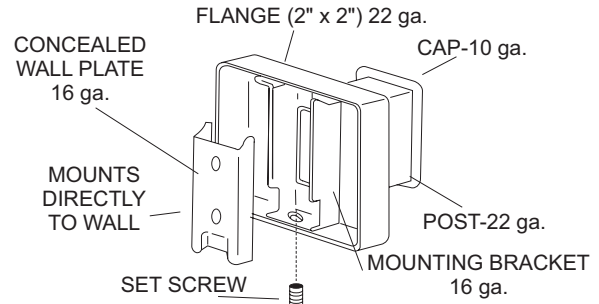
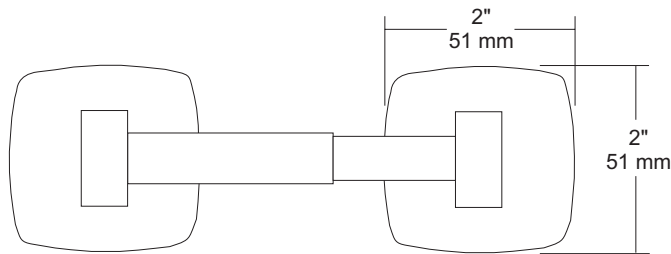
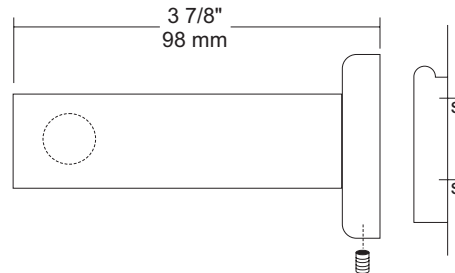
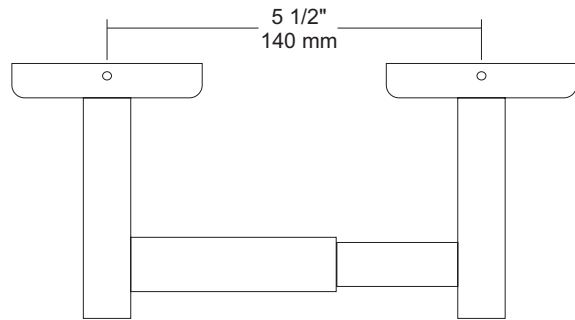

SPECIFICATIONS

UX Accessories: All UX bath accessories series are fabricated of stainless steel with a bright or satin finish. Mounting plates are concealed with a snap-on type plate secured by a set screw.

Flange: 2" x 2" flange #22 ga stainless steel.

Post: #22 ga stainless steel.

Mounting Plate: #16 ga concealed wall plate. Set screw secures mounting plate and flange.

Spindle: Spring loaded, chrome plated plastic.

Optional U007 Theft Resistant Adapter: Prevents spindle from being removed until roll has been depleted.

Overall Size: 7 1/2" W x 2"H x 1 5/8"D

51mm x 51mm x 43mm

UX141-SF: Same as UX141-BF with satin finish

INSTALLATION

Provide an area on wall surface at desired or specified location. Place concealed mounting plate on wall surface and transfer mounting points. Drill pilot holes and secure with proper fasteners. Place snap-on flange over plate and secure with set screw. Centerline space between posts is aprx. 5 1/2"W. Repeat same steps for other post. Place a roll of tissue on spindle and place in posts before securing the covers down securely. If roll spins freely, secure post with set screw. All toilet tissue dispensers must have a non-control delivery to meet ADA code. (4.16)

NOTES



UX2K
Flange & Shower Rod

Revision 03/11

JOB #:

ITEM #:

QUANTITY:

| MOUNTING | HANDING | TYPE | SIZE | OTHER |
|----------|---------|------|------|-------|
| | | | | |

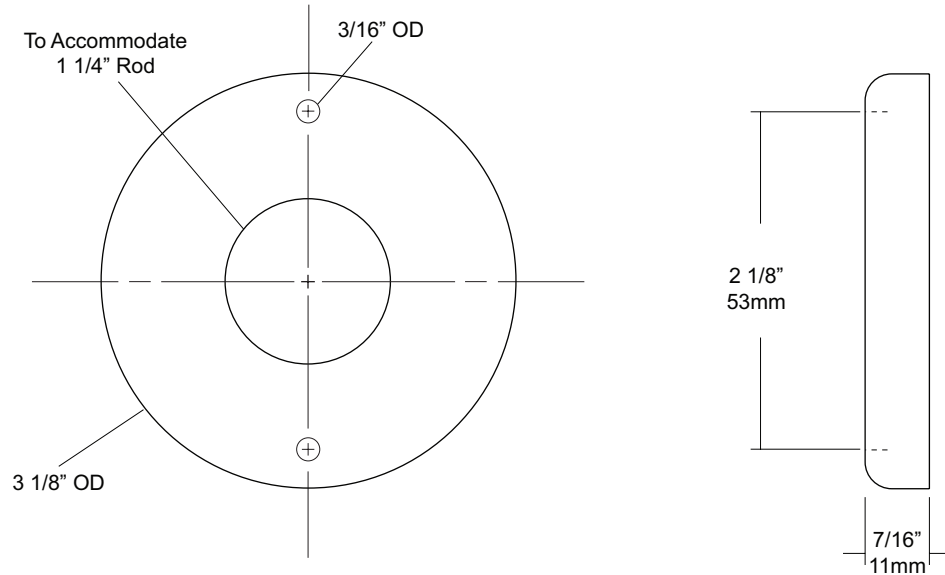

SPECIFICATIONS

Exposed Cover: Fabricated of #22 gauge stainless steel with a #4 satin finish. Cover has two (2) exposed mounting points.

Shower Rod: Fabricated of stainless steel with a #4 satin finish.

UX2: 1 1/4" outside diameter

INSTALLATION

Provide an area on wall surface at desired or specified location. Hold flange to wall surface and transfer mounting points. Drill pilot holes. Place flanges on the ends of the rods. Secure flanges to wall surface with proper fasteners per application.

NOTES