

date
projectname
attn
from
fax
email
phone

5/22
SPRINGFELD JOB
JED
Coldwater Lumber Co

TYLERW@COLDWATERLUMBER.NET
4196782306



U128PC

Vanity Mounted Soap Dispenser

Revision 04/11

JOB #:

ITEM #:

QUANTITY:

MOUNTING	HANDING	TYPE	SIZE	OTHER

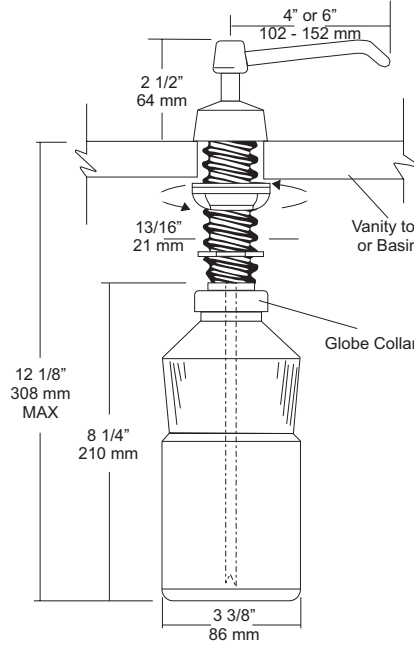

SPECIFICATIONS

Piston & Spout: Highly polished corrosion resistant, stainless steel. Assembly rotates 360 degrees.

Flange & Collar: One piece highly polished chrome on brass.

Valve Assembly: All purpose bellows valve, fabricated of ABS material, with stainless steel return spring.

Shank: Chrome on brass, secured to collar. Special key provided that unlocks collar for servicing.

Globe & Collar: High impact translucent polyethylene.

Capacity: 34 fl oz

U128PCA: Same as U128PC with 6" (152mm) spout.

Recommend type soaps without chloric solutions for proper operation.

***All vanity soap dispensers are designed to be serviced above the counter**

INSTALLATION

Provide a 7/8" - 1" diameter opening in vanity or basin. Insert shank through cut out and secure with supplied washers and wing nut. Connect supply tube with valve making sure notch end is at bottom. Secure globe and collar to shank. Fill globe above counter. Secure upper assembly to shank. Prime dispenser every time unit is serviced.

*It is not recommended to mount any soap dispenser on mirrors

**For best performance, use pre-mixed low concentrate solutions. Dispensers should have periodic maintenance performed to insure the life dispenser. Rinse out globe and valve with warm water to avoid sludge buildup.

Preventative Maintenance: Each dispenser should be flushed out aprx. Every 30 days with warm water to prevent valve from clogging with old soap. Do not use abrasive cleaners to clean dispenser.

NOTES

Formerly Model #: U128-PC

JOB #:

ITEM #:

QUANTITY:

MOUNTING	HANDING	TYPE	SIZE	OTHER

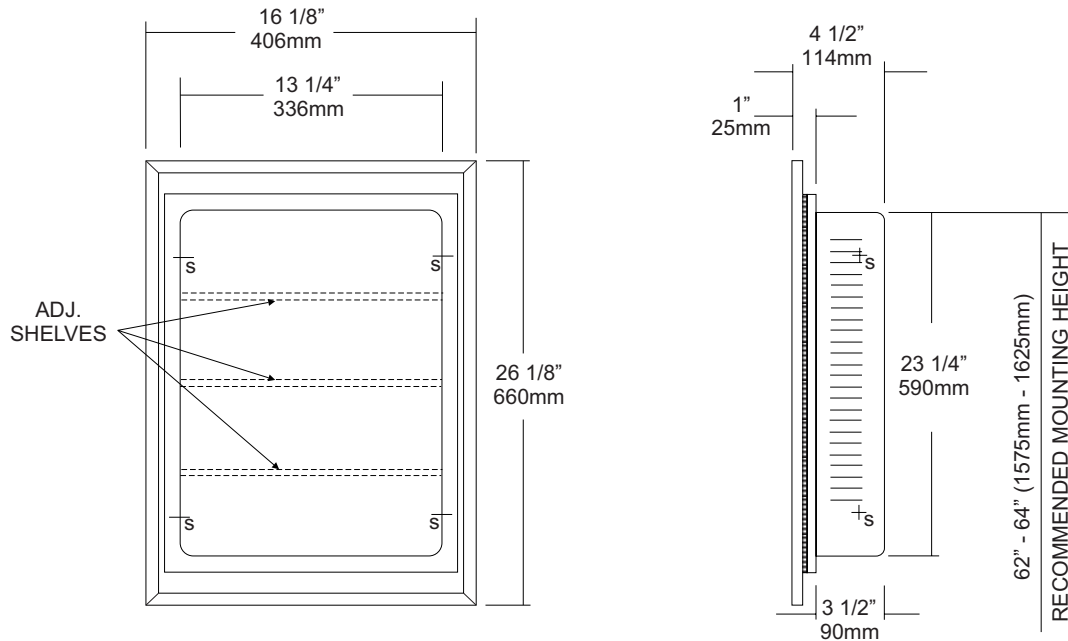

SPECIFICATIONS

Body: Fabricated of one piece deep drawn steel construction, oven baked enamel finish. Integral louvers to accommodate adjustable shelves.

Mirror Door: Float plate glass, silver coated and sealed electrolytic cooper plating. Door is secured by means of a magnetic catch.

Frame: Bright stainless steel finish.

Hinges: Heavy duty piano type hinges.

Shelving: Steel construction to match cabinet body with all edges deburred to prevent injury.

Overall Size: 16"W x 26"H x 4 5/8"D

406mm x 660mm x 114mm

Wall Opening: 14"W x 24"H x 3 3/4"D

356mm x 610mm x 95mm

Shelving: 3 adjustable

INSTALLATION

Coordinate installation with architect and or contractor. Provide wall opening 14"W x 24"H x 3 3/4"D that will allow cabinet to swing left or right without interference. Place cabinet in wall opening and secure with proper fasteners per application. Place unit on wall surface and make sure unit is level. Transfer mounting points and drill pilot holes. Secure unit to surface using proper fasteners per application.

To meet ADA code, a usable shelf on cabinet cannot be any higher than 44" (1120mm) above the finished floor. (4.2.4)

NOTES

UB32 Series Heavy Duty Towel Bar

Revision 03/11

JOB #:

ITEM #:

QUANTITY:

MOUNTING	HANDING	TYPE	SIZE	OTHER

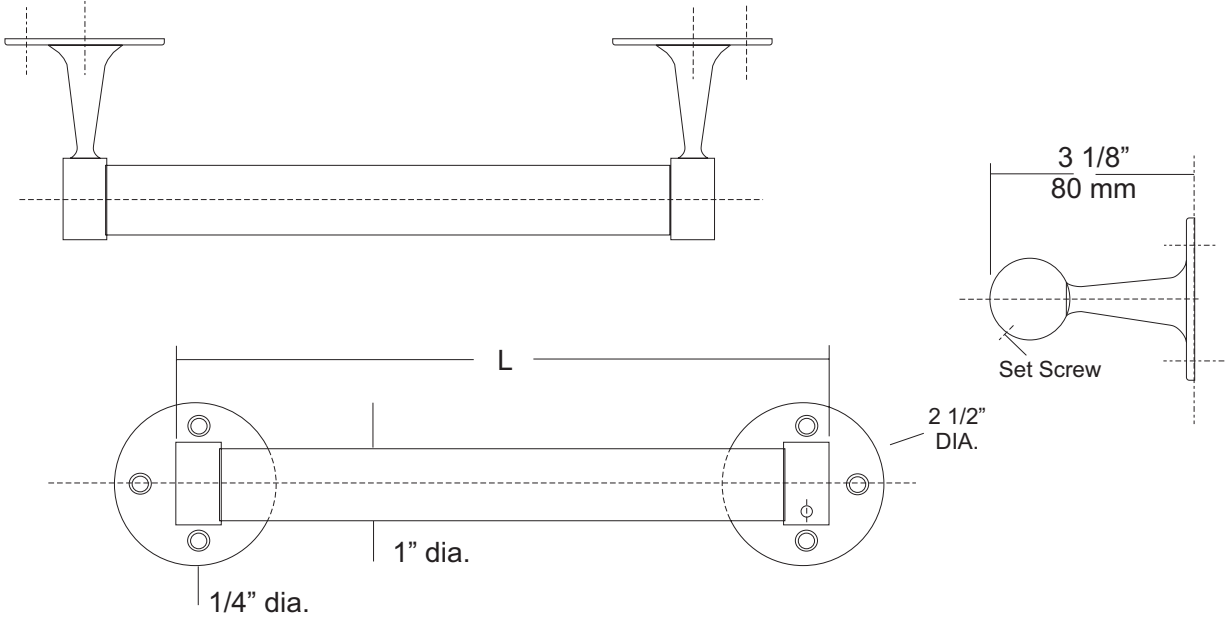

SPECIFICATIONS

Posts: Fabricated of solid forged brass finished with a chrome plated bright finish. Mounting flange is equipped with three countersunk mounting points. (1/4" Dia.). One post is equipped with a set screw to prevent bar from rotating.

Bar: Fabricated of #18 ga stainless steel with a bright finish. Diameter of bar is 1" (26mm)

Standard Lengths: 18", 24", 30", 36"

UB32-SF: Same as UB32 with satin finish

INSTALLATION

Place towel bar inside the post ends and hold up to mounting surface. Making sure unit is level, transfer mounting points from each flange and drill pilot holes. Secure one to mounting surface with proper fasteners per application. Insert bar into mounted post and slide other post over bar. Holding post against wall, secure flange to wall.

NOTES

Formerly Model #: UBK6000 Series



UC12

Double Robe Hook

Revision 03/11

JOB #:

ITEM #:

QUANTITY:

MOUNTING	HANDING	TYPE	SIZE	OTHER

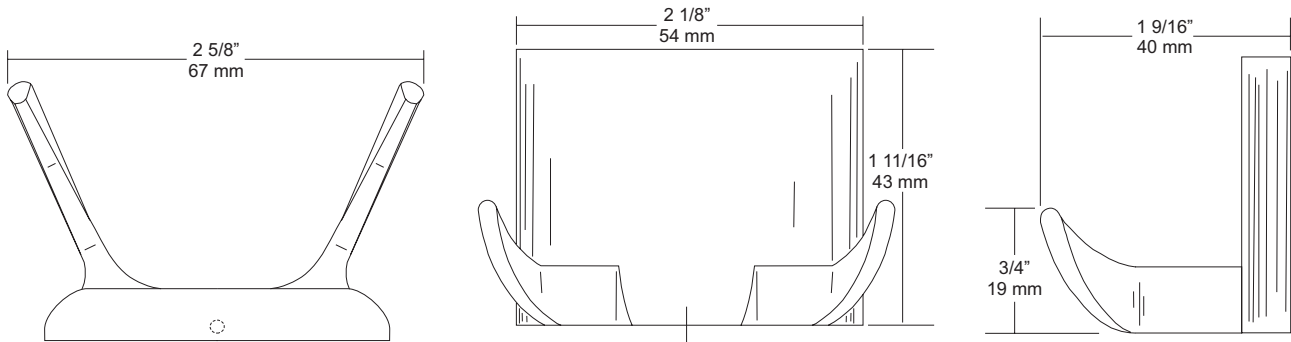

SPECIFICATIONS

UC Accessories: All accessories are fabricated of high polished chrome plating over virgin zinc die cast. All UC items comply with standard federal specifications.

Overall Size: 2 5/8"W x 1 11/16"H x 2 9/16"D
67mm x 44mm x 40mm

INSTALLATION

Place concealed mounting bracket on wall surface at desired location. Transfer mounting points and drill pilot holes. Secure plate with proper fasteners per application. Place item over plate making sure it fits snugly and secure on the underside with supplied set screw.

NOTES



UC30
Towel Ring

Revision 03/11

JOB #:

ITEM #:

QUANTITY:

MOUNTING	HANDING	TYPE	SIZE	OTHER

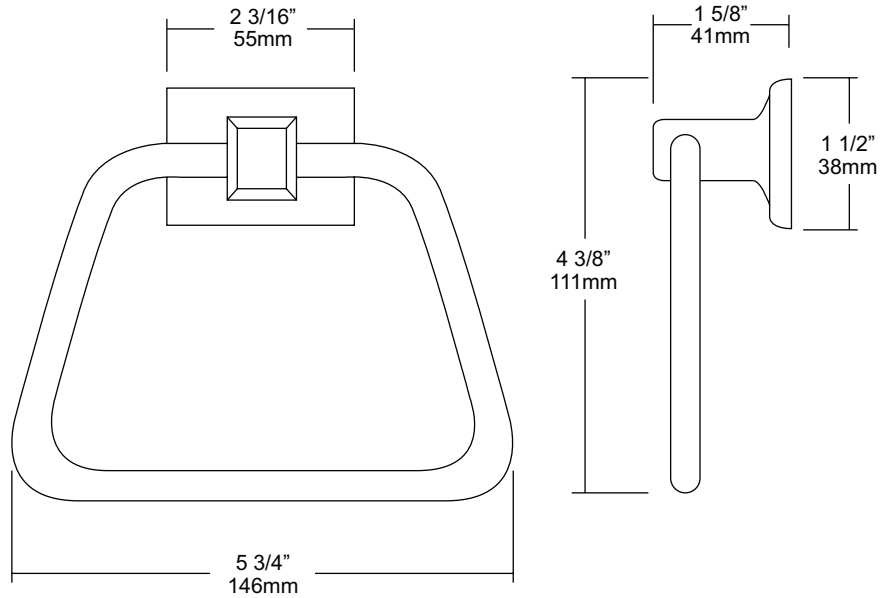

SPECIFICATIONS **INSTALLATION**

UC Accessories: All accessories are fabricated of high polished chrome plating over virgin zinc die cast. All UC items comply with standard federal specifications.

Overall Size: 5 3/4"W x 4 3/8"H x 1 5/8"D

146mm x 110mm x 43mm

Place concealed mounting bracket on wall surface at desired location. Transfer mounting points and drill pilot holes. Secure plate with proper fasteners per application. Place item over plate making sure it fits snugly and secure on the underside with supplied set screw.

NOTES



UC41

Toilet Tissue Dispenser

Revision 03/11

JOB #:

ITEM #:

QUANTITY:

MOUNTING	HANDING	TYPE	SIZE	OTHER

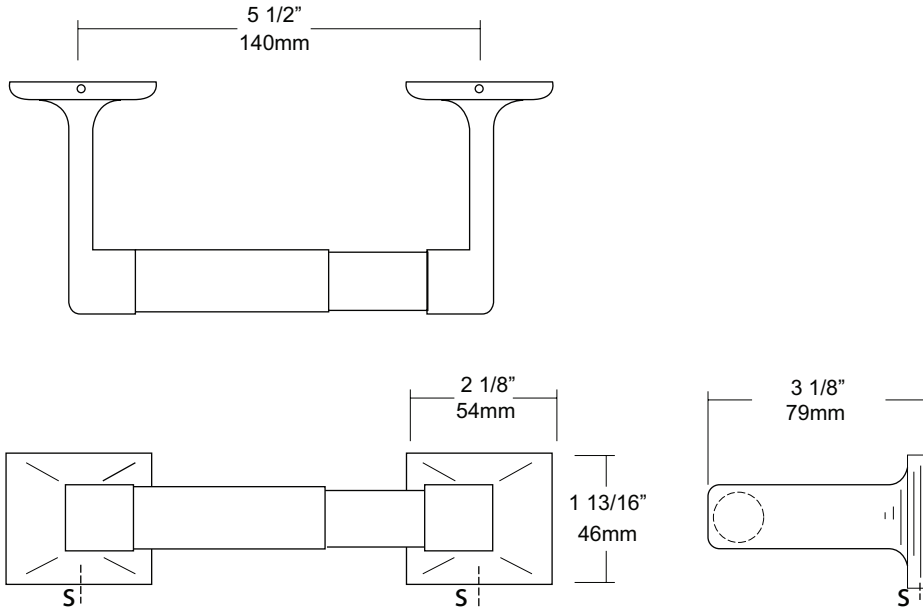

SPECIFICATIONS

UC Accessories: All accessories are fabricated of high polished chrome plating over virgin zinc die cast. All UC items comply with standard federal specifications.

Rollers: White ABS rollers with heavy duty internal spring. Optional chrome plated roller available on request.

Optional U007 Theft Resistant Adapter: Prevents spindle from being removed until roll has been depleted.

Overall Size: 7 5/8"W x 1 13/16"H x 3 1/8"D (without roll)

195mm x 44mm x 79mm

Capacity: One standard roll with a 5 1/4" (133mm) OD

INSTALLATION

Place concealed mounting bracket on wall surface at desired location. Transfer mounting points and drill pilot holes. Secure plate with proper fasteners per application. Place item over plate making sure it fits snugly and secure on the underside with supplied set screw. Do this three times maintaining a 5 1/2" space centerline between posts. Make sure the post you select to be mounted as center post will accommodate two rolls and not the end post.

Toilet Paper Dispensers: All dispensers that are to meet ADA code cannot have any type of controlled delivery. (4.16)

NOTES



UG2-A

Grab Bars

Revised 03/11

JOB #:

ITEM #:

QUANTITY:

MOUNTING	HANDING	TYPE	SIZE	OTHER



SPECIFICATIONS & INSTALLATION

tubing: Fabricated of #18 ga stainless steel with a #4 satin finish. Available in 1 1/4" outside diameter. All bends are formed by an automatic mandrel bending process. All bars maintain a constant 1 1/2" offset.

Finish: Standard finish is a #4 satin finish. For a non-slip finish (peened) add suffix X to model number. (Ex. UG2X-A)

Flanges: Snap flanges are fabricated of 3" diameter, 3/8" deep drawn #22 ga stainless steel with #4 satin finish to match tubing. Flanges have dimples that secure over mounting plate.

Strength: Bars with a 1 1/2" offset clearance will support loads in excess of 900lbs when properly installed. Bars with greater offsets will support loads up to 250lbs when properly installed.

Installation: Before installing grab bars, verify with all state and local codes for requirements on bar diameter and type finish. Recommended mounting heights for grab bars are 33" - 36" centerline above finished floor. All mounting of grab bars when possible should have in wall mounting back plates. Find centerline mounting points and place bar on line making sure to be on center. Transfer mounting points (3 per flange) to wall. Drill pilot holes and secure bar with proper anchors per application. Snap cover over mounting plate.

Standard Lengths (Other sizes available upon request): 12", 16", 18", 24", 30", 32", 36", 42", 48", 50", 52", 54", 56"

FLANGE INFORMATION

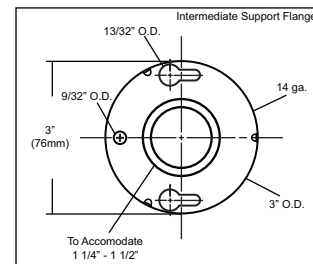
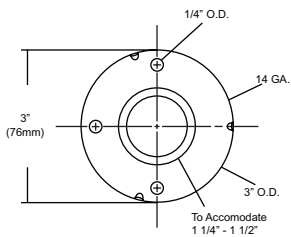
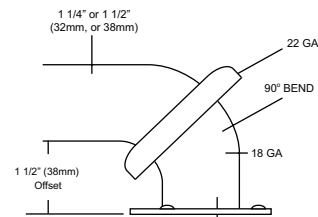

NOTES



UG20-A

Grab Bars

Revised 03/11

JOB #:

ITEM #:

QUANTITY:

MOUNTING	HANDING	TYPE	SIZE	OTHER



SPECIFICATIONS & INSTALLATION

Tubing: Fabricated of #18 ga stainless steel with a #4 satin finish. Available in 1 1/4" outside diameter. All bends are formed by an automatic mandrel bending process. All bars maintain a constant 1 1/2" offset.

Finish: Standard finish is a #4 satin finish. For a non-slip finish (peened) add suffix X to model number. (Ex. UG20X-A)

Flange: Flanges are fabricated of 3" diameter, 1/2" drawn #11 ga stainless steel with #4 satin finish to match tubing. Flanges are heliarc welded to bar to form a one piece construction. Each flange is secured to concealed mounting plate with four (4) 1/4"-20 stainless steel tamper resistant set screws.

Strength: Bars with a 1 1/2" offset clearance will support loads in excess of 900lbs when properly installed. Bars with greater offsets will support loads up to 250lbs when properly installed.

Installation: Before installing grab bars, verify with all state and local codes for requirements on bar diameter and type finish. Recommended mounting heights for grab bars are 33" - 36" centerline above finished floor. All mounting of grab bars when possible should have in wall mounting back plates. Secure mounting plate to wall surface at specified location with proper anchors (snugly) until proper centerline dimension is achieved. Place bar over plates and secure with supplied set screws. (4 per flange).

Standard Lengths (Other sizes available upon request): 12", 16", 18", 24", 30", 32", 36", 42", 48", 50", 52", 54", 56"

FLANGE INFORMATION

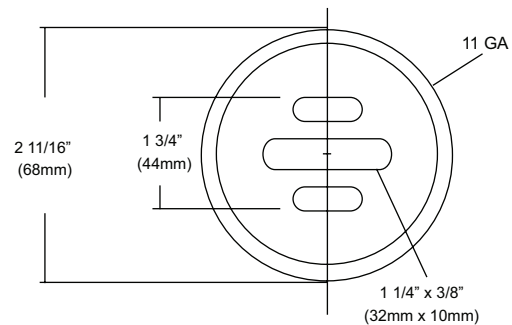
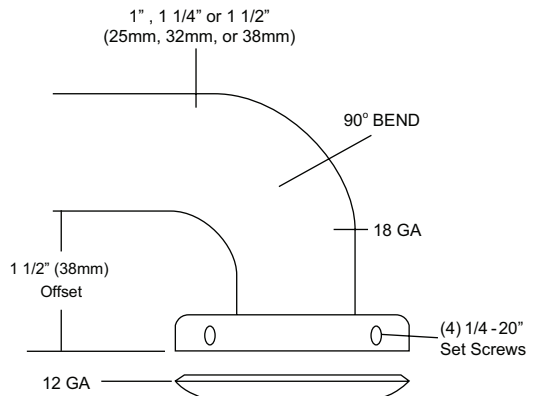

NOTES