

date  
projectname  
attn  
from  
fax  
email  
phone

7/7  
Phillips K-5  
Bob  
bob@neffspecialties.com  
  
bob@neffspecialties.com





# U7018B

## Installation Instruction Sheet

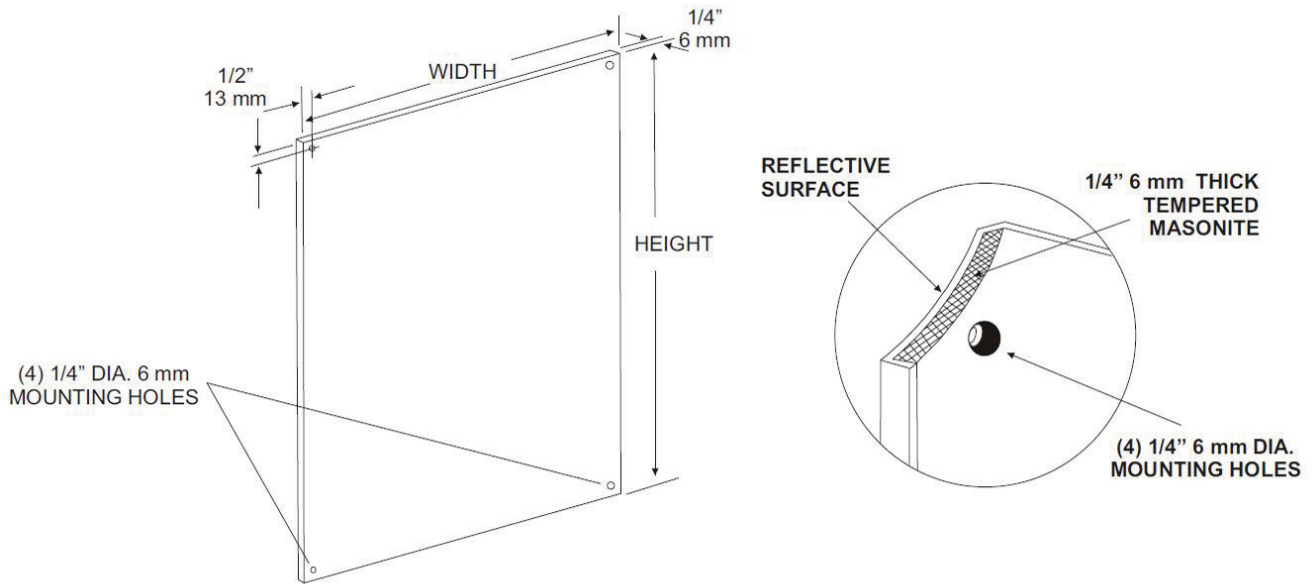

### INSTALLATION

Provide an area at desired or specified location and strike a line that is level. Place mirror at this line and check again with level. Transfer mounting locations to wall surface and drill pilot holes. Peel off vinyl coating around corners only before securing to wall. Secure mirror with proper fasteners per each application. Remove remainder of vinyl coating after mirror checks with level and is properly secured. The bottom reflective surface edge must be mounted no higher than 40" above finished floor to comply with ADA code, 4.19.6.

### CARE & CLEANING

Wipe mirrors with a soft cloth, taking special care not to rub stainless steel mirrors in a circular motions to avoid scratching. Do not use abrasive cleaners containing chloric solutions on stainless steel mirrors. Glass Plus or other window cleaning products are ideal.



# U705 Series Angle Frame Mirror & Shelf

Revision 11/15

JOB #:

ITEM #:

QUANTITY:

MOUNTING	HANDING	TYPE	SIZE	OTHER

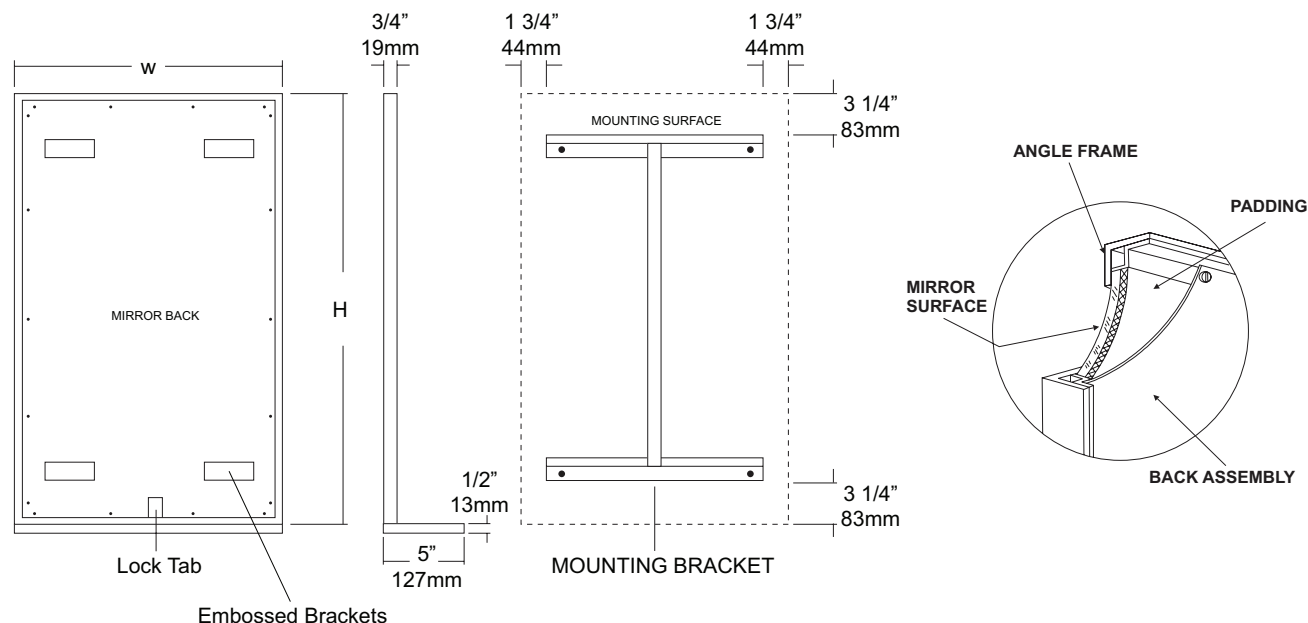

## SPECIFICATIONS

**Frame:** Fabricated of #18 ga stainless steel, #4 satin finish. 3/4" x 3/4" frame with welded mitered corners are ground and polished smooth. #22 ga concealed "Z" channel is spot welded to frame for greater rigidity.

**Mirror:** 1/4" thick type 1 transparent flat type, class 1 - clear glass mirrors. Mirror is coated with silver and sealed with a uniform electrolytic copper plating, along with two coats of paint for added protection. Mirrors are guaranteed against silver spoilage for a period of 15 years. Mirrors conform to ASTM C1036 and ASTM C1503-R8.

**Shelf:** #18 ga stainless steel with #4 satin finish. Shelf is 5"D x full width of mirror. All edges are turned down 1/2" with front edge turned back 1/2" for rigidity and prevents possible injury. #18 ga support bracket is welded to both frame and shelf then ground smooth.

**Filler:** 3/16" thick full size, shock absorbing, water resistant, non-abrasive polyethylene padding protects all concealed mirror surfaces.

**Back:** #20 ga pre-plated galvanized steel, with embossed horizontal louver mounting brackets. Embossed theft resistant pressure activated clip lock device, locks mirror in place to wall hangers.

**Hangers:** Fabricated of #20 ga pre-plated galv. steel.

**Standard Sizes Available (W x H):** 16"x24", 16"x30", 18"x24", 18"x30", 18"x36", 24"x30", 24"x36"

### Options:

**LG:** Laminated Glass

**LX:** Polycarbonate

**PM:** Plastic Acrylic

**T:** Tempered Glass

**VC:** Vinyl Clad (Safety Glass)

**8B:** #8 Reflective Stainless Steel

\*Stainless steel mirrors reflect images in different optic quality than plate glass. There will be a slight distortion which increases proportionately with the mirror size. Therefore, AJW Architectural Products™ cannot be held responsible for quality of image.

\*\*Mirrors are always ordered Width x Height

\*\*\*Recommended max size for 8B mirrors: 72" x 47'-1/2"

\*\*\*\*Framed mirrors are fabricated to a tolerance of (+/-) 1/8"

\*\*\*\*\* Mirrors conform to Federal Specifications DD-M-00411b & DD-g-541D

## INSTALLATION

Coordinate installation with architect / contractor for specific mounting location and height for each mirror application. Making sure "I" bracket is level, transfer all mounting point locations to wall surface from drawing. Secure brackets with proper fasteners for each application. Slide mirror down over horizontal brackets until clip lock secures mirror in place. Mirror can only be removed by inserting tool through hole at bottom of frame depressing clip. This will allow mirror to slide up over brackets. Fillers are available if mirrors are mounted above and below tile line. (U004 Filler) filler material will match mirror frame to form a one piece construction.

To meet ADA Code, bottom edge of reflective surface can be no higher than 40" above finished floor. (4.19.6) Full length mirrors may be used for universal application when installed in correct locations.

Abrasive cleaners & chloric solutions should not be used on mirrors. Discoloring and /or scratching of frame and reflective surface may occur.

## NOTES

# U705 Installation Instruction Sheet

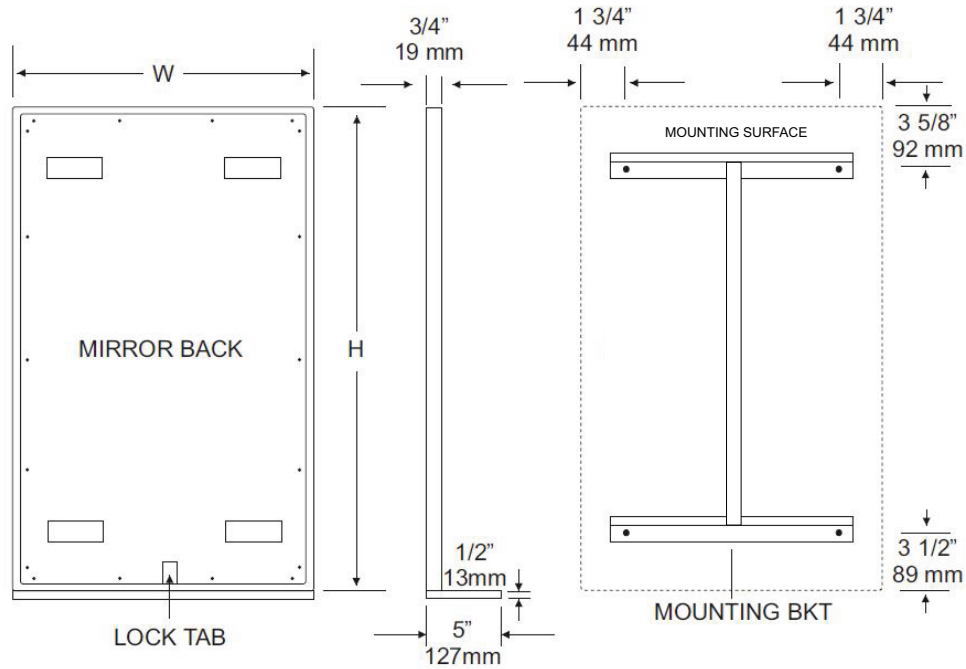

## INSTALLATION

Coordinate installation with architect / contractor for specific mounting location and height for each mirror application. Making sure "I" bracket is level, transfer all mounting point locations to wall surface from drawing. Secure brackets with proper fasteners for each application. Slide mirror down over horizontal brackets until clip lock secures mirror in place. Mirror can only be removed by inserting tool through hole at bottom of frame depressing clip. This will allow mirror to slide up over brackets. Fillers are available if mirrors are mounted above and below tile line. (U004 Filler) Filler material will match mirror frame to form a one piece construction.

To meet ADA Code, bottom edge of reflective surface can be no higher than 40" above finished floor. (4.19.6) Full length mirrors may be used for universal application when installed in correct locations.

## CARE & CLEANING

Wipe mirrors with a soft cloth, taking special care to rub stainless steel frames with the grain to avoid scratching. Do not use abrasive cleaners containing chloric solutions on stainless steel frames. Glass Plus or other window cleaning products are ideal.



# UG2-A

Grab Bars

Revised 03/11

JOB #:

ITEM #:

QUANTITY:

MOUNTING	HANDING	TYPE	SIZE	OTHER



## SPECIFICATIONS & INSTALLATION

**Tubing:** Fabricated of #18 ga stainless steel with a #4 satin finish. Available in 1 1/4" outside diameter. All bends are formed by an automatic mandrel bending process. All bars maintain a constant 1 1/2" offset.

**Finish:** Standard finish is a #4 satin finish. For a non-slip finish (peened) add suffix X to model number. (Ex. UG2X-A)

**Flanges:** Snap flanges are fabricated of 3" diameter, 3/8" deep drawn #22 ga stainless steel with #4 satin finish to match tubing. Flanges have dimples that secure over mounting plate.

**Strength:** Bars with a 1 1/2" offset clearance will support loads in excess of 900lbs when properly installed. Bars with greater offsets will support loads up to 250lbs when properly installed.

**Installation:** Before installing grab bars, verify with all state and local codes for requirements on bar diameter and type finish. Recommended mounting heights for grab bars are 33" - 36" centerline above finished floor. All mounting of grab bars when possible should have in wall mounting back plates. Find centerline mounting points and place bar on line making sure to be on center. Transfer mounting points (3 per flange) to wall. Drill pilot holes and secure bar with proper anchors per application. Snap cover over mounting plate.

**Standard Lengths (Other sizes available upon request):** 12", 16", 18", 24", 30", 32", 36", 42", 48", 50", 52", 54", 56"

## FLANGE INFORMATION

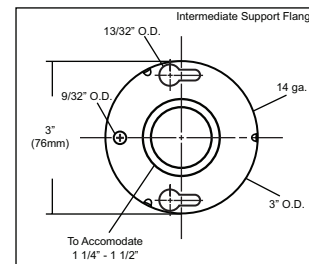
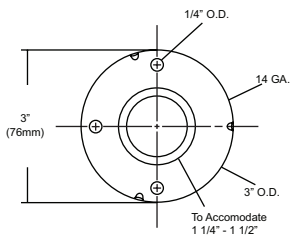
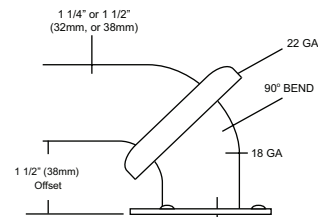

## NOTES



# UJ45 Series

## Mop Holder & Hook Strip Combination Unit

Revision 03/11

JOB #:

ITEM #:

QUANTITY:

MOUNTING	HANDING	TYPE	SIZE	OTHER

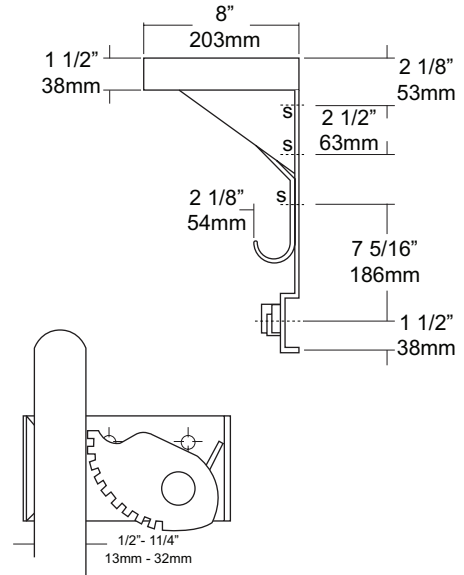
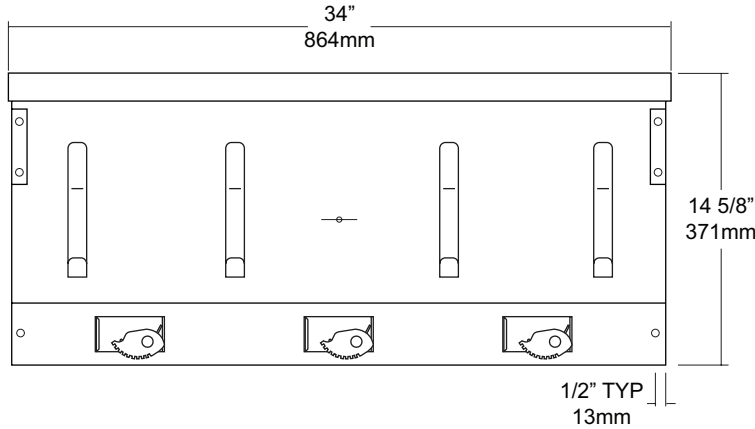

### SPECIFICATIONS

**Shelf:** Fabricated of #18 ga stainless steel with a #4 satin finish, 8" deep (203mm) bent down 1 1/2" with 1/2" returns back for rigidity and safety.

**Back:** Fabricated of #18 ga stainless steel, #4 satin finish. Lower portion has a formed channel for added rigidity to support the mop holders.

**Mop Holders:** UJ19 plated reinforced steel with serrated cam type hard rubber mop or broom holder. Holds handles 1/2" to 1 1/4" diameter.

**Hooks:** #14 ga stainless steel with a #4 satin finish.

**Mounting Brackets:** #16 ga stainless steel with exposed mounting points.

**Verify Style:**

**UJ45A:** 34"L (864mm) with 3 holders, 4 hooks.

**UJ45B:** 44"L (1118mm) with 4 holders, 5 hooks.

**UJ45C:** 54"L (1372mm) with 5 holders, 6 hooks.

### INSTALLATION

Place unit to wall surface making sure unit is level and transfer mounting points. Drill pilot holes and secure unit with proper fasteners per application.

### NOTES





# UX116-BF

Heavy Duty Coat Hook

Revision 03/11

JOB #:

ITEM #:

QUANTITY:

MOUNTING	HANDING	TYPE	SIZE	OTHER

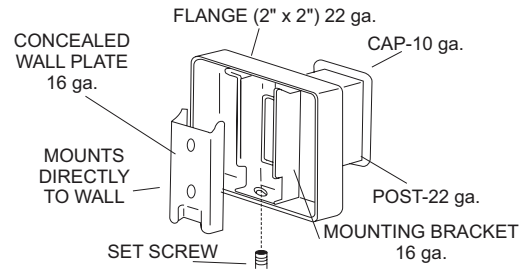
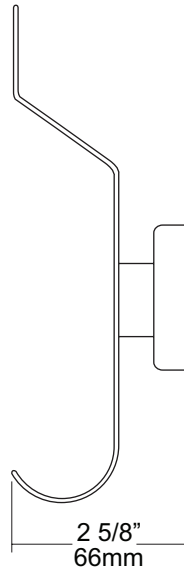
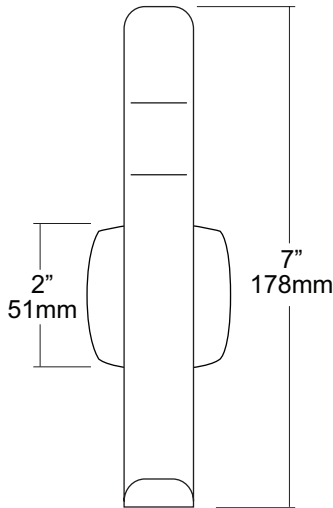

### SPECIFICATIONS

**UX Accessories:** All UX bath accessories series are fabricated of stainless steel with a bright or satin finish. Mounting plates are concealed with a snap-on type plate secured by a set screw.

**Hook:** #10 ga stainless steel hook.

**Flange:** 2" x 2" flange #22 ga stainless steel.

**Post:** #22 ga stainless steel.

**Mounting Plate:** #16 ga stainless steel concealed wall plate. Set screw secures mounting plate and flange.

**Overall Size:** 2"W x 7"H x 2 5/8"D

**51mm x 178mm x 66mm**

**UX116-SF:** Same as UX116-BF with satin finish.

### INSTALLATION

Provide an area on wall surface at desired or specified location. Place concealed mounting plate on wall surface and transfer mounting points. Drill pilot holes and secure with proper fasteners. Place snap on flange over plate and secure with set screw.

### NOTES