

date  
projectname  
attn  
from  
fax  
email  
phone

2-6  
warranty  
Becky

# STORAGE SYSTEMS



**AJW**  
.....  
Architectural Products™



## ▶ **Culture • Focus • Results™**

At AJW, our culture is our company. With that in mind, we focus on the mechanics that support a high-performance team. Transparency, communication, discipline, and focus are cornerstones of our operational behavior.



# TABLE OF CONTENTS

<b>About AJW</b> .....	<b>1</b>	<b>Top and Base Options</b> .....	<b>13</b>
<b>Storage Systems Overview</b> .....	<b>3</b>	<b>Handle and Locker Latch Details</b> .....	<b>14</b>
<b>Standard Series Lockers</b> .....	<b>5</b>	<b>Trim and Filler Panel Details</b> .....	<b>15</b>
<b>Athletic Series Lockers</b> .....	<b>7</b>	<b>Accessory Details</b> .....	<b>16</b>
<b>Professional Series Lockers</b> .....	<b>9</b>	<b>Bench Top and Pedestal Details</b> .....	<b>17</b>
<b>TA-50 Series Lockers</b> .....	<b>10</b>	<b>Lock Options</b> .....	<b>18</b>
<b>Standard Locker Colors</b> .....	<b>11</b>	<b>Ventilation Options</b> .....	<b>18</b>
<b>Bench Top Colors</b> .....	<b>12</b>	<b>Size Charts</b> .....	<b>19</b>



## **▶ American Manufacturing**

With manufacturing facilities in New York and Texas, AJW can respond with agility and precision to even the most complex initiatives. From high-style custom projects to a demanding scope of work, AJW has the team, infrastructure and experience to deliver results you can be confident in.

## **▶ Intelligent Sourcing**

At AJW, we build partnerships that last. Many of our legacy partners have complemented our manufacturing capabilities for nearly 50 years. Consequently, we continue to leverage the depth, breadth, and strength of our supply chain to drive results and expand our distribution network globally.

## **▶ Better Results**

High performance results are our priority. American manufacturing and intelligent sourcing allow us to leverage our in-house capabilities and our proven network of partners so that we are able to respond when it counts.



# Focused on Service<sup>SM</sup>

## ▶ We Are AJW

For nearly 50 years, we have Focused on Service<sup>SM</sup>. As a result, our infrastructure is customer driven. We listen so that we understand your goals and objectives. We tailor our efforts and direct our action to be in concert with your needs. We measure our success by the health of our partnerships. American manufacturing, precise supply chain management and a focused culture are the fuel for better results. We are AJW.

**AJW**  
Architectural Products<sup>TM</sup>

509 Temple Hill Road

# STORAGE SYSTEMS

## ▾ SPECIFICATIONS

### ADA Information

Shelf and coat hooks are placed no lower than 48" above the finished floor.

An additional shelf is installed no lower than 15" above the finished floor.

AJW recessed handles are operable with one hand and do not require grasping or twisting of the wrist, or more than 5 lbs of force to operate.

At least 5% of the lockers supplied for a project, but no less than one, will meet ADA requirements.

---

### Knocked Down vs. All Welded Lockers

Knocked Down lockers require field assembly with rivets or nuts and bolts.

All welded lockers are fabricated of a single construction with welded connections.

# STORAGE SYSTEMS

## STANDARD SERIES



AJW Metal Lockers are fabricated from high quality mild cold rolled steel and are engineered for durability. Our Standard Series lockers are available in a broad selection of sizes to meet the requirements of any typical locker application.

## ATHLETIC SERIES



Rugged environments demand rugged solutions. AJW Athletic Series lockers offer practical features including ventilation, visibility, and strength – perfect for storage of athletic gear, or other heavy duty use.

## PROFESSIONAL SERIES



With an open front, and perforated sides - the AJW Professional Series locker is designed for easy access to uniforms and equipment. Popular options include a lockable security box and a lockable foot locker that also functions as a bench.

## TA-50 SERIES



AJW TA-50 Series lockers offer ample space to store equipment for military and law enforcement agencies, and are built to last the lifetime of your facility. Popular options include heavy duty shelves, coat rods, and a security three point latching system.



# STORAGE SYSTEMS

## STANDARD SERIES LOCKERS SPECIFICATIONS

### Body:

Entire unit (bottom, sides, top, back, and shelves) constructed of mild cold rolled 24 ga. commercial grade steel. Bolt spacing will not exceed 9" on center.

### Door:

Cold rolled 16 ga. commercial grade steel. Channel shaped on lock and hinge side with angle formations across the top and bottom. Each door will have a polished aluminum number plate riveted to the face of the door with 1/2" high black numerals. Optional ventilation styles available. (14 ga. non-ventilated commercial grade steel door available).

### Door Frame:

Cold rolled 16 ga. commercial grade steel. Channel shaped with vertical sides having an additional flange to act as a continuous door strike.

### Finish:

Commercial grade steel cleaned and treated with a phosphate process. Finished coat baked on, powder coated enamel.

### Color:

Doors and exposed parts available in colors from AJW standard color selection.

### Hinges:

2" five knuckle hinge pairs: 2 per door (3 pairs on doors 48" H or larger), or full length 16 ga. piano hinge, riveted to frame and welded to door.

### Latch / Handle:

20 ga. deep drawn stainless steel cup, able to accommodate locks. 14 ga. steel lifting trigger. Padlock eye to accommodate 5/16" diameter padlock shackle. Three point latch mechanism, engaging the frame at (3) points on doors greater than 42" in height; (2) engaging points on all other doors. Rubber silencer attached to frame at each latch hook location. Single Point Latch available - 11 ga. steel hook with padlock hasp welded to door frame. Padlock hasp protrudes through stainless steel cup.

### Interior:

Shelves included on all lockers 48" H and up. Two wall hooks and one ceiling hook included on all lockers. Coat rod included on all lockers 18"D or greater.

### Assembly:

All locker components assembled with rivets or nuts and bolts. All welded construction as a single unit available.

# STORAGE SYSTEMS

## STANDARD SERIES LOCKERS

AJW Metal Lockers are fabricated from high quality mild cold rolled steel and are engineered for durability. Our Standard Series lockers are available in a broad selection of sizes to meet the requirements of any typical locker application.

### Configurations Available

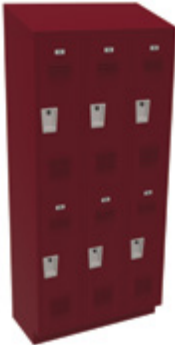

Two Tier



Three Tier



Four Tier

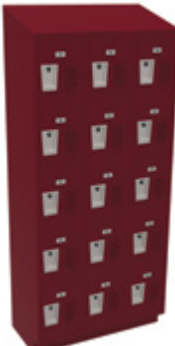

Five Tier



Six Tier



Two Person



One Tier



16 Person



Wall Mount

# STORAGE SYSTEMS

## ATHLETIC SERIES LOCKER SPECIFICATIONS

### Body:

Backs constructed of mild cold rolled 18 ga. commercial grade steel. Bottom, sides, top and shelves constructed of 16 ga. steel. Bolt spacing will not exceed 9" on center.

### Door:

Cold rolled 16 ga. commercial grade steel. Channel shaped on lock and hinge side with angle formations across the top and bottom. Each door will have a polished aluminum number plate riveted to the face of the door with 1/2" high black numerals.

### Door Frame:

Cold rolled 16 ga. commercial grade steel. Channel shaped with vertical sides having an additional flange to act as a continuous door strike.

### Finish:

Commercial grade steel cleaned and treated with a phosphate process. Finished coat baked on, powder coated enamel.

### Color:

Doors and exposed parts available in colors from AJW standard color selection.

### Hinges:

2" five knuckle hinge pairs: 2 per door (3 pairs on doors 48" or larger), or full length 16 ga. piano hinge, riveted to frame and door.

### Latch / Handle:

20 ga. deep drawn stainless steel cup, able to accommodate locks. 14 ga. stainless steel lifting trigger. Padlock eye to accommodate 5/16" diameter padlock shackle. Three point latch mechanism, engaging the frame at (3) points on doors greater than 42" in height; (2) engaging points on all other doors. Rubber silencer attached to frame at each latch hook location. Single Point Latch available -11 ga. steel hook with padlock hasp welded to door frame. Padlock hasp protrudes through stainless steel cup.

### Interior:

Shelves included on all lockers 48" H and up. Two wall hooks and one double ceiling hook included on all lockers. Coat rod included on all lockers 18"D or greater.

### Assembly:

All locker components assembled with rivets or nuts and bolts. All welded construction as a single unit available.



# STORAGE SYSTEMS

## ATHLETIC SERIES LOCKERS

Rugged environments demand rugged solutions. AJW Athletic Series lockers offer practical features including ventilation, visibility, and strength – perfect for storage of athletic gear or other heavy duty use.

### Configurations Available



One Tier



Two Tier



Three Tier



Four Tier



Five Tier



Six Tier



# STORAGE SYSTEMS

## PROFESSIONAL SERIES LOCKERS

With an open front, and perforated sides, the AJW Professional Series locker is designed for easy access to uniforms and equipment. Popular options include a lockable security box and a lockable foot locker that also functions as a bench.



## PROFESSIONAL SERIES LOCKER SPECIFICATIONS

### Body:

Backs constructed of mild cold rolled 18 ga. commercial grade steel. Bottom, sides, top and shelves constructed of 16 ga. steel. Bottoms have two welded reinforcement channels. Bolt spacing will not exceed 9" on center.

### Frame:

Open front with diamond ventilation pattern on sides.

### Finish:

Commercial grade steel cleaned and treated with a phosphate process. Finished coat baked on, powder coated enamel.

### Color:

Doors and exposed parts available in colors from AJW standard color selection.

### Overhead Security Locker:

14 ga. commercial grade steel door with 16 ga. commercial steel side panel. Door riveted to frame with continuous full length hinge or five knuckle hinge pair. Recessed single point latch. 16 ga. commercial grade steel frame, channel shaped, with vertical sides having an additional flange to act as a continuous door strike. Each door will have black numerals.

### Foot Locker:

Single point latch with padlock strike plate on front panel. Mini louvers on front panel for ventilation. Continuous full length hinge on locker top with rubber silencers at contact points. Two reinforcement channels welded to bottom of seat with two seat supports attached to each side for additional support.

### Interior:

Two wall hooks and one coat rod.

# STORAGE SYSTEMS

## TA-50 SERIES

AJW TA-50 Series lockers offer ample space to store equipment for military and law enforcement agencies, and are built to last the lifetime of your facility. Popular options include heavy duty shelves, coat rods, and a security three point latching system.



## TA-50 SERIES LOCKER SPECIFICATIONS

### Body:

Backs constructed of mild cold rolled 18 ga. commercial grade steel, welded to locker assembly. Bottom formed from 14 ga. steel sheet, welded to locker assembly. Tops are formed from 16 ga. steel sheet, welded to the locker frame, forming an integral stop. Sides are constructed of 13 ga. flattened expanded metal mesh, securely welded to frame. Shelves are formed from 16 ga. steel sheet securely welded to locker sides.

### Doors:

14 ga. diamond perforated double doors, with 18 ga. full height door stiffener. Doors will have one polished aluminum number plate riveted to the face of the door with 1/2" high black numerals.

### Finish:

Commercial grade steel cleaned and treated with a phosphate process. Finished coat baked on, powder coated enamel.

### Color:

Doors and exposed parts are available in AJW's standard colors, Ivory and Steel Grey.

### Hinges:

16 ga. continuous piano hinge, one per door, welded to door, riveted to frame.

### Latch / Handle:

All TA-50 lockers have a security three point turn handle, equipped with two lock rods that engage the top and bottom of the locker frame while a cam engages the frame at the door jamb.

### Interior:

Three wall hooks mounted at back of locker, underneath the shelf. One galvanized metal coat rod welded to mounting brackets below the shelf. All interconnecting hardware is supplied, while installation and anchoring hardware is not.

### Assembly:

All locker components are welded together securely and are fabricated as a single unit.

# STORAGE SYSTEMS

## STANDARD LOCKER COLORS



Grey (0010)



Steel Grey (0011)



Ivory (0012)



Cement Grey (0013)



Taupe (0014)



Fossil Green (0015)



Teal (0016)



Hunter Green (0017)



Colonial Blue (0018)



Dusk Blue (0019)



Marine Blue (0020)



Yellow (0021)



Orange (0022)



Stop Red (0023)



Ruby Red (0024)



Burgundy (0025)



Royal Blue (0026)



Plum Purple (0027)



Winter White (0028)



Jet Black (0029)

# STORAGE SYSTEMS

## ▶ BENCH TOP COLORS

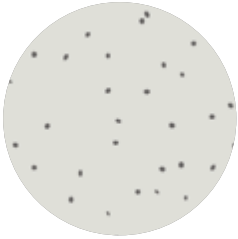

Moonlight Granite

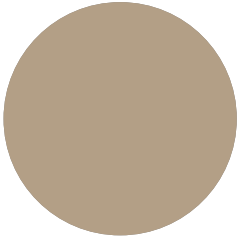

Beige

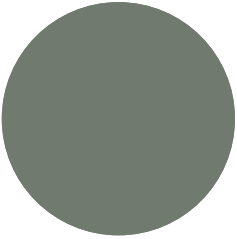

Sage Green

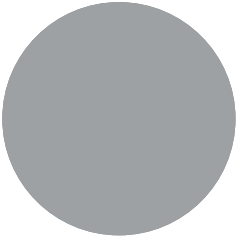

Grey

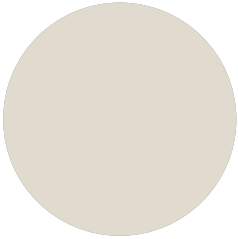

Linen

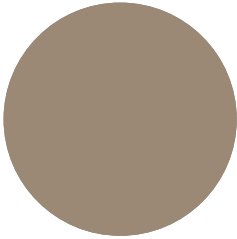

Mocha

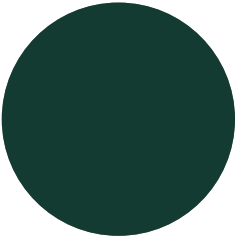

Forest Green

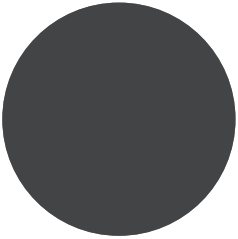

Slate

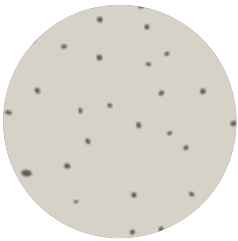

Sandstorm

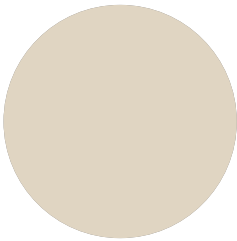

Parchment

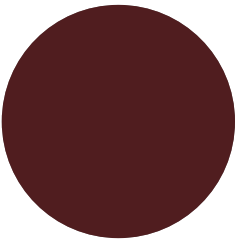

Burgundy



Black Matrix

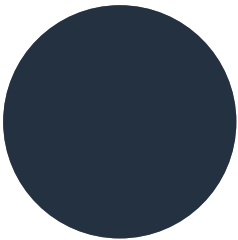

Royal Blue

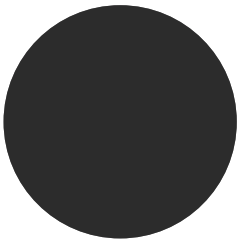

Black

**Note:**  
Color charts are printed approximations  
- actual colors may vary. Please contact  
AJW to request a sample.



# STORAGE SYSTEMS

## TOP OPTIONS

Continuous Slope



Individual Slope



Flat Top



18 ga. commercial grade steel, powder coated to match locker color. Continuous slope tops up to 72" in length (longer lengths connected with splices). Degree of slope is 1/3 of locker depth.

**Note:** Continuous and Individual Slope not available for 16 Person and 2 Person options.

## BASE OPTIONS

4" Z-base



6" Legs



6" Closed Base



- Z-Bases: 16 ga. commercial grade steel.
- 6" Legs: 16 ga. commercial grade steel.
- 6" Closed Base: 18 ga. commercial grade steel.
- All powder coated to match locker color.

# STORAGE SYSTEMS

## ▶ HANDLE AND LOCKER LATCH DETAILS

### Trigger Lift

20 ga. deep drawn stainless steel cup, able to accommodate locks. 14 ga. steel lifting trigger. Padlock eye shackle. Three point latch mechanism, engaging the frame at (3) points on doors greater than 42" in height; (2) engaging points on all other doors.



### Single Point

20 ga. deep drawn stainless steel cup, able to accommodate locks. 11 ga. steel hook with padlock hasp welded to door frame. Padlock hasp protrudes through stainless steel cup.

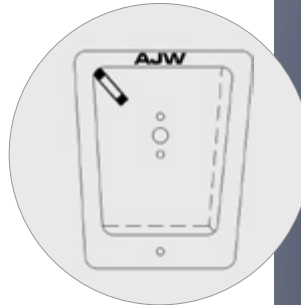

### Security

3-point turn-handle latching engages at frame top, bottom and center side of door, with 3/8" diameter lock rods. 3/16" turn-handle welded to 11 ga. lock plate keeper, welded to center side of frame.

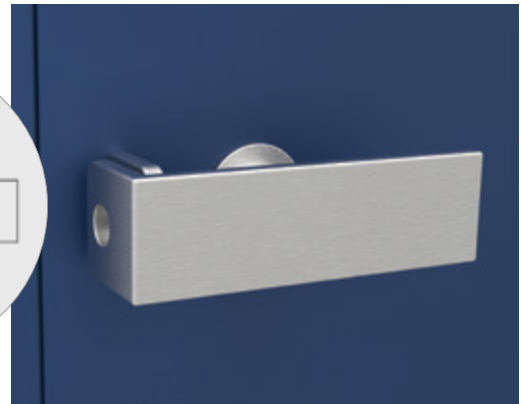
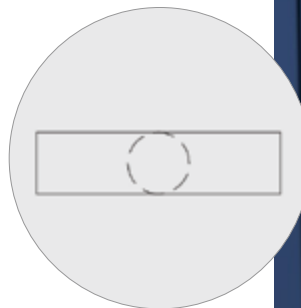

# STORAGE SYSTEMS

## ▶ TRIM DETAILS (RECESSED LOCKERS ONLY)



18 ga. commercial grade steel trim, powder coated to match locker color. Trim face attached to lockers with concealed clips and endcaps.

## ▶ FILLER PANEL DETAILS

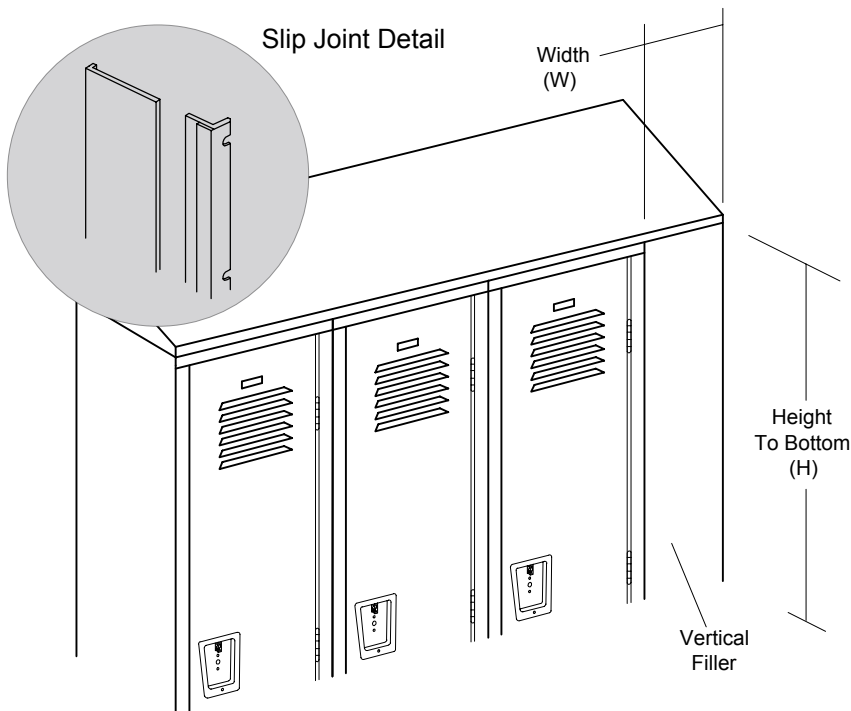

20 ga. commercial grade steel, powder coated to match locker color. Filler formed into an angle and connected with slip joints to create a smooth finish.

# STORAGE SYSTEMS

## ACCESSORY DETAILS

Single Prong Hook

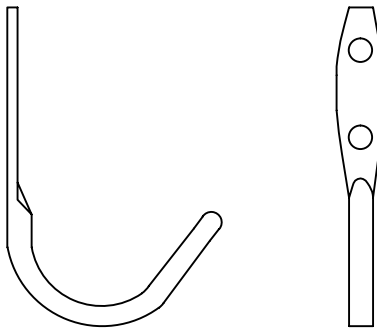

Double Prong Hook

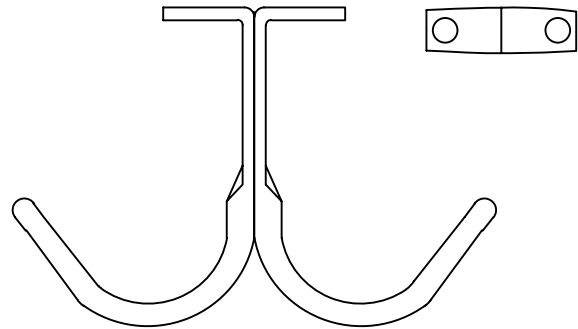

Coat Rod & Hook

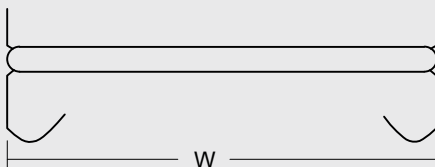
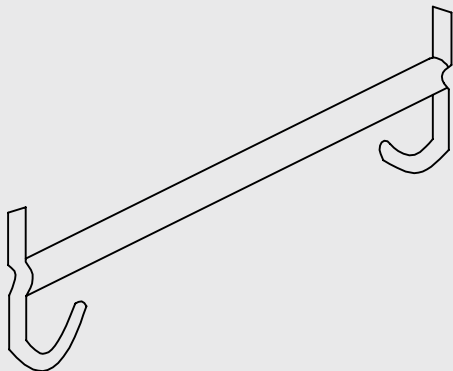

Number Plates

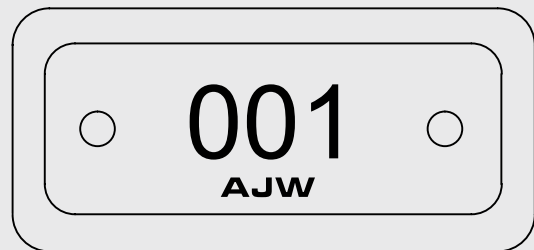

Hooks - Zinc plated.

Coat Rod & Hook - Zinc plated.

Number Plate - Polished aluminium with 1/2" high black numerals.



# STORAGE SYSTEMS

## ► BENCH TOP DETAILS



- 1" thick HDPE, or 1 1/4" thick mixed hardwood (finished with (2) coats of clear lacquer).
- 9 1/2" width standard; custom sizes available.
- 20" and 24" width ADA benches available.
- Benches with backs available.

### Plastic Top

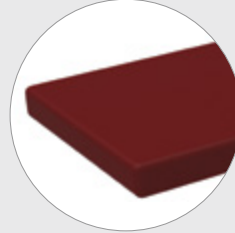

1" thick solid plastic (HDPE), with 1/4" radiused edges.

### Hardwood Top



1 1/4" thick hardwood, with two coats of clear lacquer.

## ► PEDESTAL DETAILS

### Steel



Pedestal fabricated of 1-1/2" diameter steel tubing with 10 ga. steel flanges welded to each end. 16-1/4" high; powder coated to match lockers, or available in our standard black and almond colors.

### Stainless Steel



Stainless Steel, #4 Satin Finish, 2" wide, 16 ga. brushed stainless steel, 16 1/4" high formed to trapezoidal shape. Pedestal has four mounting holes in the top for fastening to the bench, and four holes on the bottom, for mounting into the floor.

### Wall Mounted



1 1/2" wide reversible steel bracket. Span between brackets not recommended to exceed four feet. Available in black, almond, or stainless steel.

Pedestal Colors:



Black

Almond

Stainless Steel

# STORAGE SYSTEMS

## LOCK OPTIONS

### Built-In Combination Locks



Dead Bolt



Spring Latch

### Combination Padlock



### Built-In Key Locks



Dead Bolt



Spring Latch



Dead Bolt  
(with 2 keys, 4 keys, or keyed alike.)

## VENTILATION OPTIONS



Louvers

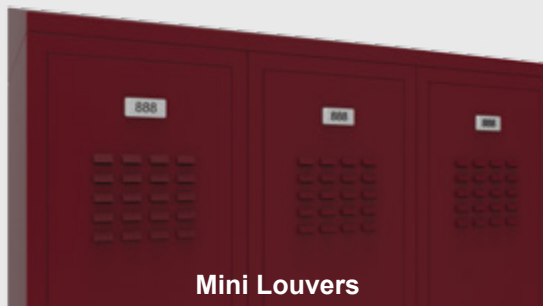

Mini Louvers



Square Vent

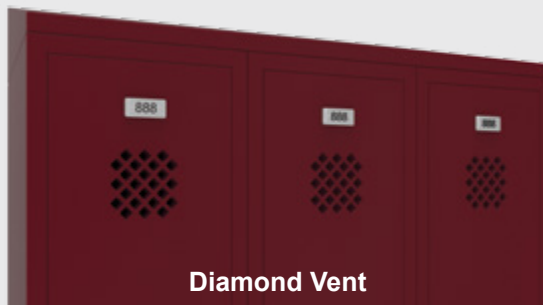

Diamond Vent

# STORAGE SYSTEMS

## Standard Series Locker Size Selections

W x D	One Tier				Two Tier		Three Tier		Four Tier		Five Tier	Six Tier	2 Person
	36" H	48" H	60" H	72" H	60" H	72" H	60" H	72" H	60" H	72" H	60" H	72" H	72" H
12" x 12"	•	•	•	•	•	•	•	•	•	•	•	•	
12" x 15"	•	•	•	•	•	•	•	•	•	•	•	•	
12" x 18"	•	•	•	•	•	•	•	•	•	•	•	•	
15" x 15"			•	•	•	•	•	•			•	•	•
15" x 18"			•	•	•	•	•	•			•	•	•
18" x 18"			•	•	•	•	•	•				•	•

All heights are measured from flat top to bottom of locker. 6" legs available on all Standard Series Lockers (add 6" to all heights above)

## Athletic Series Locker Size Selections

W x D	One Tier		Two Tier		Three Tier		Four Tier		Five Tier	Six Tier
	60" H	72" H	60" H	72" H	60" H	72" H	60" H	72" H	60" H	72" H
12" x 12"	•	•	•	•	•	•	•	•	•	•
12" x 15"	•	•	•	•	•	•	•	•	•	•
12" x 18"	•	•	•	•	•	•	•	•	•	•
15" x 15"	•	•	•	•	•	•	•	•	•	•
15" x 18"	•	•	•	•	•	•	•	•	•	•
18" x 18"	•	•	•							
18" x 21"	•	•	•							
18" x 24"	•	•	•							
24" x 18"	•	•	•							
24" x 21"	•	•	•							
24" x 24"	•	•	•							

All heights are measured from flat top to bottom of locker. 6" legs available on all Athletic Series Lockers (add 6" to all heights above)

# STORAGE SYSTEMS

## Professional Series Locker Size Selections

W x D	One Tier
	72" H
24" x 18"	•
24" x 21"	•
24" x 24"	•
33" x 18"	•
33" x 21"	•
33" x 24"	•

## Continuous Slope Tops Size Selections

72" W (Std)	
D	H
12"	5"
15"	6"
18"	7"
21"	8"
24"	9"

## Z-Bases

72" W x 4" H Front Base	
<i>End / Splice Depth</i>	12"
	15"
	18"
	21"
	24"
<i>Field cut front base as necessary.</i>	

## Trim for Recessed Lockers

L / R Side Trim	
W	H
3"	63" 75"
Top Trim: 74" W x 3" H	
Splice: 2" W x 3" H	

## Fillers

W	H	
6"	60" 66" 72" 78"	
	12"	60" 66" 72" 78"

## Front & Closed Ends

Available W x D Combinations		
W	D	Size <i>W x D x H</i>
12"	12"	
15"	15"	
18"	18"	
24"	21" 24"	
6" H (Std)		

TA-50 locker standard size 42"W x 24"D x 78"H. Custom sizes available.



- Mirrors & Shelves
- Grab Bars
- Hand Dryers
- Towel Dispensers
- Custom Accessories

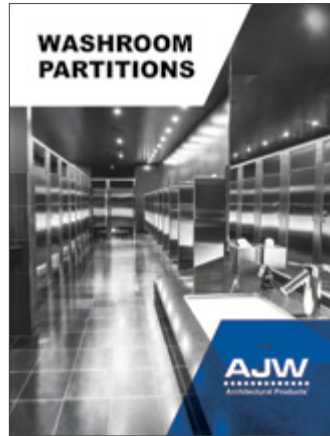

- Solid Plastic Partitions
- Stainless Steel Partitions
- Baked Enamel Partitions
- Phenolic Black Core Partitions
- Plastic Laminate Partitions

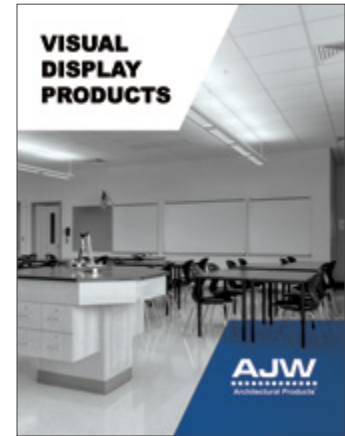

- Markerboards
- Tackboards
- Sliders
- Combination Boards
- Glass Markerboards



Volume 1

509 Temple Hill Road  
New Windsor, NY 12553-5532

**Phone** (845) 562-3332

**Fax** (845) 562-3391

[www.ajw.com](http://www.ajw.com)



**Trigger Lift**

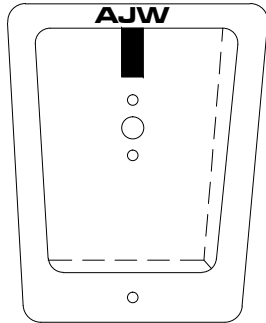

20 ga. deep drawn stainless steel cup, able to accommodate locks. 14 ga. stainless steel lifting trigger. Padlock eye to accommodate 5/16" diameter padlock shackle. Three point latch mechanism, engaging the frame at (3) points on doors greater than 42" in height; (2) engaging points on all other doors.

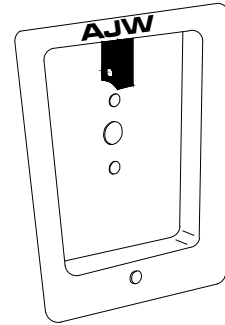

**Single Point**

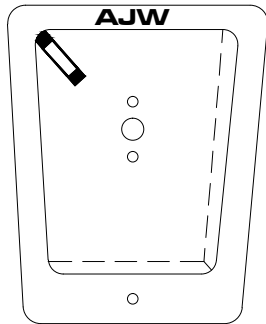

20 ga. deep drawn stainless steel cup, able to accommodate locks. 11 ga. steel hook with padlock hasp welded to door frame. Padlock hasp protrudes through stainless steel cup.

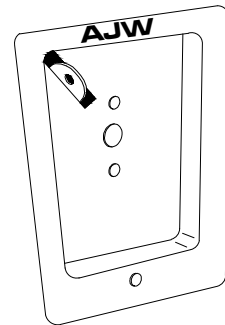

**Security**



3-point turn-handle latching

Engages at frame top, bottom and center side of door, with 3/8" diameter lock rods. 3/16" turn-handle welded to 11 ga. lock plate keeper; welded to center side of frame.

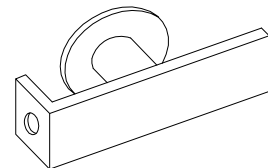

## Bench Tops

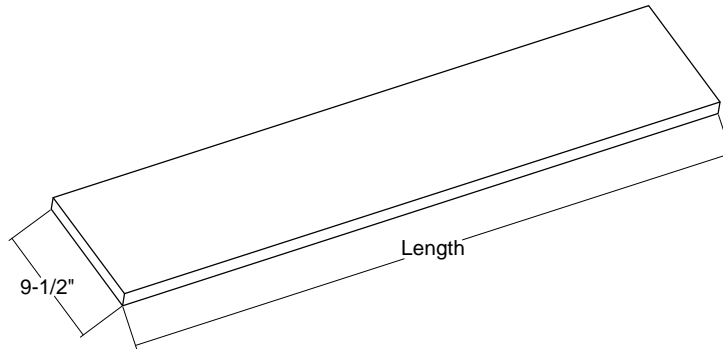

- 1" thick HDPE, or 1 1/4" thick mixed hardwood (finished with (2) coats of clear lacquer).
- 9 1/2" width standard; custom sizes available.

## Pedestals

### Steel

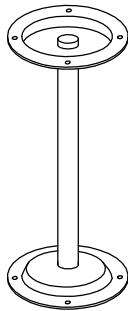

Pedestal fabricated of 1-1/2" diameter steel tubing with 10 ga. steel flanges welded to each end. 16-1/4" high; powder coated to match the lockers.

### Stainless Steel

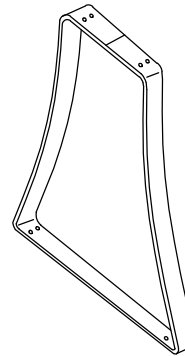

Pedestal fabricated of 2" wide, 16 ga. brushed stainless steel formed into the shape of a trapezoid. 14" long bottom with (2) mounting holes. 16-1/4" high. (4) holes for fastening on top flange.

## Athletic Series Lockers

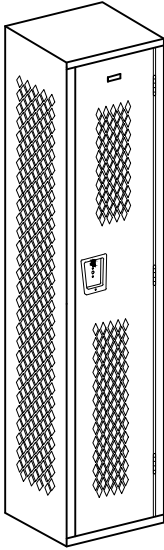

ONE TIER

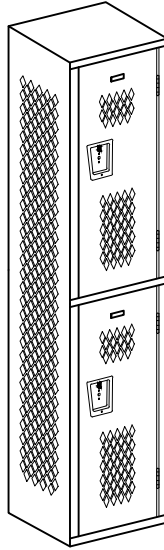

TWO TIER

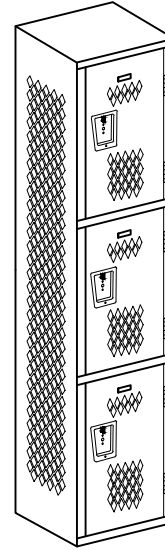

THREE TIER

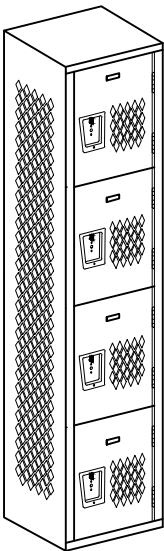

FOUR TIER

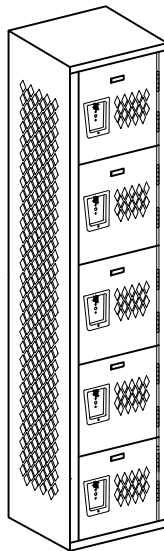

FIVE TIER

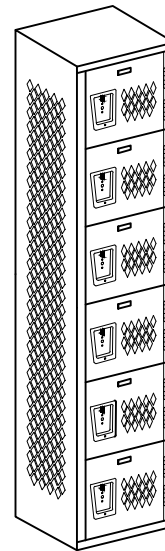

SIX TIER

### Specifications

- **Body:** Backs constructed of mild cold rolled 18 ga. commercial grade steel. Bottom, sides, top, and shelves constructed of 16 ga. commercial grade steel. Bolt spacing shall not exceed 9" off center.
- **Door:** Cold rolled 14 ga. commercial grade steel. Channel shaped on lock and hinge side with angle formations across the top and bottom. Each door shall have a polished aluminum number plate riveted to the face of the door with ½" high black numerals.
- **Door Frame:** Cold rolled 16 ga. commercial grade steel. Channel shaped, with vertical sides having an additional flange to act as a continuous door strike.
- **Finish:** Commercial grade steel cleaned and treated with a phosphate process. Finished coat baked on, powder coated enamel.
- **Color:** Doors and exposed body parts available in colors from AJW standard color selection.
- **Hinges:** 2" five knuckle hinge pairs: 2 per door (3 pairs on doors 48" or larger), or full length 16 ga. piano hinge, riveted to frame and door.
- **Latch / Handle:** 20 ga. deep drawn stainless steel cup, able to accommodate locks. 14 ga. stainless steel lifting trigger. Padlock eye to accommodate 5/16" diameter padlock shackle. Three point latch mechanism, engaging the frame at (3) points on doors greater than 42" in height; (2) engaging points on all other doors. Rubber silencer attached to frame at each latch hook location. Single Point Latch available -- 11 ga. Steel hook with padlock hasp welded to door frame. Padlock hasp protrudes through stainless steel cup.
- **Interior:** Shelves included on all lockers 48"H and up. Two wall hooks and one ceiling hook included on all lockers. Coat rod included on all lockers 18" D.
- **Assembly:** All locker components assembled with rivets (nuts and bolts available upon request). All welded construction as a single unit available (shipped pre-assembled).

**Tops**

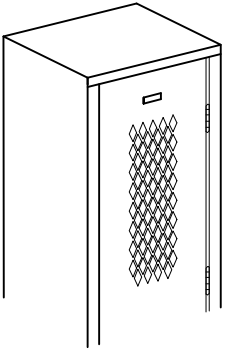

**Flat Top**

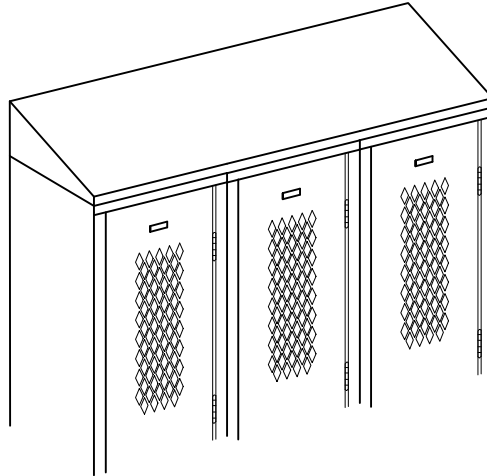

**Continuous Slope**

18 Ga. commercial grade steel, powder coated to match locker color. Continuous slope tops up to 72" in length. (Longer lengths connected with slip joints at splice locations.)

**Bases**

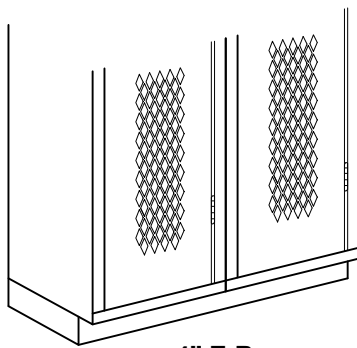

**4" Z-Base**

Z-Bases: 14 Ga. commercial grade steel

6" Legs: 16 Ga. commercial grade steel

Closed Front End: 18 Ga. commercial grade steel

All powder Coated to match locker color.

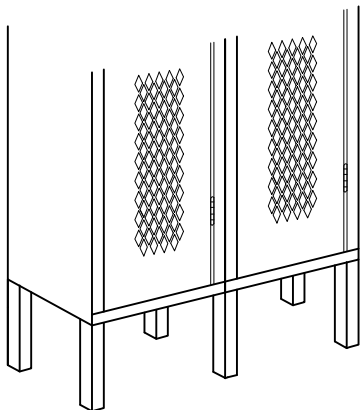

**6" Legs**

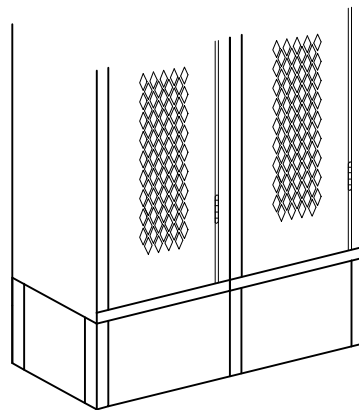

**Closed Front End**



**Trim - (Recessed Lockers Only)**

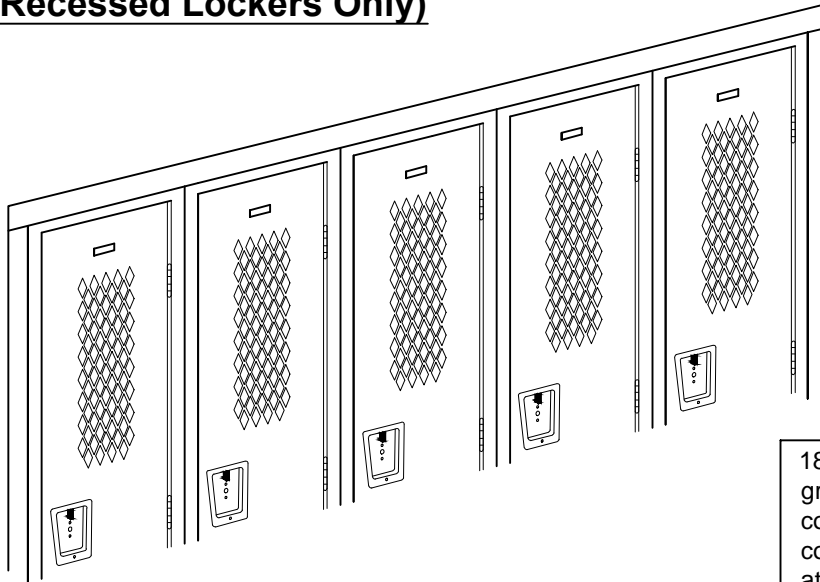

18 Ga. commercial grade steel trim, powder coated to match locker color. Trim face attached to lockers with concealed clips and endcaps.

**Fillers - Vertical**

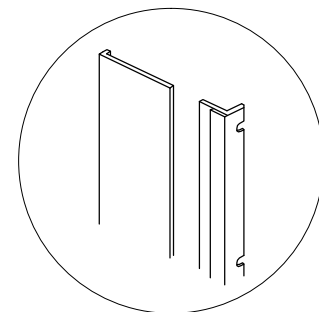
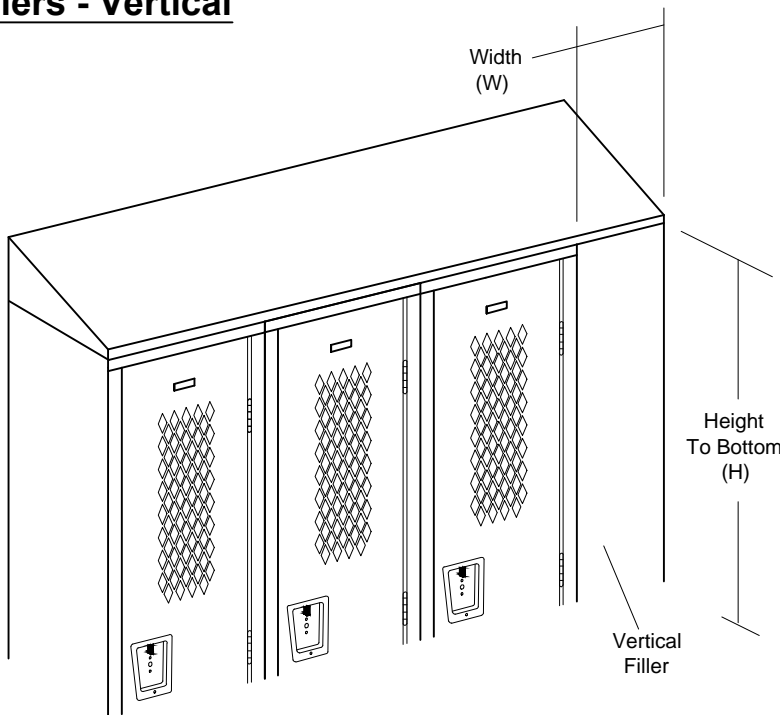

Slip Joint Detail

20 Ga. commercial grade steel, powder coated to match locker color. Fillers formed into an angle and connected with slip joints to create a smooth finish.

**Single Prong Hook**

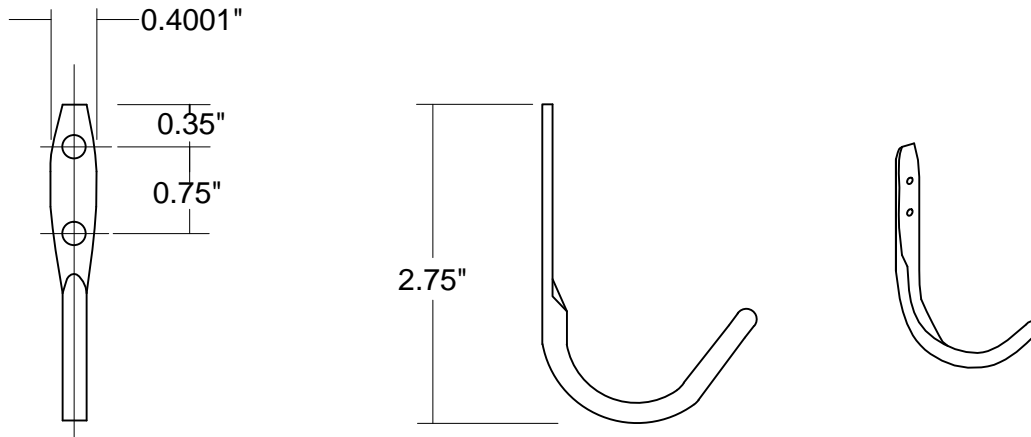

**Double Prong Hook**

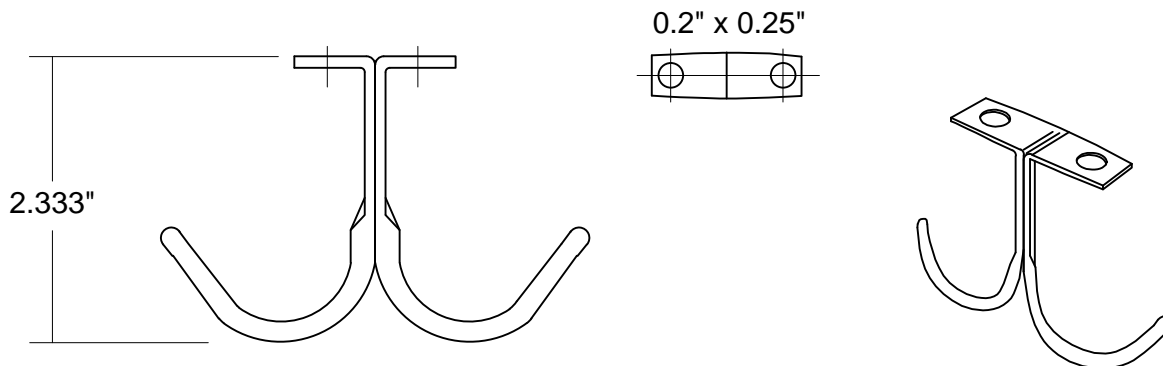

**Coat Rod & Hook**

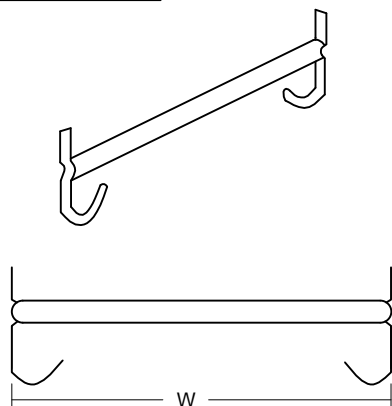

**Number Plate**

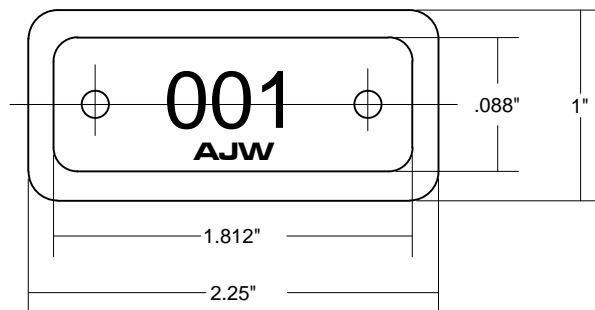

## Standard Series

(W x D)	One Tier				Two Tier		Three Tier		Four Tier		Five Tier	Six Tier	2 Person
	36" H	48" H	60" H	72" H	60" H	72" H	60" H	72" H	60" H	72" H	60" H	72" H	72" H
12" x 12"	•	•	•	•	•	•	•	•	•	•	•	•	
12" x 15"	•	•	•	•	•	•	•	•	•	•	•	•	
12" x 18"	•	•	•	•	•	•	•	•	•	•	•	•	
15" x 15"			•	•	•	•	•	•			•	•	•
15" x 18"			•	•	•	•	•	•			•	•	•
18" x 18"			•	•	•	•	•	•			•	•	•

All heights are measured from flat top to flat bottom of locker. 6" legs available on all Standard Series lockers (add 6" to all heights above).

## Athletic Series

(W x D)	One Tier		Two Tier		Three Tier		Four Tier		Five Tier	Six Tier
	60" H	72" H	60" H	72" H	60" H	72" H	60" H	72" H	60" H	72" H
12" x 12"	•	•	•	•	•	•	•	•	•	•
12" x 15"	•	•	•	•	•	•	•	•	•	•
12" x 18"	•	•	•	•	•	•	•	•	•	•
15" x 15"	•	•	•	•	•	•	•	•	•	•
15" x 18"	•	•	•	•	•	•	•	•	•	•
18" x 18"	•	•	•	•						
18" x 21"	•	•								
18" x 24"	•	•								
24" x 18"	•	•	•	•						
24" x 21"	•	•	•	•						
24" x 24"	•	•	•	•						

All heights are measured from flat top to flat bottom of locker. 6" legs available on all Athletic Series lockers (add 6" to all heights above).

## Professional Series

(W x D)	One Tier
	72" H
24" x 18"	•
24" x 21"	•
24" x 24"	•
33" x 18"	•
33" x 21"	•
33" x 24"	•

## Continuous Slope Tops

72" W (Std)	
D	H
12"	5"
15"	6"
18"	7"
21"	8"
24"	9"

## Z-Bases

72" W x 4" H Front Base	
End / Splice Depth	12"
	15"
	18"
	21"
	24"
<i>Field cut front base as necessary.</i>	

## Front & Closed Ends

Available W x D Combinations		
W	D	Size W x D x H
12"	12"	
15"	15"	
18"	18"	
24"	21"	
	24"	
6" H (Std)		

## Trim for Recessed Lockers

L / R Side Trim	
W	H
3"	63"
	75"
Top Trim	
74" W x 3" H	
Splice	
2" W x 3" H	

## Fillers

W	H
6"	60"
	66"
	72"
	78"
12"	60"
	66"
	72"
	78"

## Standard Series Lockers

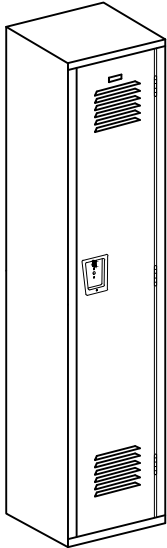

ONE TIER

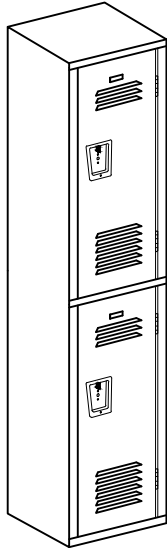

TWO TIER

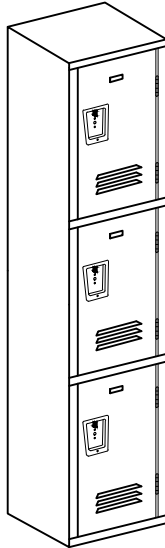

THREE TIER

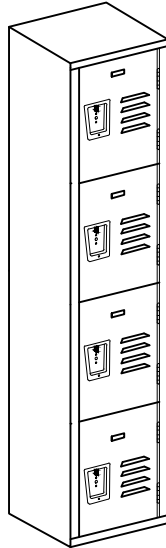

FOUR TIER

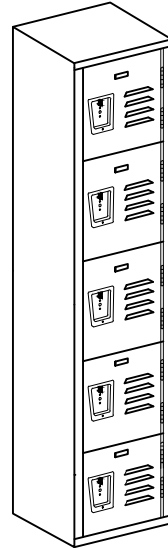

FIVE TIER

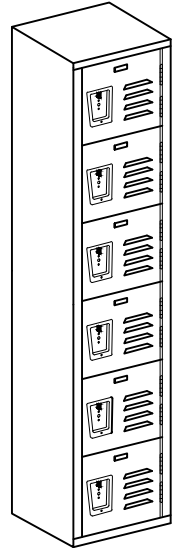

SIX TIER

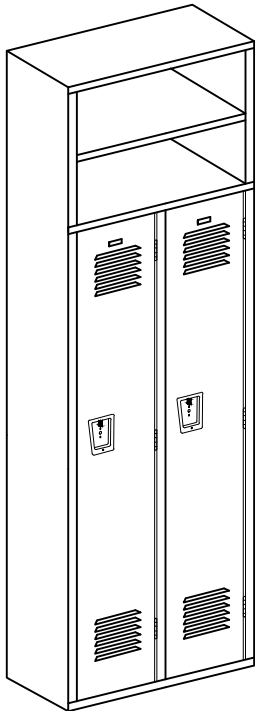

TWO PERSON

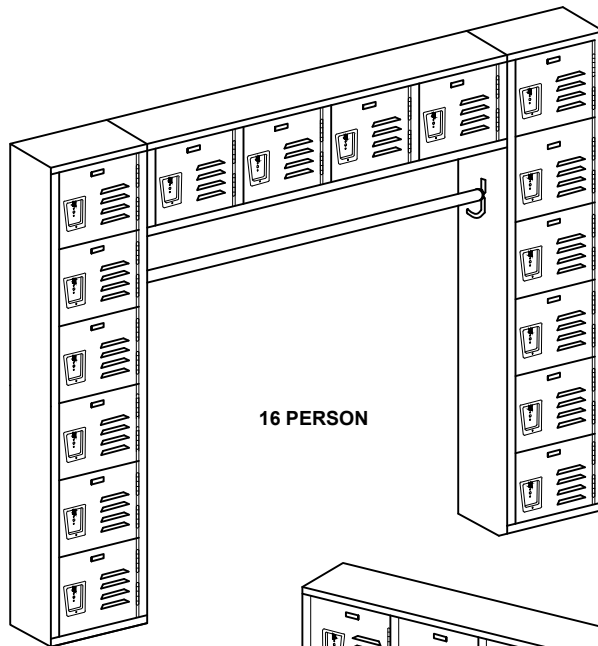

16 PERSON

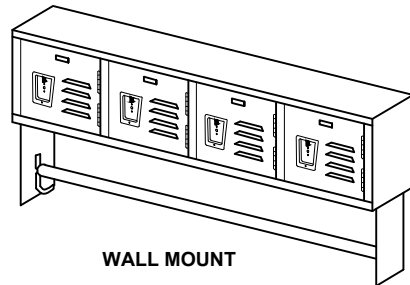

WALL MOUNT

### Specifications

- **Body:** Entire unit (bottom, sides, top, back, and shelves) constructed of mild cold rolled 24 ga. commercial grade steel. Bolt spacing shall not exceed 9" on center.
- **Door:** Cold rolled 16 ga. commercial grade steel. Channel shaped on lock and hinge side with angle formations across the top and bottom. Each door shall have a polished aluminum number plate riveted to the face of the door with ½" high black numerals. Optional ventilation styles available. (14 ga. non-ventilated commercial grade steel door available).
- **Door Frame:** Cold rolled 16 ga. commercial grade steel. Channel shaped, with vertical sides having an additional flange to act as a continuous door strike.
- **Finish:** Commercial grade steel cleaned and treated with a phosphate process. Finished coat baked on, powder coated enamel.
- **Color:** Doors and exposed body parts available in colors from AJW standard color selection.
- **Hinges:** 2" five knuckle hinge pairs: 2 per door (3 pairs on doors 48" or larger), or full length 16 ga. piano hinge, riveted to frame and door.
- **Latch / Handle:** 20 ga. deep drawn stainless steel cup, able to accommodate locks. 14 ga. stainless steel lifting trigger. Padlock eye to accommodate 5/16" diameter padlock shackle. Three point latch mechanism, engaging the frame at (3) points on doors greater than 42" in height; (2) engaging points on all other doors. Rubber silencer attached to frame at each latch hook location. Single Point Latch available -- 11 ga. Steel hook with padlock hasp welded to door frame. Padlock hasp protrudes through stainless steel cup.
- **Interior:** Shelves included on all lockers 48"H and up. Two wall hooks and one ceiling hook included on all lockers. Coat rod included on all lockers 18" D.
- **Assembly:** All locker components assembled with rivets (nuts and bolts available upon request). All welded construction as a single unit available (shipped pre-assembled).

**Note: Difference between knock down and welded assembly is that welded assembly is comprised of a 14 ga. door, 18 ga. back, and 16 ga. for all other parts.**



**Tops**

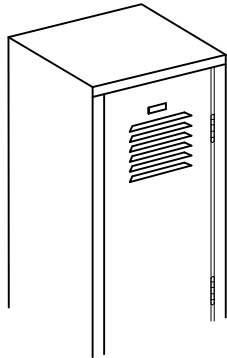

**Flat Top**

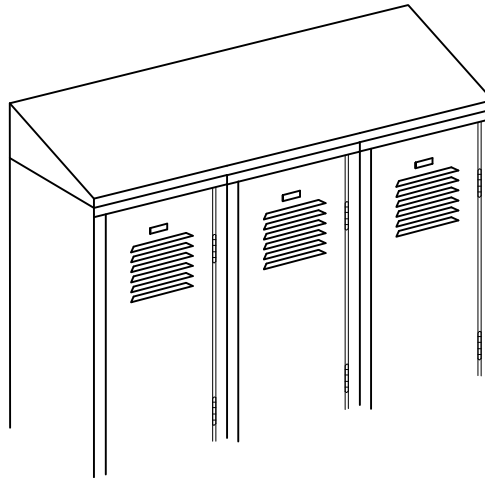

**Continuous Slope**

18 Ga. commercial grade steel, powder coated to match locker color. Continuous slope tops up to 72" in length. (Longer lengths connected with slip joints at splice locations). Degree of slope is 1/3 of locker depth.

**Bases**

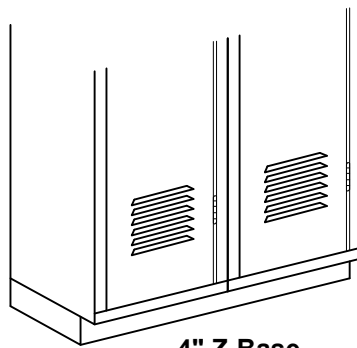

**4" Z-Base**

Z-Bases: 14 Ga. commercial grade steel  
 6" Legs: 16 Ga. commercial grade steel  
 Closed Front End: 18 Ga. commercial grade steel.  
 All powder coated to match locker color.

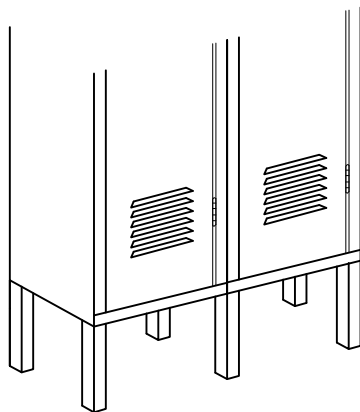

**6" Legs**

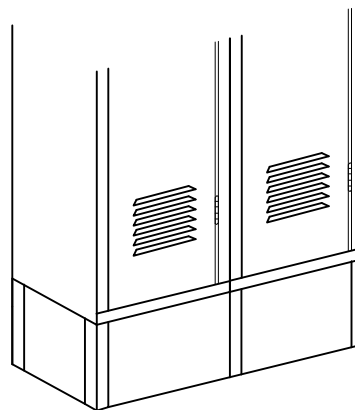

**Closed Front End**

**Trim - (Recessed Lockers Only)**

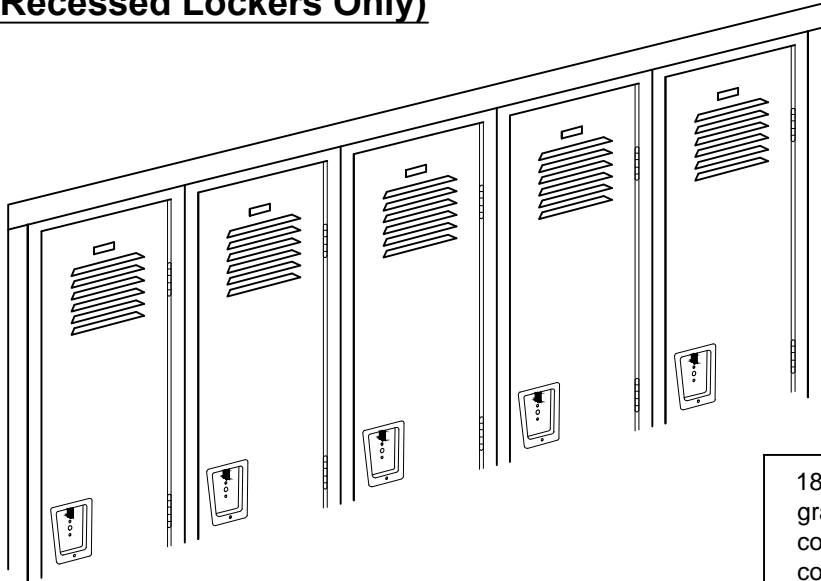

18 Ga. commercial grade steel, trim powder coated to match locker color. Trim face attached to lockers with concealed clips and endcaps.

**Fillers - Vertical**

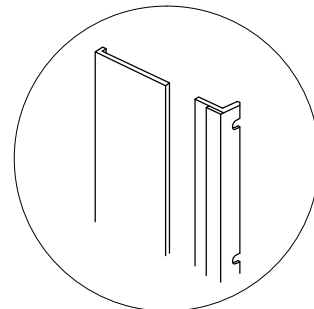
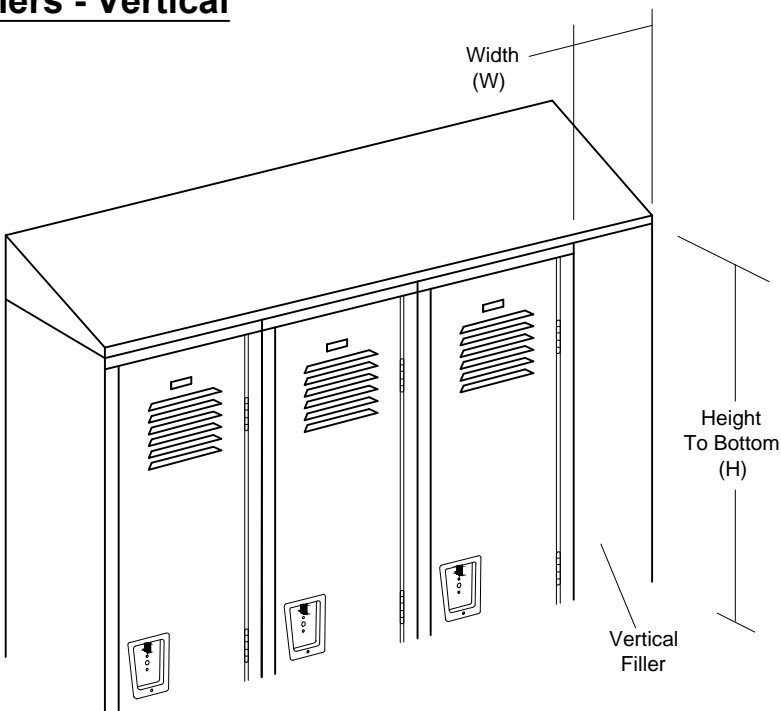

Slip Joint Detail

20 Ga. commercial grade, steel powder coated to match locker color. Fillers formed into an angle and connected with slip joints to create a smooth finish.

Ventilation Options

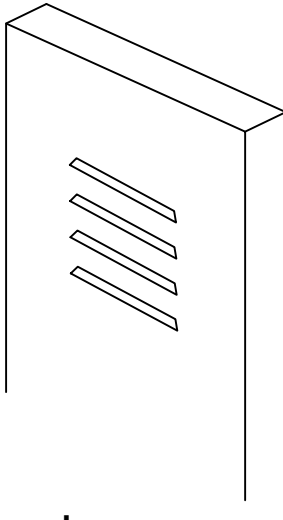

**Louvers**

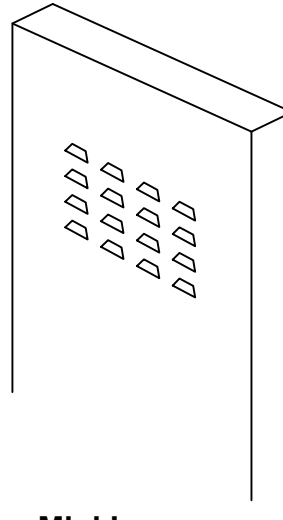

**Mini Louvers**

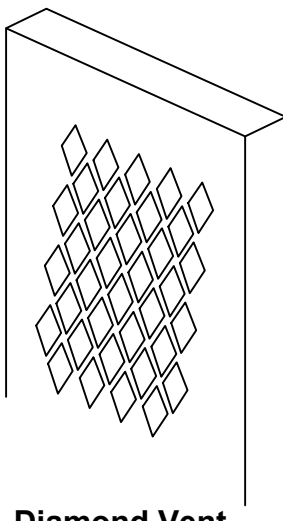

**Diamond Vent**

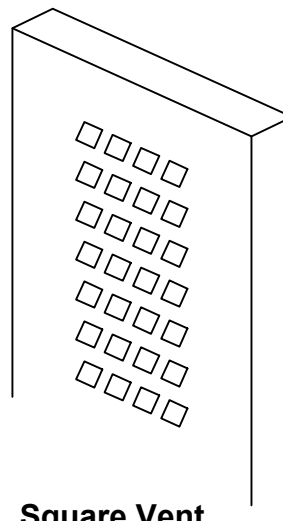

**Square Vent**

**Single Prong Hook**

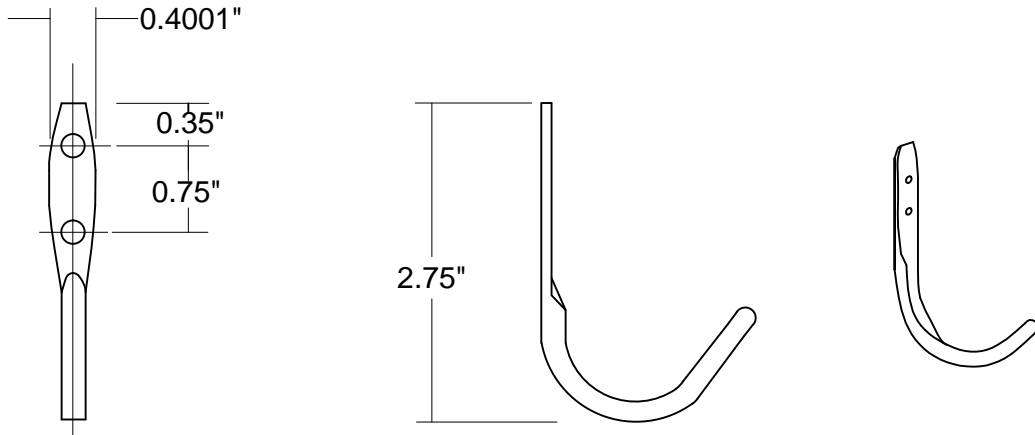

**Double Prong Hook**

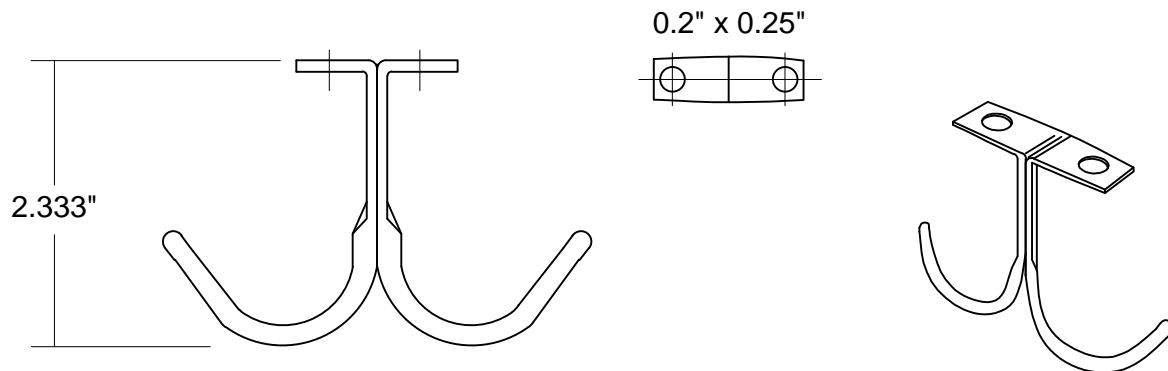

**Coat Rod & Hook**

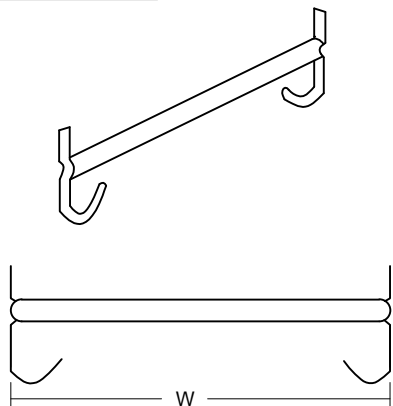

**Number Plate**

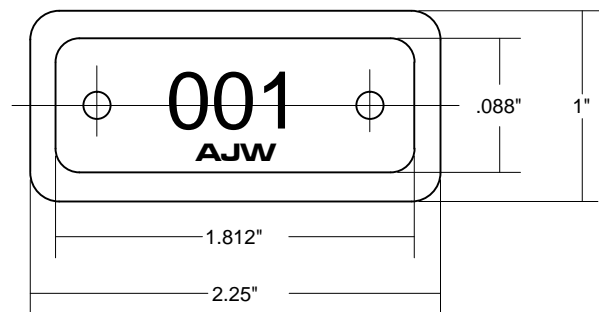

## Standard Series

(W x D)	One Tier				Two Tier		Three Tier		Four Tier		Five Tier	Six Tier	2 Person
	36" H	48" H	60" H	72" H	60" H	72" H	60" H	72" H	60" H	72" H	60" H	72" H	72" H
12" x 12"	•	•	•	•	•	•	•	•	•	•	•	•	
12" x 15"	•	•	•	•	•	•	•	•	•	•	•	•	
12" x 18"	•	•	•	•	•	•	•	•	•	•	•	•	
15" x 15"			•	•	•	•	•	•			•	•	•
15" x 18"			•	•	•	•	•	•			•	•	•
18" x 18"			•	•	•	•	•	•			•	•	•

All heights are measured from flat top to flat bottom of locker. 6" legs available on all Standard Series lockers (add 6" to all heights above).

## Athletic Series

(W x D)	One Tier		Two Tier		Three Tier		Four Tier		Five Tier	Six Tier
	60" H	72" H	60" H	72" H	60" H	72" H	60" H	72" H	60" H	72" H
12" x 12"	•	•	•	•	•	•	•	•	•	•
12" x 15"	•	•	•	•	•	•	•	•	•	•
12" x 18"	•	•	•	•	•	•	•	•	•	•
15" x 15"	•	•	•	•	•	•	•	•	•	•
15" x 18"	•	•	•	•	•	•	•	•	•	•
18" x 18"	•	•	•	•						
18" x 21"	•	•								
18" x 24"	•	•								
24" x 18"	•	•	•	•						
24" x 21"	•	•	•	•						
24" x 24"	•	•	•	•						

All heights are measured from flat top to flat bottom of locker. 6" legs available on all Athletic Series lockers (add 6" to all heights above).

## Professional Series

(W x D)	One Tier
	72" H
24" x 18"	•
24" x 21"	•
24" x 24"	•
33" x 18"	•
33" x 21"	•
33" x 24"	•

## Continuous Slope Tops

72" W (Std)	
D	H
12"	5"
15"	6"
18"	7"
21"	8"
24"	9"

## Z-Bases

72" W x 4" H Front Base	
End / Splice Depth	12"
	15"
	18"
	21"
24"	
<i>Field cut front base as necessary.</i>	

## Front & Closed Ends

Available W x D Combinations		
W	D	Size W x D x H
12"	12"	
15"	15"	
18"	18"	
24"	21"	
	24"	
6" H (Std)		

## Trim for Recessed Lockers

L / R Side Trim	
W	H
3"	63"
	75"
Top Trim	
74" W x 3" H	
Splice	
2" W x 3" H	

## Fillers

W	H
6"	60"
	66"
	72"
	78"
12"	60"
	66"
	72"
	78"



## SECTION 10 5113

### METAL LOCKERS

This section includes editing notes to assist the user in editing the section to suit project requirements. These notes are included as hidden text, and can be revealed or hidden by one of the following methods:

Microsoft Word 2010: Display the FILE tab on the ribbon, click OPTIONS, then on left menu click on DISPLAY. Under ALWAYS SHOW THESE select or deselect HIDDEN TEXT.

Microsoft Word 2007: Click the OFFICE button, select WORD OPTIONS, select DISPLAY, then select or deselect the HIDDEN TEXT option.

Corel WordPerfect: From the pull-down menus select VIEW, then select or deselect the HIDDEN TEXT option.

This master specification section has been prepared by AJW Architectural Products for use in the preparation of a project specification section covering metal lockers and locker benches.

This specification is a part of the SpexPlus™ system, which comprises a full architectural master specification that can be used to specify all project requirements.

Other guide specifications are available from AJW covering the following products:

Section 10 1100 - Visual Display Units  
Section 10 2114 - Stainless Steel Toilet Compartments  
Section 10 2116 - Solid Plastic Toilet Compartments  
Section 10 2813 - Toilet Accessories

The following should be noted in using this specification:

Hypertext links to specific websites are included after manufacturer names and names of organizations whose standards are referenced within the text, to assist in product selection and further research. Hypertext links are contained in parenthesis and shown in blue, e.g.:

([www.spexplus.net](http://www.spexplus.net))

Optional text requiring a selection by the user is enclosed within brackets, e.g.: "Section [09 0000.] [\_\_\_\_.]"

Items requiring user input are enclosed within brackets, e.g.: "Section [\_\_\_\_ - \_\_\_\_]."

Optional paragraphs are separated by an "OR" statement, e.g.:

\*\*\*\* OR \*\*\*\*

Sustainable requirements are included for projects requiring LEED certification, and are included as green text. For additional information on LEED, visit the U.S. Green Building Council website at [www.usgbc.org](http://www.usgbc.org).

For assistance on the use of the products in this section, contact AJW Architectural Products by calling 845-562-3332, email at [specs@ajw.com](mailto:specs@ajw.com), or visit their website at [www.ajw.com](http://www.ajw.com).

For assistance with obtaining or using the SpexPlus™ Master Specification System contact SpexPlus by calling 1-888-877-SPEX (1-888-877-7739), by email at [chaney@spexplus.net](mailto:chaney@spexplus.net), or visit our website at [www.spexplus.net](http://www.spexplus.net).

## PART 1 GENERAL

### 1.1 SUMMARY

Edit the following paragraphs to include only those items specified in this section.

- A. Section Includes:
  - 1. Metal locker units with hinged doors.
  - 2. Metal [bases] [tops] [and] [filler panels].
  - 3. Locker benches.

Coordinate the following paragraphs with other sections in the project manual.

- B. Related Sections:
  - 1. Division 01: Administrative, procedural, and temporary work requirements.

## 1.2 SUBMITTALS

Limiting submittals to only those actually required helps to minimize liability arising from the review of submittals. Minimize submittals on smaller, less complex projects.

Include the following for submission of shop drawings, product data, and samples for the Architect's review.

- A. Submittals for Review:
  - 1. Shop Drawings: Include dimensioned layout, elevations, trim, closures, and accessories.
  - 2. Product Data: Manufacturer's descriptive data for each locker type.
  - 3. Samples: [Color chips showing full range of available colors.] [3 x 3] [\_\_ x \_\_] inch paint samples in specified colors.]

Include the following for submission of sustainable design submittals.

- B. Sustainable Design Submittals:
  - 1. Regional Materials: Certify distance between manufacturer and project and between manufacturer and extraction or harvest point in miles.

## 1.3 QUALITY ASSURANCE

The following paragraph specifies a minimum level of experience required of the parties performing the work of this section. Retain if required, and edit to suit project requirements.

- A. Installer Qualifications: Minimum [2] [\_\_] years [documented] experience in work of this Section.

Edit the following to suit project requirements.

- B. Accessibility: Conform to [applicable accessibility code.] [\_\_\_\_.]

## PART 2 PRODUCTS

### 2.1 MANUFACTURERS

- A. Contract Documents are based on products by AJW Architectural Products, 509 Temple Hill Road, New Windsor, NY 12553, 845-562-3332, [www.ajw.com](http://www.ajw.com), [specs@ajw.com](mailto:specs@ajw.com).

Edit the following to indicate whether or not substitutions will be permitted for the products in this section.

- B. Substitutions: [Under provisions of Division 01.] [Not permitted.]

### 2.2 MATERIALS

- A. Steel Sheet:
  - 1. Prime grade mild cold rolled, free from surface imperfections, capable of receiving powder coated finish.

### 2.3 COMPONENTS

Include the following for Standard Series lockers. Edit to suit project requirements.

- A. Lockers:
1. Model: Standard Series.
  2. Assembly: [Knocked down, field assembled with rivets.] [Welded into single unit and shipped pre-assembled.]
  3. Configuration: [Single tier.] [Double tier.] [Triple tier.] [Four tier.] [Five tier.] [Six tier.] [Two person.] [16 person.] [Wall mount.]
  4. Ventilation type: [Standard louver.] [Diamond Vent.] [Mini Louver.] [Square Vent.]
  5. Size: [ ] inches wide x [ ] inches deep x [ ] inches high.
  6. Mounting: [Recessed.] [Surface mounted.] [Free standing.]
  7. Construction:
    - a. Door frame:
      - 1) 16 gauge steel, channel shaped; vertical members provided with additional flange for continuous door strike.
      - 2) 16 gauge cross frame members, channel shaped, including intermediate cross frames on double and triple tier lockers.

Standard locker doors are 16 gauge but may be up to 14 gauge if required.

- b. Doors: [Knocked down; 16 gauge steel] [Welded; 14 gauge steel] with ventilation louvers, channel shaped on lock and hinge sides, with angle formations across top and bottom.

Standard locker bodies are 24 gauge but may be up to 16 gauge if required. Bottoms may be 14 gauge steel for knock-down lockers.

- c. Bottoms, tops, sides, backs, and shelves: [Knocked down; 24 gauge steel,] [Welded; locker back of 18 gauge steel, other parts of 16 gauge steel,] bolted at maximum 9 inches on center.
8. Hinges: [2 inch high, five knuckle] [One piece, 16 gauge, full length continuous] type, riveted to door and frame.
9. Handles: One piece, 20 gauge deep drawn stainless steel cup designed to accommodate locks.
10. Latching device: Trigger lift type.
  - a. 14 gauge steel, attached to latching channel, with 9/32 inch hole for use with standard padlock, enclosed with molded thermal formed plastic cover.
  - b. Latch hooks engage frame at three points on doors over 42 inches high, and two points on doors under 42 inches high.
  - c. Rubber silencers secured in frame at each latch hook.
  - d. Positive automatic type; locker door may be locked when open, then closed without unlocking.

\*\*\*\* OR \*\*\*\*

11. Latching device: Single point type.
  - a. Frame hook of 11 gauge steel, welded to door frame, opposite of hinged side.
  - b. Padlock hasp protruding through stainless steel recessed handle.
12. Interior equipment:
  - a. Shelves: Steel shelf on lockers over 48 inches high.
  - b. Hooks: Two single prong wall hooks and one double prong ceiling hook.

Lockers 18 inches in depth receive coat rod. Coat rods are optional on lockers less than 18 inches in depth.

- c. Coat rod: One per locker.
13. Number plates: Polished aluminum with 1/2 inch high black numerals, riveted to door face.

\*\*\*\* OR \*\*\*\*

Include the following for Standard EX Collection lockers. Edit to suit project requirements.

B. Lockers:

1. Model: Standard EX Series.
2. Assembly: [Knocked down, field assembled with rivets.] [Welded into single unit and shipped pre-assembled.]
3. Configuration: [Single tier.] [Double tier.] [Triple tier.]
4. Size: [ ] inches wide x [ ] inches deep x [ ] inches high.
5. Mounting: [Recessed.] [Surface mounted.] [Free standing.]
6. Construction:
  - a. Door frame:
    - 1) 16 gauge steel, channel shaped; vertical members provided with additional flange for continuous door strike.
    - 2) 16 gauge cross frame members, channel shaped, channel shaped, including intermediate cross frames on double and triple tier lockers.

Standard locker doors are 16 gauge but may be up to 14 gauge if required.

b. Doors:

- 1) 14 gauge steel, non-ventilated, solid construction, channel shaped on both lock and hinge sides, with angle formations across top and bottom.
- 2) Full height 16 gauge reinforcement channel on single, double, and triple tier lockers:

Standard locker bodies are 24 gauge but may be up to 16 gauge if required. Bottoms may be 14 gauge steel for knock-down lockers.

c. Bottoms, tops, sides, backs, and shelves: [Knocked down; 24 gauge steel,] [Welded; locker back of 18 gauge steel, other parts of 16 gauge steel,] bolted at maximum 9 inches on center.

7. Hinges: [2 inch high, five knuckle] [One piece, 16 gauge, full length continuous] type, riveted to door and frame.
8. Handles: One piece, 20 gauge deep drawn stainless steel cup designed to accommodate locks.
9. Latching device: Single point type.
  - a. Frame hook of 11 gauge steel, welded to door frame, opposite of hinged side.
  - b. Padlock hasp protruding through stainless steel recessed handle.
10. Interior equipment:
  - a. Shelves: Steel shelf on lockers over 48 inches high.
  - b. Hooks: Two single prong wall hooks and one double prong ceiling hook.

Lockers 18 inches in depth receive coat rod. Coat rods are optional on lockers less than 18 inches in depth.

c. Coat rod: One per locker.

11. Number plate: Polished aluminum with 1/2 inch high black numerals, riveted to door face.

\*\*\*\* OR \*\*\*\*

Include the following for Athletic Collection lockers. Edit to suit project requirements.

C. Lockers:

1. Model: Athletic Series.
2. Assembly: [Knocked down, field assembled with rivets.] [Welded into single unit and shipped pre-assembled.]
3. Configuration: [Single tier.] [Double tier.] [Triple tier.] [Four tier.] [Five tier.] [Six tier.]
4. Ventilation type: Diamond shaped perforation, quantity and pattern to ensure maximum ventilation while maintaining structural integrity.
5. Size: [ ] inches wide x [ ] inches deep x [ ] inches high.
6. Mounting: [Recessed.] [Surface mounted.] [Free standing.]
7. Construction:
  - a. Door frame:
    - 1) 16 gauge steel, channel shaped; vertical members provided with additional flange

- for continuous door strike.
- 2) 16 gauge cross frame members, channel shaped, including intermediate cross frames on double and triple tier lockers.
- b. Doors: 14 gauge steel with diamond shaped perforation, channel shaped on lock and hinge sides, with angle formations across top and bottom.
- c. Bottoms, tops, sides, backs, and shelves: 18 gauge steel backs; other parts of 16 gauge steel, bolted at maximum 9 inches on center.
- 8. Hinges: [2 inch high, five knuckle] [One piece, 16 gauge, full length continuous] type, riveted to door and frame.
- 9. Handles: One piece, 20 gauge deep drawn stainless steel cup designed to accommodate locks.
- 10. Latching device: Trigger lift type.
  - a. 14 gauge steel, attached to latching channel, with 9/32 inch hole for use with standard padlock, enclosed with molded thermal formed plastic cover.
  - b. Latch hooks engage frame at three points on doors over 42 inches high, and two points on doors under 42 inches high.
  - c. Rubber silencers secured in frame at each latch hook.
  - d. Positive automatic type; locker door may be locked when open, then closed without unlocking.

\*\*\*\* OR \*\*\*\*

- 11. Latching device: Single point type.
  - a. Frame hook of 11 gauge steel, welded to door frame, opposite of hinged side.
  - b. Padlock hasp protruding through stainless steel recessed handle.
- 12. Interior equipment:

Lockers minimum 48 inches high have shelves.

- a. Shelves: 16 gauge steel shelf.
- b. Hooks: Three single prong wall hooks and one double prong ceiling hook.

Lockers 18 inches in depth receive coat rod. Coat rods are optional on lockers less than 18 inches in depth.

- c. Coat rod: One per locker.
- d. Number plate: Polished aluminum with 1/2 inch high black numerals, riveted to door face.

\*\*\*\* OR \*\*\*\*

Include the following for Professional Collection lockers. Edit to suit project requirements.

- D. Lockers:
  - 1. Model: Professional Series.
  - 2. Assembly: [Knocked down, field assembled with rivets.] [Welded into single unit and shipped pre-assembled.]
  - 3. Configuration: Single locker with open front.
  - 4. Ventilation type: Diamond perforated sides.
  - 5. Size: [ ] inches wide x [ ] inches deep x 72 inches high.
  - 6. Mounting: [Recessed.] [Surface mounted.] [Free standing.]
  - 7. Construction:
    - a. Locker frames: 16 gauge steel.
    - b. Backs: 18 gauge steel.
    - c. Bottoms, tops, sides, and shelves: 16 gauge steel, bolted at maximum 9 inches on center.

Include the following for an optional security box.

:

- 8. Security box:
  - a. 14 gauge lockable door with 16 gauge side panel.
  - b. Door attached to welded frame with 2 inch high, five knuckle hinge, secured with

- c. aluminum rivets.
- c. 16 gauge steel door frame formed to channel shape; vertical members provided with additional flange for continuous door strike.
- d. Recessed single point latch handle.

Include the following for an optional foot locker.

:

- 9. Foot locker:
    - a. Continuously hinged top with rubber bumpers at contact points.
    - b. Steel strengthened with two reinforcement channels welded to bottom of seat. Two side seat supports fastened to side panels and inserted in support tab on front locker panel.
    - c. Mini louvers.
    - d. Single point latch with padlock strike plate.
  - 10. Number plate: Polished aluminum with 1/2 inch high black numerals, riveted to door face.
- E. Accessories:
- 1. Locks: [Built-in combination locks.] [Combination pad locks.] [Built-in key locks; provide [two] [ ] keys per lock and [six] [ ] master keys.]

Include the following if filler panels required.

- 2. Filler panels: 20 gauge steel.

Include the following if perimeter trim is required.

- 3. Perimeter trim: 18 gauge steel, 3 inches wide, attached with concealed clips.

Include the following paragraph for metal bases.

- 4. Bases: 14 gauge steel, 4 inches high, Z-shaped, front [and end panels].

Include the following paragraph for sloped tops.

- 5. Sloped tops: 18 gauge steel, [continuous] type [with end closures].

Include the following for prefabricated locker benches.

- F. Locker Benches:
- 1. Size: 9-1/2 inches wide x [ ] feet long.
  - 2. Tops: [1-1/4 thick hardwood with rounded edges.] [1 inch thick plastic with 1/4 inch radius edges.]
  - 3. Supports: [Steel tubing with welded-on 10 gauge stainless steel top and bottom flanges, 16-1/4 inches high, finished to match lockers.] [2 inch width, 16 gauge brushed stainless steel, 16-1/4 inches high formed to trapezoidal shape, with four mounting holes in top for fastening to bench and four holes on bottom for fastening to floor.]

## 2.4 FINISHES

- A. Steel:
- 1. Power wash and phosphate treat.
  - 2. Apply hybrid epoxy/polyester powder coating, electrostatically applied and baked.
  - 3. Color: [ ] [To be selected from manufacturer's full color range].
- B. Wood: Two coats clear lacquer.

## PART 3 EXECUTION

### 3.1 INSTALLATION



- A. Install in accordance with manufacturer's instructions and approved Shop Drawings.

Include the following paragraph when lockers are set on a wood, concrete, or masonry base.

- B. Set on prepared locker base.
- C. Set plumb, level, and aligned.
- D. Attach lockers to supporting construction with anchors best suited to substrate conditions.
- E. Bolt adjacent locker units together to provide rigid installation.
- F. Install [filler panels] [sloped tops] [and] [bases].

### 3.2 ADJUSTING

- A. Adjust doors and latches to operate correctly.
- B. Touch up minor scratches and abrasions to match factory finish.

END OF SECTION

## Care, Cleaning, and Maintenance Instructions – Metal Lockers

Ensure that the area in which the lockers are installed has adequate ventilation. All metal lockers should be properly ventilated to reduce humidity and moisture, especially in locker rooms that are in close proximity to swimming pools.

Periodically open and close the locker doors to determine any issues with latches, hinges, or locking mechanisms. If the door does not latch properly, adjust the door jamb / frame hooks as necessary with a pair of pliers.

Tighten connections on any loose components, such as coat hooks or nuts/bolts.

Lubrication of the door hinges, frame hooks, and lock bar is recommended every couple of months. WD40, or an equivalent industrial lubricant, is acceptable.

The interior / exterior of the locker may be cleaned with a mild, non-abrasive cleaning solution and warm water. Immediately after cleaning, thoroughly dry surface with a soft cloth.

These cleaners should **not** be used under any circumstance:

- Abrasive cleaners, which can harm and degrade the surface over time.
- Acidic cleaners
- Alkaline Cleaners
- Cleaners containing hydrogen peroxide, xylene, methylene chloride, muriatic acid, or acetone.

Nicks and small scratches may be remedied with touch up paint (contact AJW for additional information)

## Standard Locker Colors



Grey (0010)



Steel Grey (0011)



Ivory (0012)



Cement Grey (0013)



Taupe (0014)



Fossil Green (0015)



Teal (0016)



Hunter Green (0017)



Colonial Blue (0018)



Dusk Blue (0019)



Marine Blue (0020)



Yellow (0021)



Orange (0022)



Stop Red (0023)



Ruby Red (0024)



Burgundy (0025)



Royal Blue (0026)



Plum Purple (0027)



Winter White (0028)



Jet Black (0029)

**Note: Color charts are printed approximations--actual colors may vary. Please contact AJW to request a sample.**

## Standard Series

(W x D)	One Tier				Two Tier		Three Tier		Four Tier		Five Tier	Six Tier	2 Person
	36" H	48" H	60" H	72" H	60" H	72" H	60" H	72" H	60" H	72" H	60" H	72" H	72" H
12" x 12"	•	•	•	•	•	•	•	•	•	•	•	•	
12" x 15"	•	•	•	•	•	•	•	•	•	•	•	•	
12" x 18"	•	•	•	•	•	•	•	•	•	•	•	•	
15" x 15"			•	•	•	•	•	•			•	•	•
15" x 18"			•	•	•	•	•	•			•	•	•
18" x 18"			•	•	•	•	•	•			•	•	•

All heights are measured from flat top to flat bottom of locker. 6" legs available on all Standard Series lockers (add 6" to all heights above).

## Athletic Series

(W x D)	One Tier		Two Tier		Three Tier		Four Tier		Five Tier	Six Tier
	60" H	72" H	60" H	72" H	60" H	72" H	60" H	72" H	60" H	72" H
12" x 12"	•	•	•	•	•	•	•	•	•	•
12" x 15"	•	•	•	•	•	•	•	•	•	•
12" x 18"	•	•	•	•	•	•	•	•	•	•
15" x 15"	•	•	•	•	•	•	•	•	•	•
15" x 18"	•	•	•	•	•	•	•	•	•	•
18" x 18"	•	•	•	•						
18" x 21"	•	•								
18" x 24"	•	•								
24" x 18"	•	•	•	•						
24" x 21"	•	•	•	•						
24" x 24"	•	•	•	•						

All heights are measured from flat top to flat bottom of locker. 6" legs available on all Athletic Series lockers (add 6" to all heights above).

## Professional Series

(W x D)	One Tier
	72" H
24" x 18"	•
24" x 21"	•
24" x 24"	•
33" x 18"	•
33" x 21"	•
33" x 24"	•

## Continuous Slope Tops

72" W (Std)	
D	H
12"	5"
15"	6"
18"	7"
21"	8"
24"	9"

## Z-Bases

72" W x 4" H Front Base	
End / Splice Depth	12"
	15"
	18"
	21"
24"	
<i>Field cut front base as necessary.</i>	

## Front & Closed Ends

Available W x D Combinations		
W	D	Size W x D x H
12"	12"	
15"	15"	
18"	18"	
24"	21"	
	24"	
6" H (Std)		

## Trim for Recessed Lockers

L / R Side Trim	
W	H
3"	63"
	75"
Top Trim	
74" W x 3" H	
Splice	
2" W x 3" H	

## Fillers

W	H
6"	60"
	66"
	72"
	78"
12"	60"
	66"
	72"
	78"



## Warranty – Metal Lockers

Subject to the terms set out in this warranty, AJW guarantees the below listed products to be free from manufacturing defects in material and workmanship for **the specified periods below**, all from the date of shipment.

- Knock down lockers: **(2) Years**
- Welded lockers: **Lifetime of the Building**
- Built-in Combination Locks: **(10) Years**
- Combination Padlocks: **(5) Years**
- Built-in Key Locks: **(5) Years**
- HDPE Bench Tops: **(25) Years**
- Hardwood Bench Tops: **(2) Years**

This warranty is for material supplied by AJW only, and only applies to the original installation of the material, installed in accordance with AJW's written installation instructions and drawings. AJW's recommendations for proper handling, storage, cleaning, and maintenance must be followed for this warranty to be valid.

This warranty excludes defects in the locker caused by: vandalism, improper usage, improper installation, neglect, or failure in the structure of the building. Damage to, or fading of paint as a result of exposure to excessive moisture, humidity, or corrosive chemicals is also excluded under this warranty. Regular maintenance is required for this locker warranty to be valid.

If the material is found to be defective in workmanship or materials within the specified time frame listed above, from the date of shipment, AJW will replace all affected material free of charge. AJW will not be responsible for any expenses including, but not limited to the removal, installation costs, or any other costs associated with the repair or replacement of the material.

The replacement or repair of defective material as stated in this warranty shall constitute the sole remedy of the buyer and the sole liability of AJW under this warranty. AJW shall not be liable for any incidental, consequential or indirect damages caused by the failure or defect in the material supplied, or any delay in the replacement or repair of warranty items.

Warranty claims must be made during the warranty period, and communicated to AJW by contacting AJW Architectural Products at 509 Temple Hill Road – New Windsor, NY 12553 - Phone: 845-562-3332.