

date
projectname

attn
from
fax
email
phone

7/22/20
REDEVELOPMENT OF EAST HARTFORD HOUSING
AUTHORITY
SIOBHAN AYALA
SIOBHAN AYALA
siobhan.ayala@doncoinc.com



U126 Soap Dispenser

Revision 11/14

JOB #:

ITEM #:

QUANTITY:

MOUNTING	HANDING	TYPE	SIZE	OTHER



SPECIFICATIONS

Soap Tank: Fabricated of #20 ga stainless steel, #4 satin finish, fully welded one-piece construction.

Valve: All purpose antibacterial soap valve cylinder, black molded plastic push style valve that takes less than 5 lbs of force and one hand to operate complies with barrier free guidelines when mounted at proper height.

Viewer: Clear plastic window allows a constant fluid level check.

Concealed Mounting Plate: Fabricated of heavy gauge stainless steel.

Filler Cap: Fabricated of stainless steel, hinged to allow easy servicing, secured with special key that creates a vandal resistant dispenser.

Overall Size: 4 3/4"W x 8 1/4"H x 3 3/4"D (wall to valve)
121mm x 210mm x 95mm

Capacity: 40 oz.

Recommend type soaps without chloric solutions for proper operation.

INSTALLATION

Provide an area on mounting surface at desired or specified location. Secure concealed mounting plate to wall surface with proper fasteners. Slide dispenser down over mounting plate and secure by means of set screw located inside tank. Fill unit with proper soap. Close lid and secure with special key. Test valve for proper operation.

*It is not recommended to mount any soap dispenser on mirrors

**For best performance, use pre-mixed low concentrate solutions. Dispensers should have periodic maintenance performed to insure the life dispenser. Rinse out globe and valve with warm water to avoid sludge buildup.

Preventative Maintenance: Each dispenser should be flushed out aprx. Every 30 days with warm water to prevent valve from clogging with old soap. Do not use abrasive cleaners to clean dispenser.

NOTES



U1511EA Series

Low Profile Hands Free Dryer with
Universal Voltage

Revision 11/14

JOB #:

ITEM #:

QUANTITY:

MOUNTING	HANDING	TYPE	SIZE	OTHER

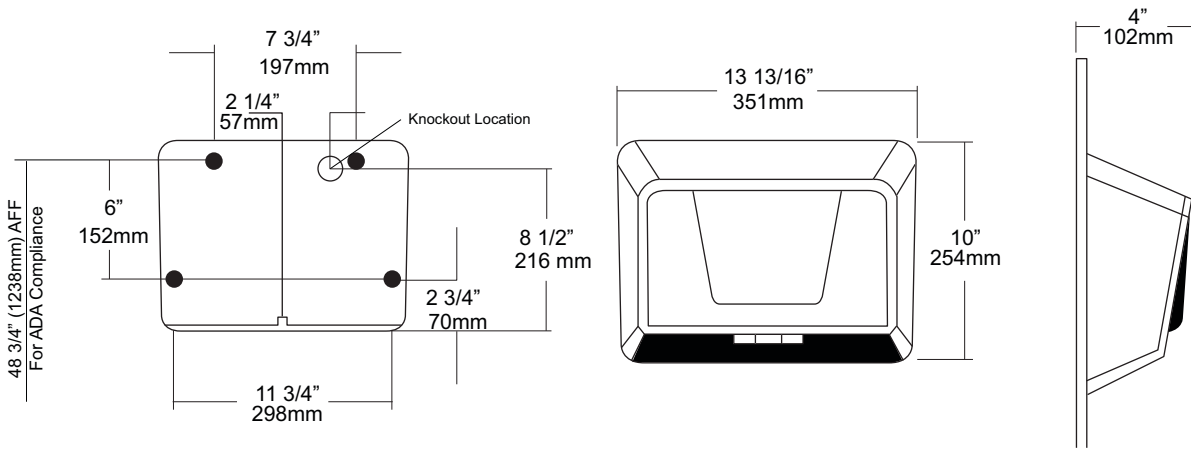

SPECIFICATIONS

Element: Industrial strength coil wound on mica support protected by temperature limit.

Circuitry: Infrared microprocessor control allows multi- voltage application.

Assembly: Dual blower wheel and housing made of engineered thermoplastics powered by thermally protected brush motor. Assembled on a plated steel base plate for maximum strength and durability.

Cover and Finish:

U1511EA: Powder coated (white) formed steel alloy. Cover secured to base with theft resistant screws.

U1511EA-SF: satin stainless steel cover.

Overall Size: 13"W x 10"H x 4"D

Specifications:

Motor: 7500 RPM (Brushed motor)

Sound Level: 73 DB

Volts	Watts	Amps	Frequency
110-120	1800	15	50 hz or 60 hz
208-240	2400	10	50 hz or 60 hz

INSTALLATION

Coordinate installation with architect and contractor avoid interference with pipes, vents etc. Verify mounting height for each application for code compliance. Place template on wall surface and transfer mounting points, Drill holes for securing making sure power source is not be interrupted when base is installed, Remove cover. Unit must be installed by qualified licensed electricians. Properly connect power supply and test dryer for proper operation, Install cover and secure with theft resistant fasteners and test again. (15 second delay from when power is connected to when unit is operational)

NOTES

Formerly Model #: U1511EA



U590
 Sanitary Napkin Disposal with Access
 Panel
 Revision 10/11

JOB #:
ITEM #:
QUANTITY:

MOUNTING	HANDING	TYPE	SIZE	OTHER

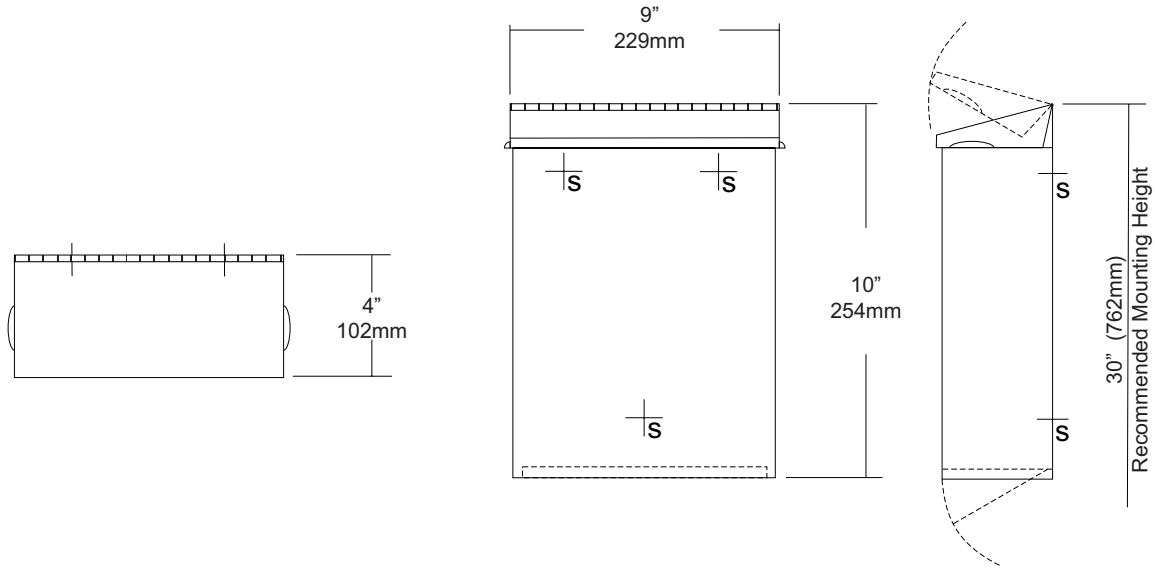

SPECIFICATIONS	INSTALLATION
----------------	--------------

Cabinet Body: Fabricated of #22 ga stainless steel with #4 satin finish. Seamless construction with radius and hemmed edges.

Cabinet Back: Fabricated of Stainless steel welded to cabinet body with key hole mounting points.

Cover: Fabricated of #22 ga stainless steel #4 satin finish with embossed handles on each side and sloped top.

Bottom Panel: #22 ga hinged and locked for removal of contents.

Hinges: Heavy duty, full length, stainless steel piano type hinges.

Lock: Commercial quality keyed like all other AJW cabinets.

Overall Size: 9"W x 10"H x 4"D
229mm x 254mm x 102mm

Capacity: 1.6 gallons (.2 cu ft)

NDL-13-50: Waxed disposable liners. (50 per Case)

Provide an area at desired or specified location. Place unit on surface and transfer mounting points. Drill pilot holes and secure with proper fasteners. Install waxed liner.

NOTES



U650

Folded Towel & Waste Combination Unit

Revision 10/14

JOB #:

ITEM #:

QUANTITY:

MOUNTING	HANDING	TYPE	SIZE	OTHER

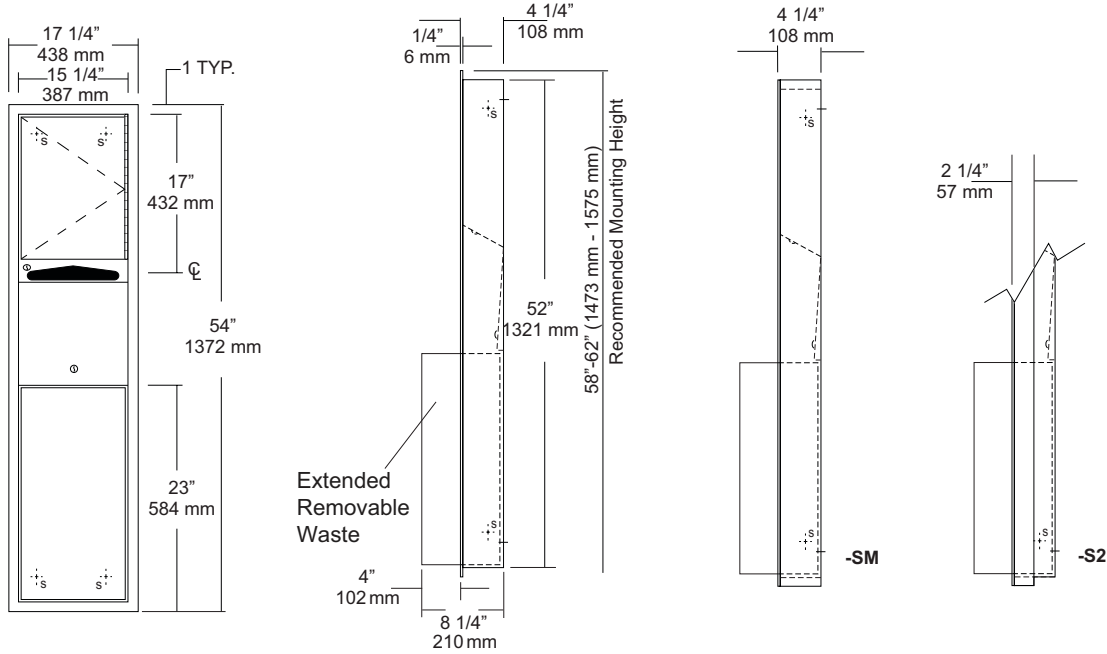

SPECIFICATIONS

Body: Fabricated of #22 ga stainless steel with a #4 satin finish.

Flange: Fabricated of #22 ga stainless steel finished to match cabinet with 1/4" returns. (No miters or welds)

Cabinet Back: Fabricated of stainless steel formed for rigidity with multiple welds to cabinet body.

Cabinet Door: Fabricated of #22 ga stainless steel with #4 satin finish.

Towel Dispenser: Fabricated of #22 ga stainless steel with hemmed edges to prevent injury and towel tearing.

Removable Waste: Fabricated of #22 ga stainless steel #4 satin finish with all leading edges to have a radius. Unit is secured in place by a bottom bracket guide and top lock.

Hinge: Full length, heavy duty, stainless steel piano type hinge.

Locks: Pin tumbler commercial quality, keyed like all other AJW cabinets.

Collars: Fabricated of #22 ga stainless steel, finished to match cabinet. (Used when full recessing cannot be accomplished)

Overall Size: 17 1/4"W x 54"H x 8 1/4"D
438mm x 1372mm x 210mm

Wall Opening: 15 3/4"W x 52 1/2"H x 4"D
400mm x 1334mm x 102mm

U650-S2: semi-recessed. with 2" collar, 2" wall opening 51mm

U650-SM: Full surface mounted collar.

Towel Capacity: 600 c-fold or 800 multifold

Waste Capacity: 12 gallons (1.6 cu ft)

Options :

-VL1: Vinyl Liner

INSTALLATION

Coordinate installation with architect and contractor to avoid interference with pipes, vents, etc. Provide a rough wall opening 15 3/4"W x 52 1/2"H. See chart for required wall depth. If collar is required, slide collar over the back before installing into wall. Remove waste from cabinet and mount unit plumb and true in opening with proper fasteners per application. Secure waste in cabinet and load paper towels.

When cleaning cabinet use a non abrasive non-chloric solution and wiped off with the grain of the cabinet.

NOTES



U704 Series

Fixed Tilt Angle Frame Mirror

Revision 11/15

JOB #:

ITEM #:

QUANTITY:

MOUNTING	HANDING	TYPE	SIZE	OTHER

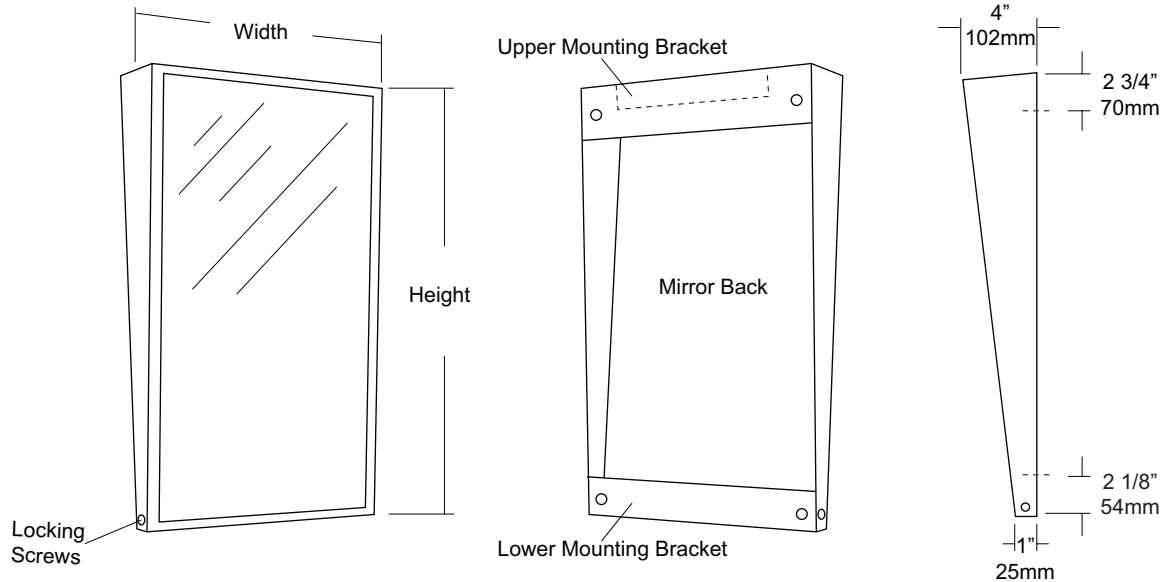

SPECIFICATIONS

Frame: Fabricated of #18 ga stainless steel, #4 satin finish. Stainless steel frame is fabricated with welded mitered corners that are ground and polished smooth. Mirror extends out 4" at top and tapers to 1" at bottom.

Mirror: 1/4" thick type 1 transparent flat type, class 1 - clear glass mirrors. Mirror is coated with silver and sealed with a uniform electrolytic copper plating, along with two coats of paint for added protection. Mirrors are guaranteed against silver spoilage for a period of 15 years. Mirrors conform to ASTM C1036 and ASTM C1503-R8.

Filler: 3/16" thick full size, shock absorbing, water resistant, non-abrasive polyethylene padding protects all concealed mirror surfaces

Brackets: Mounting brackets are fabricated of #20 ga pre-plated, galvanized steel. Lower bracket has two (2) side mounting points that allow frame to be secured to bracket.

Standard Sizes Available (W x H): 16"x24", 16"x30", 18"x24", 18"x30", 18"x36", 24"x30", 24"x36"

Options:

LG: Laminated Glass

LX: Polycarbonate

PM: Plastic Acrylic

T: Tempered Glass

VC: Vinyl Clad (Safety Glass)

8B: #8 Reflective Stainless Steel

*Stainless steel mirrors reflect images in different optic quality than plate glass. There will be a slight distortion which increases proportionately with the mirror size. Therefore, AJW Architectural Products™ cannot be held responsible for quality of image.

** Mirrors are always ordered Width x Height

*** Recommended max size for 8B mirrors: 72" x 47-1/2"

**** Framed mirrors are fabricated to a tolerance of (+/-) 1/8"

***** Mirrors conform to Federal Specifications DD-M-00411b & DD-g-541D

INSTALLATION

Coordinate installation with architect / contractor for specific mounting location and height for each mirror application. Check all state and local codes for installation requirements. Remove hanger brackets and transfer mounting points to wall surface. Secure with proper fasteners for each application. Slide mirror frame over brackets and secure in place. Secure frame to bracket. Fillers are available if mirrors are mounted above and below tile line. (U004 Filler) Filler material will match mirror frame to form a one piece construction.

To meet ADA Code, bottom edge of reflective surface can be no higher than 40" above finished floor. (4.19.6) Full length mirrors may be used for universal application when installed in correct locations.

Abrasive cleaners & chloric solutions should not be used on mirrors. Discoloring or scratching may occur on frame and reflective surface.

NOTES



UB16

Heavy Duty Chrome Coat Hook

Revision 03/11

JOB #:

ITEM #:

QUANTITY:

MOUNTING	HANDING	TYPE	SIZE	OTHER

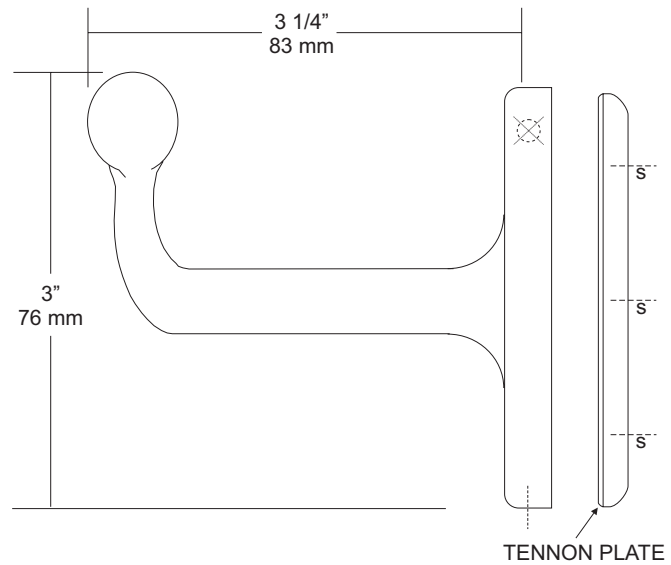
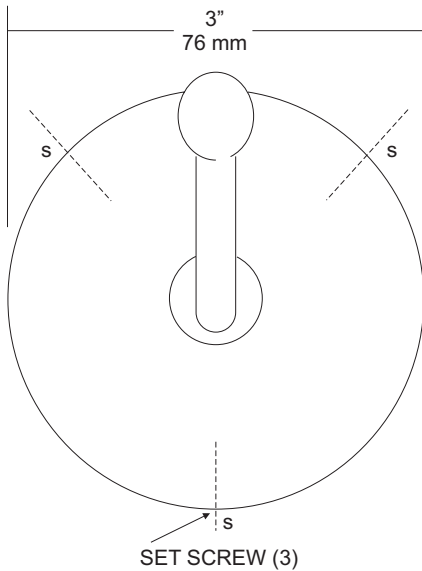

SPECIFICATIONS	INSTALLATION
----------------	--------------

UB Accessories: Fabricated of forged brass with a nickel and copper plating of chrome coating. In compliance with all standard commercial and government standards. Three (3) set screws will secure mounting flange to tenon plate providing a concealed mount.

Overall Size: 3"OD x 3"H x 3 1/4"D

76mm x 76mm x 83mm

Place tenon plate to wall surface and transfer mounting point locations. Drill pilot holes and secure tenon plate with proper fasteners per application. Place hook around tenon plate making sure hook is aligned properly. Secure flange to tenon plate with three (3) set screws.

NOTES



UG3-A

Grab Bars

Revised 03/11

JOB #:

ITEM #:

QUANTITY:

MOUNTING	HANDING	TYPE	SIZE	OTHER



SPECIFICATIONS & INSTALLATION

Tubing: Fabricated of #18 ga stainless steel with a #4 satin finish. Available in 1 1/2" outside diameter. All bends are formed by an automatic mandrel bending process. All bars maintain a constant 1 1/2" offset.

Finish: Standard finish is a #4 satin finish. For a non-slip finish (peened) add suffix X to model number. (Ex. UG3X-A)

Flanges: Snap flanges are fabricated of 3" diameter, 3/8" deep drawn #22 ga stainless steel with #4 satin finish to match tubing. Flanges have dimples that secure over mounting plate.

Strength: Bars with a 1 1/2" offset clearance will support loads in excess of 900lbs when properly installed. Bars with greater offsets will support loads up to 250lbs when properly installed.

Installation: Before installing grab bars, verify with all state and local codes for requirements on bar diameter and type finish. Recommended mounting heights for grab bars are 33" - 36" centerline above finished floor. All mounting of grab bars when possible should have in wall mounting back plates. Find centerline mounting points and place bar on line making sure to be on center. Transfer mounting points (3 per flange) to wall. Drill pilot holes and secure bar with proper anchors per application. Snap cover over mounting plate.

Standard Lengths (Other sizes available upon request): 12", 16", 18", 24", 30", 32", 36", 42", 48", 50", 52", 54", 56"

FLANGE INFORMATION

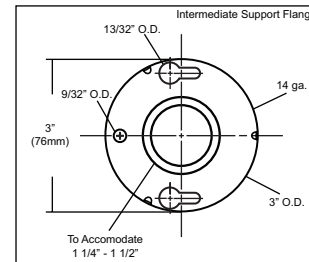
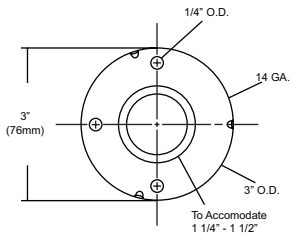
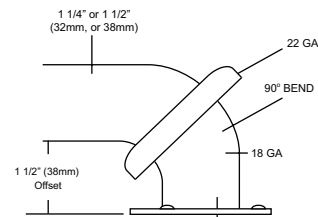

NOTES



UX141-BF

Toilet Tissue Dispenser

Revision 03/11

JOB #:

ITEM #:

QUANTITY:

MOUNTING	HANDING	TYPE	SIZE	OTHER

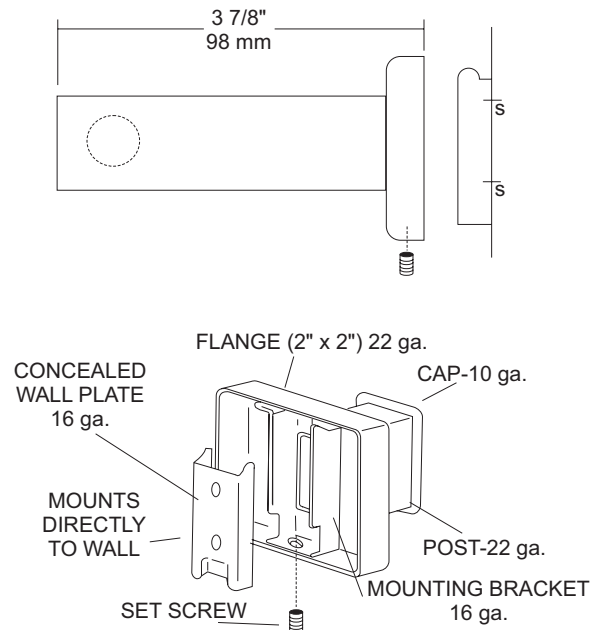
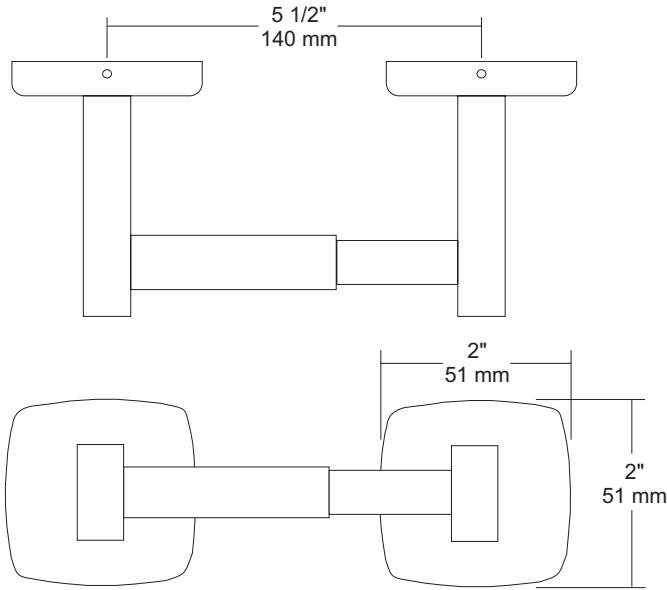

SPECIFICATIONS

UX Accessories: All UX bath accessories series are fabricated of stainless steel with a bright or satin finish. Mounting plates are concealed with a snap-on type plate secured by a set screw.

Flange: 2" x 2" flange #22 ga stainless steel.

Post: #22 ga stainless steel.

Mounting Plate: #16 ga concealed wall plate. Set screw secures mounting plate and flange.

Spindle: Spring loaded, chrome plated plastic.

Optional U007 Theft Resistant Adapter: Prevents spindle from being removed until roll has been depleted.

Overall Size: 7 1/2" W x 2"H x 1 5/8"D

51mm x 51mm x 43mm

UX141-SF: Same as UX141-BF with satin finish

INSTALLATION

Provide an area on wall surface at desired or specified location. Place concealed mounting plate on wall surface and transfer mounting points. Drill pilot holes and secure with proper fasteners. Place snap-on flange over plate and secure with set screw. Centerline space between posts is aprx. 5 1/2"W. Repeat same steps for other post. Place a roll of tissue on spindle and place in posts before securing the covers down securely. If roll spins freely, secure post with set screw. All toilet tissue dispensers must have a non-control delivery to meet ADA code. (4.16)

NOTES