

date
projectname
attn
from
fax
email
phone

4/12/17
Rescue 8
Daniel
jim
804-276-4854
admin@georgewjonesco.com
804-276-7530



U129PC

Vanity Mounted Soap Dispenser

Revision 07/11

JOB #:

ITEM #:

QUANTITY:

MOUNTING	HANDING	TYPE	SIZE	OTHER

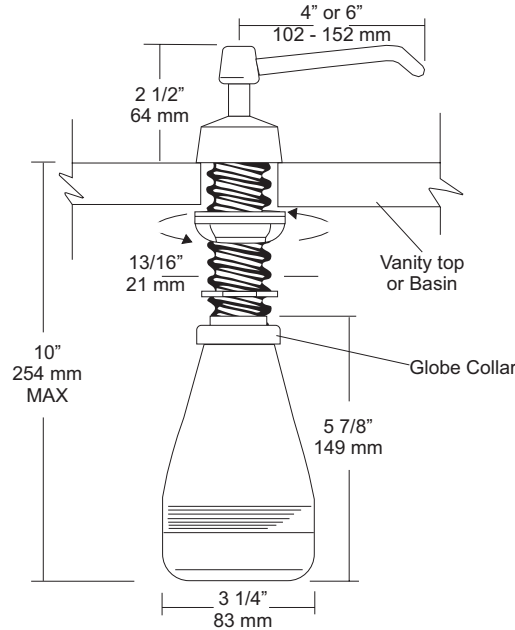

SPECIFICATIONS

Piston & Spout: Highly polished corrosion resistant, stainless steel. Assembly rotates 360 degrees.

Flange & Collar: One piece highly polished chrome on brass.

Valve Assembly: All purpose bellows valve, fabricated of ABS material, with stainless steel return spring.

Shank: Chrome on brass, secured to collar. Special key provided that unlocks collar for servicing.

Globe & Collar: High impact translucent polyethylene.

Capacity: 16 fl oz

U129PCA: Same as U129PC with 6" (152mm) spout.

Recommend type soaps without chloric solutions for proper operation.

***All vanity soap dispensers are designed to be serviced above the counter**

INSTALLATION

Provide a 7/8" - 1" diameter opening in vanity or basin. Insert shank through cut out and secure with supplied washers and wing nut. Connect supply tube with valve making sure notch end is at bottom. Secure globe and collar to shank. Fill globe above counter. Secure upper assembly to shank. Prime dispenser every time unit is serviced.

*It is not recommended to mount any soap dispenser on mirrors

**For best performance, use pre-mixed low concentrate solutions. Dispensers should have periodic maintenance performed to insure the life dispenser. Rinse out globe and valve with warm water to avoid sludge buildup.

Preventative Maintenance: Each dispenser should be flushed out aprx. Every 30 days with warm water to prevent valve from clogging with old soap. Do not use abrasive cleaners to clean dispenser.

NOTES

Formerly Model #: U129-PC



U2324

Uni-Door Towel Dispenser

Revision 03/11

JOB #:

ITEM #:

QUANTITY:

MOUNTING	HANDING	TYPE	SIZE	OTHER

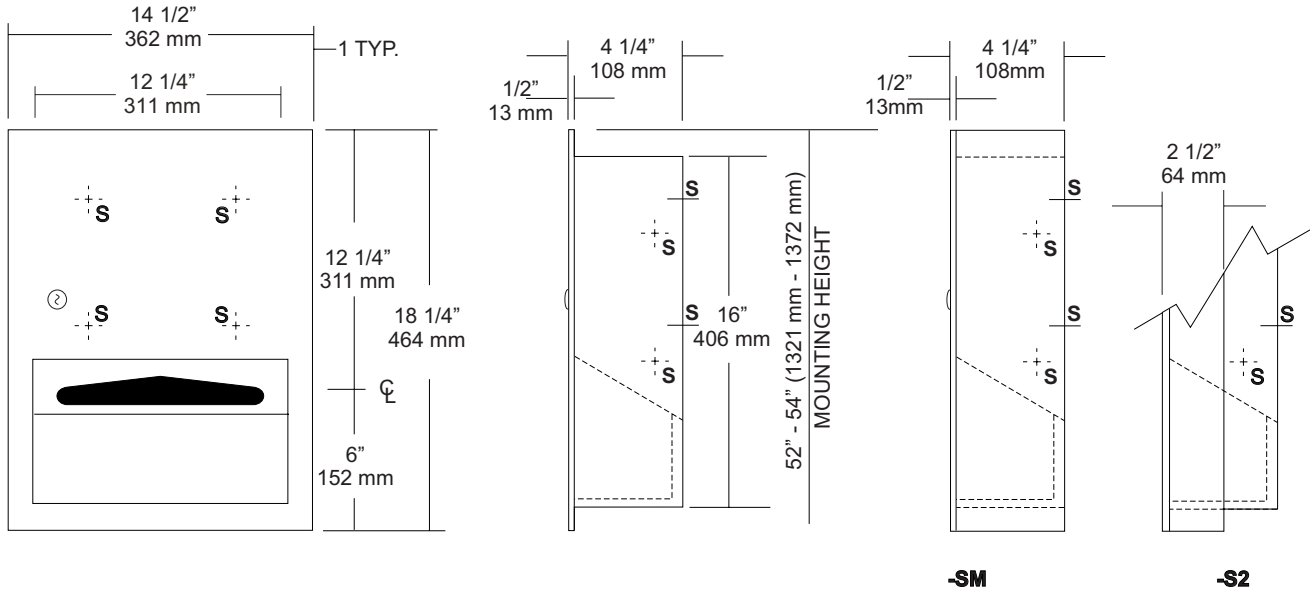

SPECIFICATIONS	INSTALLATION
----------------	--------------

Cabinet Body: Fabricated of #22 ga stainless steel. Face trim is an integral part of body with a #4 satin finish and 1/4" returns to wall surface for rigidity. One piece construction without miters or welds.

Uni-Door: Fabricated of #18 ga stainless steel with a #4 satin finish with 1/2" returns to wall for rigidity. Full length one piece door with 1/2" returns inside cabinet to prevent injury when reaching for towels.

Cabinet Back: Fabricated of #22 ga stainless steel with multiple welds to cabinet body:

Towel Dispensing: Hemmed edges that prevent injury and towel tearing.

Hinges: Heavy duty, full length, stainless steel piano type hinge.

Locks: Commercial quality, pin tumbler keyed alike.

Collars: Fabricated of #22 ga stainless steel finished to match cabinet for surface or recess mounting.

Overall Size: 14 1/2"W x 18 1/4"W x 4 1/4"D
368mm x 464mm x 108mm

Wall Opening: 12 3/4"W x 16 1/2"H x 4"D
324mm x 419mm x 102mm

U2324-S2: 2" semi-recessed collar, 2" wall opening 51mm.

U2324-SM: Full surface mounted collar.

Capacity: 350 c-fold or 475 multifold

Coordinate installation with architect and contractor to avoid interference with pipes vents etc. in wall. Provide a rough wall opening 12 3/4"W x 16 1/2"H. See specification for proper wall depth opening. If collar is required, slip collar over back of unit. Open cabinet and insert into wall opening. Secure with proper fasteners per each application. Fill unit with recommended towels, without overfilling. Make sure towels overlap each other so they will be available each time a towel is removed from dispensing area.

NOTES

MOUNTING	HANDING	TYPE	SIZE	OTHER
----------	---------	------	------	-------

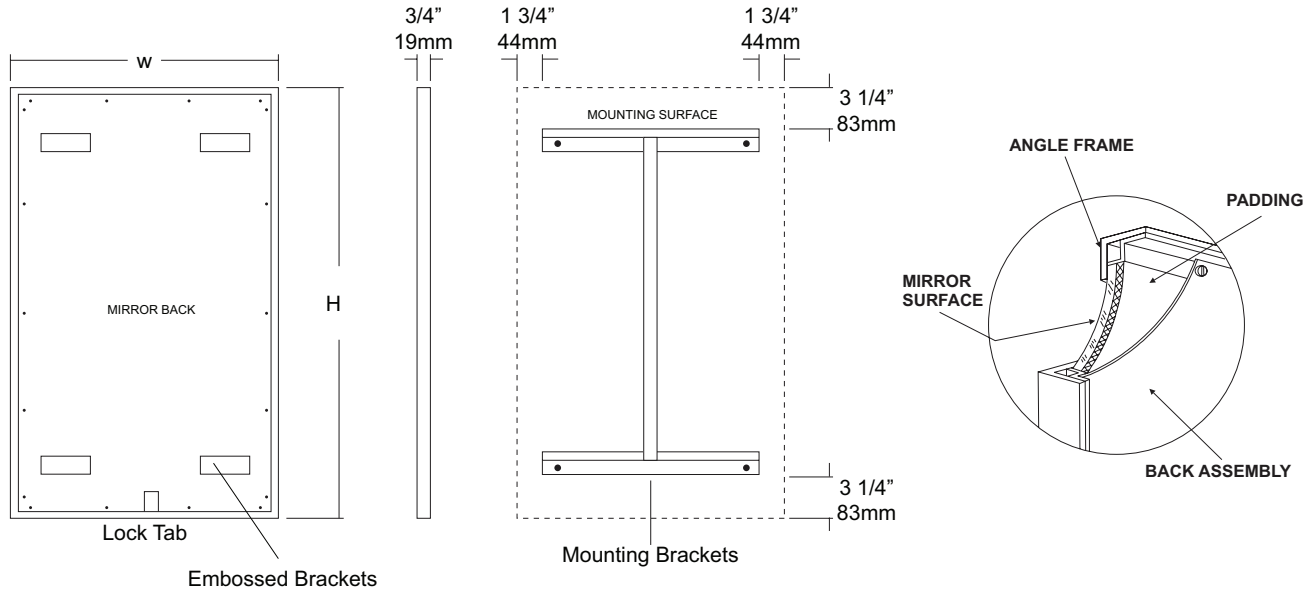

SPECIFICATIONS

Frame: Fabricated of #18 ga stainless steel, #4 satin finish. 3/4" x 3/4" frame with welded mitered corners are ground and polished smooth. #22 ga concealed "Z" channel is spot welded to inner perimeter of frame for reinforcement and greater rigidity.

Mirror: 1/4" thick type 1 transparent flat type, class 1 - clear glass mirrors. Mirror is coated with silver and sealed with a uniform electrolytic copper plating, along with two coats of paint for added protection. Mirrors are guaranteed against silver spoilage for a period of 15 years. Mirrors conform to ASTM C1036 and ASTM C1503-R8.

Filler: 3/16" thick full size, shock absorbing, water resistant, non-abrasive polyethylene padding protects all concealed mirror surfaces.

Back: #20 ga pre-plated galvanized steel, with embossed horizontal louver mounting brackets. Embossed theft resistant pressure activated clip lock device, locks mirror in place to wall hangers. Back is secured to frame with concealed Phillips head screws.

Hangers: Fabricated of #20 ga pre-plated steel galvanized steel with mounting points.

Standard Sizes Available (W x H): 16"x24", 16"x20", 16"x30", 18"x24", 18"x30", 18"x36", 20"x60", 24"x30", 24"x36", 24"x42", 24"x48", 18"x60", 24"x60", 24"x72", 18"x72"

Options:

- LG:** Laminated Glass
- LX:** Polycarbonate
- PM:** Plastic Acrylic
- T:** Tempered Glass
- VC:** Vinyl Clad (Safety Glass)
- 8B:** #8 Reflective Stainless Steel

* Stainless steel mirrors reflect images in different optic quality than plate glass. There will be a slight distortion which increases proportionately with the mirror size. Therefore, AJW Architectural Products™ cannot be held responsible for quality of image.

** Mirrors are always ordered Width x Height

*** Recommended max size for 8B mirrors: 72" x 47-1/2"

**** Framed mirrors are fabricated to a tolerance of (+/-) 1/8"

***** Mirrors conform to Federal Specifications DD-M-00411b & DDg-541D.

INSTALLATION

Coordinate installation with architect / contractor for specific mounting location and height for each mirror application. Making sure "I" bracket is level, transfer all mounting point locations to wall surface from drawing. Secure brackets with proper fasteners for each application. Slide mirror down over horizontal brackets until clip lock secures mirror in place. Mirror can only be removed by inserting tool through hole at bottom of frame depressing clip. This will allow mirror to slide up over brackets. Fillers are available if mirrors are mounted above and below tile line. (U004 Filler) filler material will match mirror frame to form a one piece construction.

To meet ADA Code, bottom edge of reflective surface can be no higher than 40" above finished floor. (4.19.6) Full length mirrors may be used for universal application when installed in correct locations.

Abrasive cleaners & chloric solutions should not be used on mirrors. Discoloring and /or scratching of frame and reflective surface may occur.

NOTES



U812

Toilet Tissue Dispenser

Revision 03/11

JOB #:

ITEM #:

QUANTITY:

MOUNTING	HANDING	TYPE	SIZE	OTHER

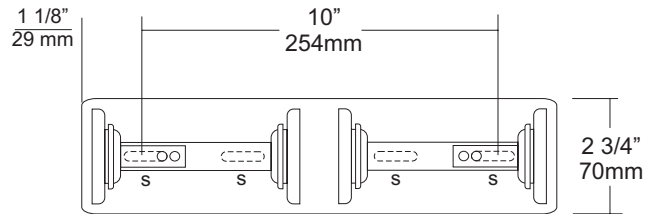
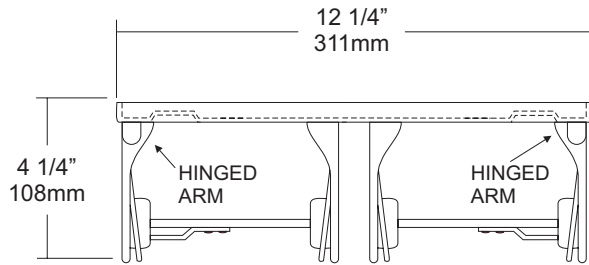

SPECIFICATIONS

Mounting Plate: Bright chrome plated #22 ga steel formed for maximum strength.

Arms: Hinged arms (one for each roll) are #22 ga bright chrome plated. The other arm is fixed. Both arms are fabricated with an extended support to maintain toilet tissue roll. This is a controlled type dispensing system.

Overall Size: 12 1/4"W x 2 3/4"H x 4 1/4"D

311mm x 70mm x 108mm

Capacity: Two standard rolls with a 5 1/4" (133mm) OD.

INSTALLATION

Provide an area on wall surface at desired or specified location. Hold unit to surface and make sure unit is level. Transfer mounting points to wall and drill pilot holes. Secure units with proper fasteners per application. Open units by depressing tab on spindle that allows arm to unlock. Load tissue on spindle and snap close.

Toilet Paper Dispensers: All dispensers that are to meet ADA code cannot have any type of controlled delivery. (4.16)

NOTES



U8504

Uni-Door Seat Cover Dispenser

Revision 05/11

JOB #:

ITEM #:

QUANTITY:

MOUNTING	HANDING	TYPE	SIZE	OTHER

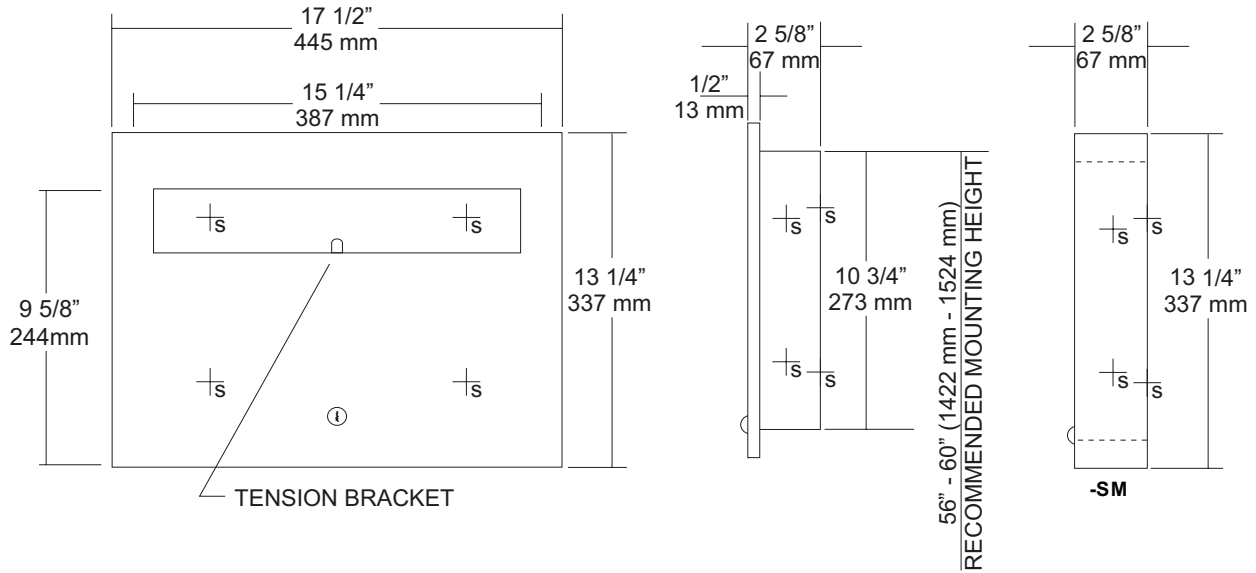

SPECIFICATIONS

Body: Fabricated of #22 gauge stainless steel with a #4 satin finish on all exposed surfaces.

Flange: #22 gauge stainless steel with 1/4" returns to wall without any miters.

Uni-Door: #18 ga stainless steel door. Seat cover dispensing area (on both units) are deburred and polished smooth to avoid paper tearing and injury.

Hinge: Full length, stainless steel piano type hinge.

Lock: Pin tumbler commercial quality, keyed like all other AJW cabinets.

Overall Size: 17 1/2"W x 13 1/4"H x 2 5/8"D
445mm x 337mm x 68mm

Wall Opening: 15 3/4"W x 11 1/4"H x 2 5/8"D
400mm x 286mm x 60mm

U8504-SM: Surface mounted unit

Capacity: 500 seat covers

INSTALLATION

Provide required wall opening at desired or specified location with coordination with architect or contractor to avoid interference with pipes, vents, etc. Unlock cabinet and place unit in opening. Secure to rough framing with proper fasteners per each application. Fill dispenser with product and secure cabinet door.

NOTES



UG3-A

Grab Bars

Revised 03/11

JOB #:

ITEM #:

QUANTITY:

MOUNTING	HANDING	TYPE	SIZE	OTHER



SPECIFICATIONS & INSTALLATION

Tubing: Fabricated of #18 ga stainless steel with a #4 satin finish. Available in 1 1/2" outside diameter. All bends are formed by an automatic mandrel bending process. All bars maintain a constant 1 1/2" offset.

Finish: Standard finish is a #4 satin finish. For a non-slip finish (peened) add suffix X to model number. (Ex. UG3X-A)

Flanges: Snap flanges are fabricated of 3" diameter, 3/8" deep drawn #22 ga stainless steel with #4 satin finish to match tubing. Flanges have dimples that secure over mounting plate.

Strength: Bars with a 1 1/2" offset clearance will support loads in excess of 900lbs when properly installed. Bars with greater offsets will support loads up to 250lbs when properly installed.

Installation: Before installing grab bars, verify with all state and local codes for requirements on bar diameter and type finish. Recommended mounting heights for grab bars are 33" - 36" centerline above finished floor. All mounting of grab bars when possible should have in wall mounting back plates. Find centerline mounting points and place bar on line making sure to be on center. Transfer mounting points (3 per flange) to wall. Drill pilot holes and secure bar with proper anchors per application. Snap cover over mounting plate.

Standard Lengths (Other sizes available upon request): 12", 16", 18", 24", 30", 32", 36", 42", 48", 50", 52", 54", 56"

FLANGE INFORMATION

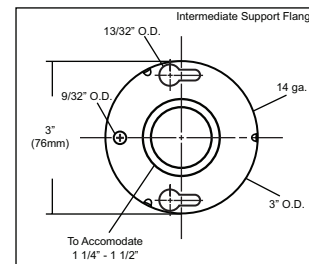
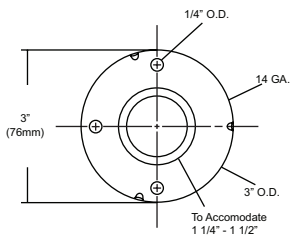
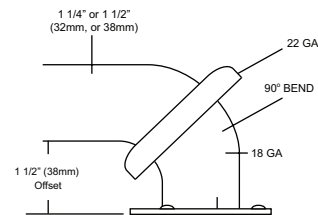

NOTES



UJ13 Series

Mop Holder Strip & Shelf Combination Unit

Revision 03/11

JOB #:

ITEM #:

QUANTITY:

MOUNTING	HANDING	TYPE	SIZE	OTHER

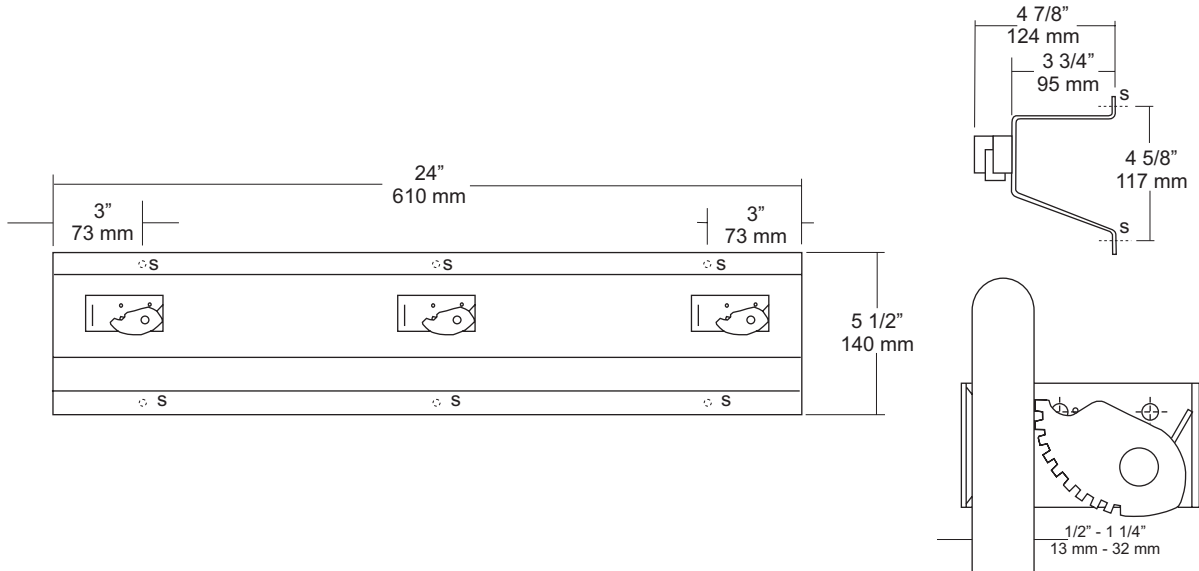

SPECIFICATIONS	INSTALLATION
----------------	--------------

Mop Strip & Shelf: Fabricated of #18 ga stainless steel with a #4 satin finish. Upper portion of strip is formed in the shape of a "hat" channel, that is utilized as a shelf, projects 3 3/4" from wall surface. Lower portion is angled to add rigidity and strength to strip.

Mop Holders: UJ19 plated reinforced steel with serrated cam type hard rubber mop or broom holder. Holds handles 1/2" to 1 1/4" diameter.

Verify Style:

- UJ13A:** 24"L (610mm) with 3 holders.
- UJ13B:** 36"L (914mm) with 4 holders.
- UJ13C:** 48"L (1219mm) with 5 holders.
- UJ13D:** 60"L (1524mm) with 6 holders.

Place unit to wall surface making sure unit is level and transfer mounting points. Drill pilot holes and secure unit with proper fasteners per application.

NOTES
