

date	111
projectname	111
attn	111
from	111
fax	
email	
phone	111



U180

Folded Towel Dispenser

Revision 03/11

JOB #:

ITEM #:

QUANTITY:

MOUNTING	HANDING	TYPE	SIZE	OTHER

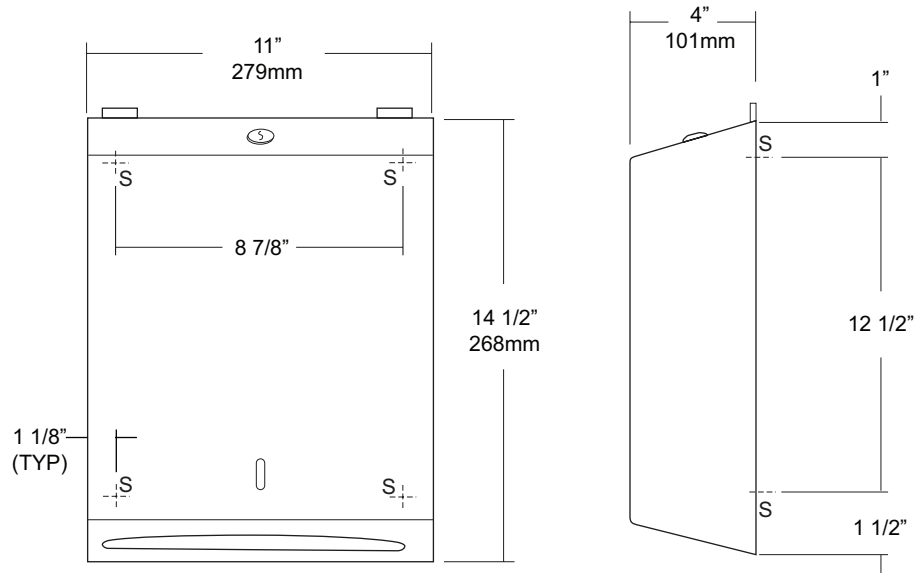

SPECIFICATIONS

Cabinet: #22 ga. stainless steel with #4 satin finish. Striker tabs prevents damage to mounting surface when cover is closed. (Unibody design)

Cabinet Back: #22 ga stainless steel with embossed towel guides.

Hinges: Full length, heavy duty, stainless steel , piano type hinge. (Welded, no rivets)

Locks: Pin tumbler, commercial quality, keyed like all other AJW cabinets.

Towel Dispenser: Area is hemmed to prevent towel tearing and injury.

Overall Size: 11"W x 14 1/2"H x 4"D (stainless steel)
279mm x 368mm x 102mm

Capacity: 400 c-fold or 525 multifold

Options:

- TK: Twist lock in lieu of keyed lock.

INSTALLATION

Provide an area on mounting surface at desired or specified location. Open cover and place unit against wall and transfer mounting points after checks out to be level and is at the proper mounting height. Secure unit to surface with proper fasteners, fill cabinet with towels, close cover and remove key.

Recommend towel dispensing area at a height of 40" above finished floor to meet ADA Code.

NOTES



U472-13

Free Standing Waste Receptacle

Revision 03/11

JOB #:

ITEM #:

QUANTITY:

MOUNTING	HANDING	TYPE	SIZE	OTHER

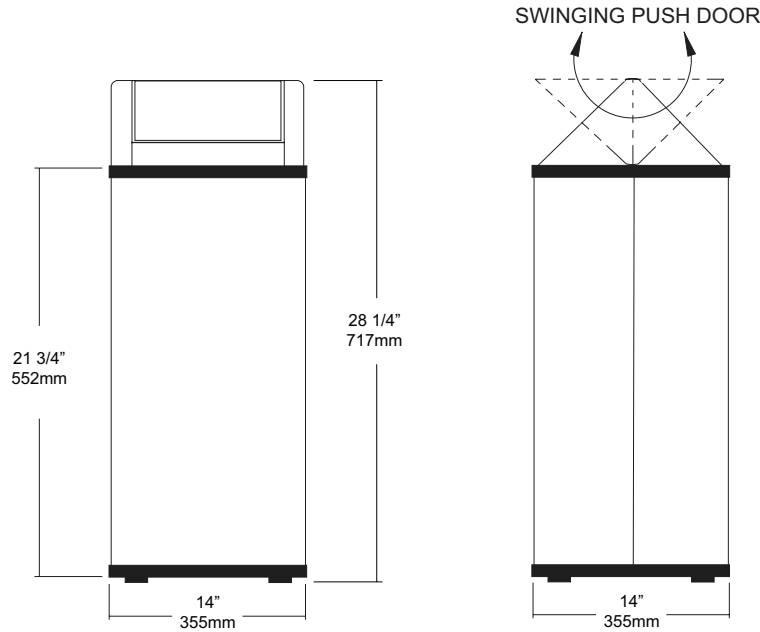

SPECIFICATIONS

Body: Fabricated of #22 ga stainless steel with a #4 satin finish. Fully welded construction to form a one-piece body with radius corners to prevent injury. Each corner has an additional angled bracket to insure maximum rigidity.

Swing Top: Fabricated of #20 ga stainless steel with #4 satin finish. Fully welded construction and heavy duty internal mechanism allows flip top to pivot in both directions. All areas around opening have been hemmed and deburred to prevent injury.

Base: Fabricated of stainless steel welded to body with multiple welds.

Bumpers: Top and bottom wall vinyl bumpers protect wall surface from damage when receptacle is being moved around or serviced.

Feet: Rubber feet provide unit stability and prevent floor from being scratched.

Overall Size: 14"W x 28 1/4"H x 14"D

355mm x 717mm x 355mm

Waste Capacity: 13 gallons (1.73 cu ft)

INSTALLATION

Waste receptacles can be placed in area that will not interfere or obstruct passage areas. Units can be easily serviced by removing swing top and emptying contents.

NOTES

Formerly Model #: U470-13/473



U704 Series

Fixed Tilt Angle Frame Mirror

Revision 11/15

JOB #:

ITEM #:

QUANTITY:

MOUNTING	HANDING	TYPE	SIZE	OTHER

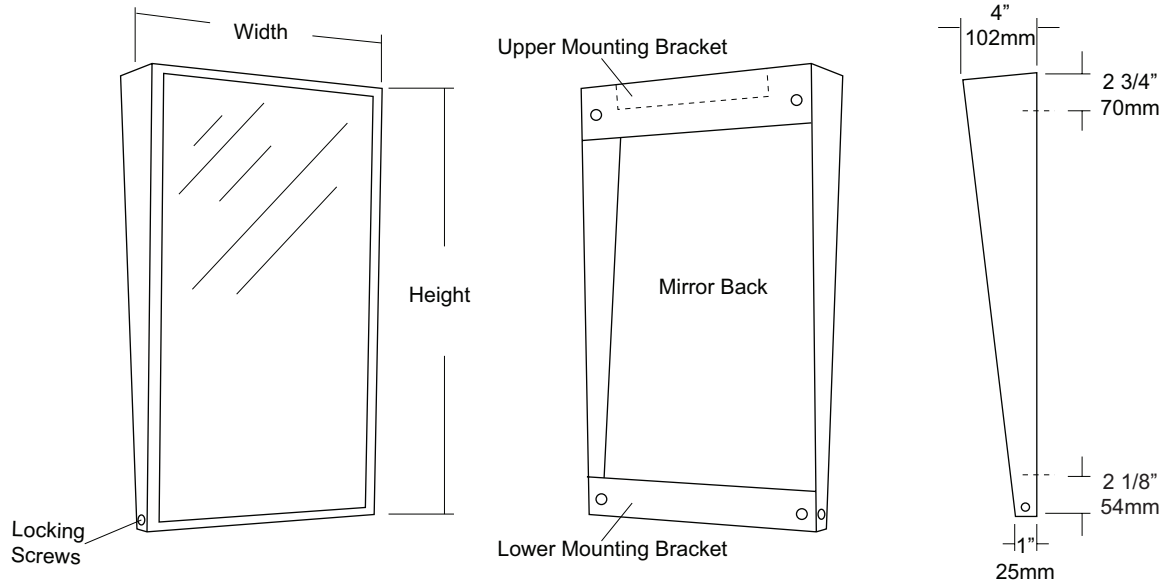

SPECIFICATIONS

Frame: Fabricated of #18 ga stainless steel, #4 satin finish. Stainless steel frame is fabricated with welded mitered corners that are ground and polished smooth. Mirror extends out 4" at top and tapers to 1" at bottom.

Mirror: 1/4" thick type 1 transparent flat type, class 1 - clear glass mirrors. Mirror is coated with silver and sealed with a uniform electrolytic copper plating, along with two coats of paint for added protection. Mirrors are guaranteed against silver spoilage for a period of 15 years. Mirrors conform to ASTM C1036 and ASTM C1503-R8.

Filler: 3/16" thick full size, shock absorbing, water resistant, non-abrasive polyethylene padding protects all concealed mirror surfaces

Brackets: Mounting brackets are fabricated of #20 ga pre-plated, galvanized steel. Lower bracket has two (2) side mounting points that allow frame to be secured to bracket.

Standard Sizes Available (W x H): 16"x24", 16"x30", 18"x24", 18"x30", 18"x36", 24"x30", 24"x36"

Options:

LG: Laminated Glass

LX: Polycarbonate

PM: Plastic Acrylic

T: Tempered Glass

VC: Vinyl Clad (Safety Glass)

8B: #8 Reflective Stainless Steel

*Stainless steel mirrors reflect images in different optic quality than plate glass. There will be a slight distortion which increases proportionately with the mirror size. Therefore, AJW Architectural Products™ cannot be held responsible for quality of image.

** Mirrors are always ordered Width x Height

*** Recommended max size for 8B mirrors: 72" x 47-1/2"

**** Framed mirrors are fabricated to a tolerance of (+/-) 1/8"

***** Mirrors conform to Federal Specifications DD-M-00411b & DD-g-541D

INSTALLATION

Coordinate installation with architect / contractor for specific mounting location and height for each mirror application. Check all state and local codes for installation requirements. Remove hanger brackets and transfer mounting points to wall surface. Secure with proper fasteners for each application. Slide mirror frame over brackets and secure in place. Secure frame to bracket. Fillers are available if mirrors are mounted above and below tile line. (U004 Filler) Filler material will match mirror frame to form a one piece construction.

To meet ADA Code, bottom edge of reflective surface can be no higher than 40" above finished floor. (4.19.6) Full length mirrors may be used for universal application when installed in correct locations.

Abrasive cleaners & chloric solutions should not be used on mirrors. Discoloring or scratching may occur on frame and reflective surface.

NOTES



U860

Seat Cover, Sanitary Napkin Disposal & Toilet Tissue Dispenser Combination Unit

Revision 03/11

JOB #:

ITEM #:

QUANTITY:

MOUNTING	HANDING	TYPE	SIZE	OTHER

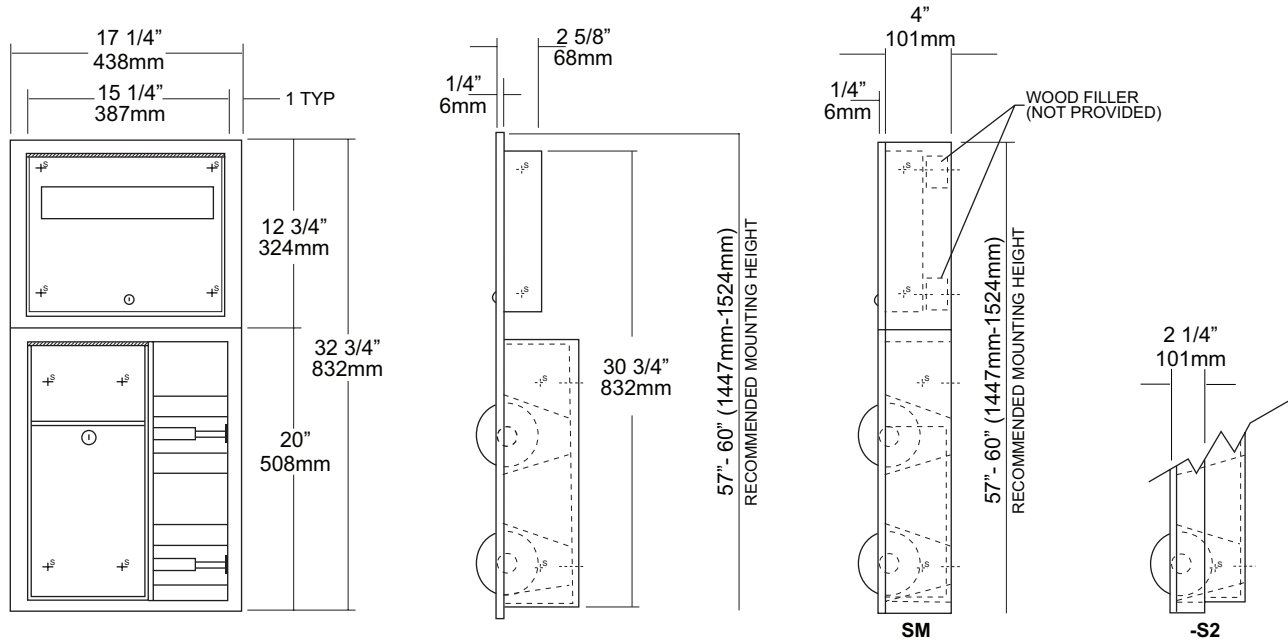

SPECIFICATIONS

- Cabinet:** Fabricated of #22 gauge stainless steel. All exposed surfaces have a #4 satin finish.
- Flange:** Fabricated of #22 gauge stainless steel one-piece drawn seamless construction. No seams or exposed miters with 1/4" returns to wall surface.
- Napkin Disposal:** Self closing push panel door is fabricated of #22 gauge stainless steel. Removable Waste is fabricated of same material with pin tumbler lock. Waste is identified with International Graphic symbol.
- Toilet Tissue Dispenser:** #22 gauge stainless steel hat adapters secure chrome plated, spring loaded rollers in place.
- U007 Theft Resistant Adapter:** Prevents spindle from being removed until roll has been depleted.
- Seat Cover Dispenser:** #22 gauge stainless steel secured by pin tumbler lock.
- Hinges:** All hinges are full length, heavy duty, stainless steel piano type hinges.
- Collars:** #22 ga stainless steel finished to match cabinet.
- Overall Size:** 17 1/4"W x 32 3/4"H x 4 1/4"D
438mm x 832mm x 108mm
- Wall Opening:** 15 3/4"W x 31 1/4"H x 4"D
400mm x 793mm x 102mm
- U860-S2:** 2" semi-recessed. collar, 2" wall opening, 51 mm
- U860-SM:** Full surface mounted collar.
- Waste Capacity:** 2 Gallons (.26 cu ft)
- Toilet Tissue:** Two standard rolls with a 5 1/4" (133mm) OD.
- Seat Cover Capacity:** 500

INSTALLATION

Provide rough wall opening at desired or specified location of 15 3/4"W x 31 3/4"H. (Depth of opening will depend on type mounting required.) Place lower unit in opening. Before securing place seat cover dispenser in opening to ensure proper fit. If both units fit properly in opening, secure bottom unit than the top. If collars are required, place collar onto the units from the back before securing to mounting area. Fill seat cover dispenser and toilet tissue rolls.

Toilet Paper Dispensers: All dispensers that are to meet ADA code cannot have any type of controlled delivery. (4.16)

NOTES



U860A

Seat Cover & Toilet Tissue Dispenser Combination Unit

Revision 03/11

JOB #:

ITEM #:

QUANTITY:

MOUNTING	HANDING	TYPE	SIZE	OTHER

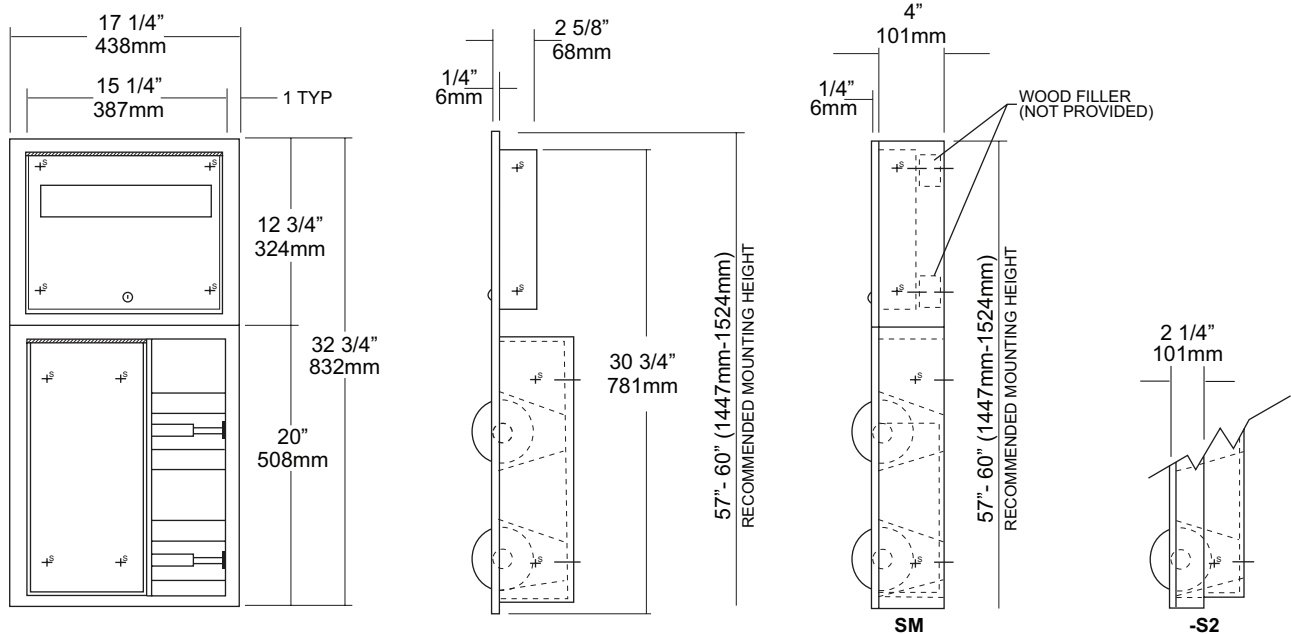

SPECIFICATIONS

Cabinet: Fabricated of #22 gauge stainless steel. All exposed surfaces have a #4 satin finish.

Flange: Fabricated of #22 gauge stainless steel one-piece drawn seamless construction. No seams or exposed miters with 1/4" returns to wall surface.

Toilet Tissue Dispenser: #22 gauge stainless steel hat adapters secure chrome plated, spring loaded rollers in place.

U007 Theft Resistant Adapter: Prevents spindle from being removed until roll has been depleted.

Seat Cover Dispenser: #22 gauge stainless steel secured by pin tumbler lock.

Hinges: All hinges are full length, heavy duty, stainless steel piano type hinges.

Collars: #22 ga stainless steel finished to match cabinet.

Overall Size: 17 1/4"W x 32 3/4"H x 4 1/4"D
438mm x 832mm x 108mm

Wall Opening: 15 3/4"W x 31 1/4"H x 4"D
400mm x 793mm x 102mm

U860A-S2: semi-recessed with 2" collar, 2" wall opening.

U860A-SM: Surface Mounted cabinet.

Toilet Tissue: Two standard rolls with a 5 1/4" (133mm) OD.

Seat Cover Capacity: 500

INSTALLATION

Provide rough wall opening at desired or specified location of 15 3/4"W x 31 1/4"H. (Depth of opening will depend on type mounting required.) Place lower unit in opening. Before securing place seat cover dispenser in opening to ensure proper fit. If both units fit properly in opening, secure bottom unit than the top. If collars are required, place collar onto the units from the back before securing to mounting area. Fill seat cover dispenser and toilet tissue rolls.

Toilet Paper Dispensers: All dispensers that are to meet ADA code cannot have any type of controlled delivery. (4.16)

NOTES



U861

Seat Cover, Sanitary Napkin Disposal &
Toilet Tissue Dispenser Combination Unit

Revision 03/11

JOB #:

ITEM #:

QUANTITY:

MOUNTING	HANDING	TYPE	SIZE	OTHER

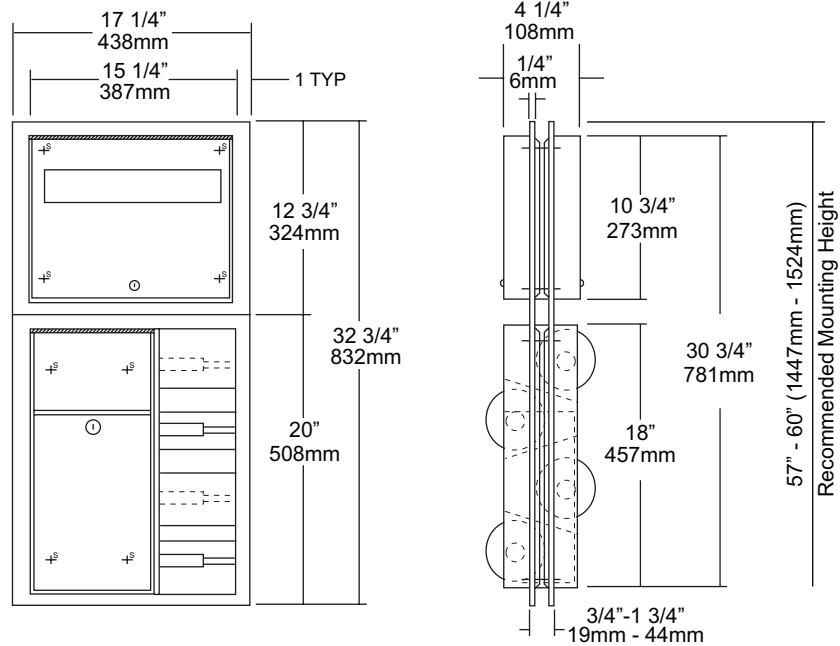

SPECIFICATIONS

- Cabinet:** Fabricated of #22 gauge stainless steel. All exposed surfaces have a #4 satin finish.
- Flanges:** Fabricated of #22 gauge stainless steel one-piece drawn seamless construction. No seams or exposed miters with 1/4" returns to wall surface. (Exposed mounting points)
- Napkin Disposal:** Self closing push panel door is fabricated of #22 gauge stainless steel. Removable Waste is fabricated of same material with pin tumbler lock. Waste is identified with International Graphic symbol.
- Toilet Tissue Dispenser:** #22 gauge stainless steel hat adapters secure chrome plated, spring loaded rollers in place.
- U007 Theft Resistant Adapter:** Prevents spindle from being removed until roll has been depleted.
- Seat Cover Dispenser:** #22 gauge stainless steel secured by pin tumbler lock.
- Hinges:** All hinges are full length, heavy duty, stainless steel piano type hinges.
- Overall Size:** 17 1/4"W x 32 3/4"H x 4 1/4"D
438mm x 832mm x 108mm
- Adjustable to fit partitions** 1/2" - 1 1/4" thick.
- Wall Opening:** 15 3/4"W x 31 1/4"H
400mm x 768mm
- Waste Capacity:** 2 Gallons (.26 cu ft)
- Toilet Tissue:** Four standard rolls with a 5 1/4" (133mm) OD.
- Seat Cover Capacity:** 1000

INSTALLATION

Provide rough wall opening at desired or specified location of 15 3/4"W x 31 1/4"H. Place lower unit in opening. Before securing place seat cover dispenser in opening to ensure proper fit. If both units fit properly in opening, secure bottom unit than the top by the side with the fixed flange and exposed mounting points. Secure adjustable flange last in the same manor. Secure with proper fasteners per each application. Fill seat cover dispenser and toilet tissue rolls.

Toilet Paper Dispensers: All dispensers that are to meet ADA code cannot have any type of controlled delivery. (4.16)

NOTES



U861A

Seat Cover & Toilet Tissue Dispenser Combination Unit

Revision 03/11

JOB #:

ITEM #:

QUANTITY:

MOUNTING	HANDING	TYPE	SIZE	OTHER

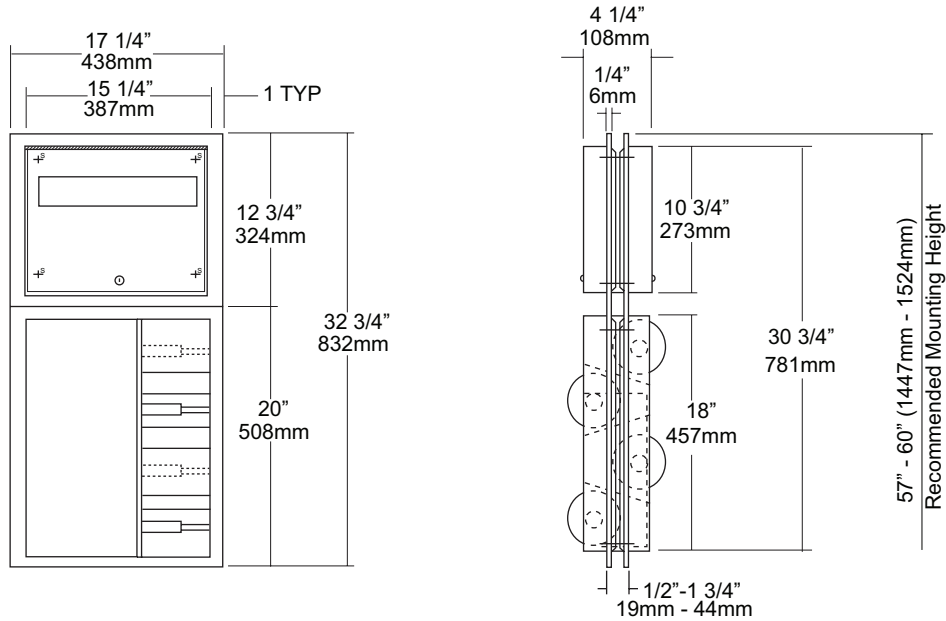

SPECIFICATIONS

Cabinet: Fabricated of #22 gauge stainless steel. All exposed surfaces have a #4 satin finish.

Adj. Flanges: Fabricated of #22 gauge stainless steel one-piece drawn seamless construction. No seams or exposed miters with 1/4" returns to wall surface. (Exposed mounting points)

Toilet Tissue Dispenser: #22 gauge stainless steel hat adapters secure chrome plated, spring loaded rollers in place.

U007 Theft Resistant Adapter: Prevents spindle from being removed until roll has been depleted.

Seat Cover Dispenser: #22 gauge stainless steel secured by pin tumbler lock.

Hinges: All hinges are full length, heavy duty, stainless steel piano type hinges.

Overall Size: 17 1/4"W x 32 3/4"H x 4 1/4"D
438mm x 832mm x 108mm

Adjustable to fit partitions 1/2" - 1 1/4" thick.

Wall Opening: 15 3/4"W x 31 1/4"H
400mm x 806mm

Toilet Tissue: Four standard rolls with a 5 1/4" (133mm) OD.

Seat Cover Capacity: 1000

INSTALLATION

Provide rough wall opening at desired or specified location of 15 3/4"W x 31 1/4"H. Place lower unit in opening. Before securing place seat cover dispenser in opening to ensure proper fit. If both units fit properly in opening, secure bottom unit than the top by the side with the fixed flange and exposed mounting points. Secure adjustable flange last in the same manor. Secure with proper fasteners per each application. Fill seat cover dispenser and toilet tissue rolls.

Toilet Paper Dispensers: All dispensers that are to meet ADA code cannot have any type of controlled delivery. (4.16)

NOTES



UG2-A

Grab Bars

Revised 03/11

JOB #:

ITEM #:

QUANTITY:

MOUNTING	HANDING	TYPE	SIZE	OTHER



SPECIFICATIONS & INSTALLATION

Tubing: Fabricated of #18 ga stainless steel with a #4 satin finish. Available in 1 1/4" outside diameter. All bends are formed by an automatic mandrel bending process. All bars maintain a constant 1 1/2" offset.

Finish: Standard finish is a #4 satin finish. For a non-slip finish (peened) add suffix X to model number. (Ex. UG2X-A)

Flanges: Snap flanges are fabricated of 3" diameter, 3/8" deep drawn #22 ga stainless steel with #4 satin finish to match tubing. Flanges have dimples that secure over mounting plate.

Strength: Bars with a 1 1/2" offset clearance will support loads in excess of 900lbs when properly installed. Bars with greater offsets will support loads up to 250lbs when properly installed.

Installation: Before installing grab bars, verify with all state and local codes for requirements on bar diameter and type finish. Recommended mounting heights for grab bars are 33" - 36" centerline above finished floor. All mounting of grab bars when possible should have in wall mounting back plates. Find centerline mounting points and place bar on line making sure to be on center. Transfer mounting points (3 per flange) to wall. Drill pilot holes and secure bar with proper anchors per application. Snap cover over mounting plate.

Standard Lengths (Other sizes available upon request): 12", 16", 18", 24", 30", 32", 36", 42", 48", 50", 52", 54", 56"

FLANGE INFORMATION

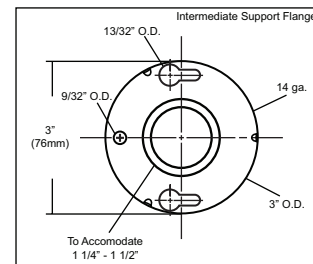
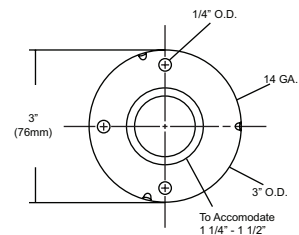

NOTES