

date
projectname
attn
from
fax
email
phone

10-3-2016
Aspinwall Marina
Bob Stewart
John Olszewski
724-693-8766
john@olszewskisales.com
724-693-2666



U126 Soap Dispenser

Revision 11/14

JOB #:

ITEM #:

QUANTITY:

MOUNTING	HANDING	TYPE	SIZE	OTHER

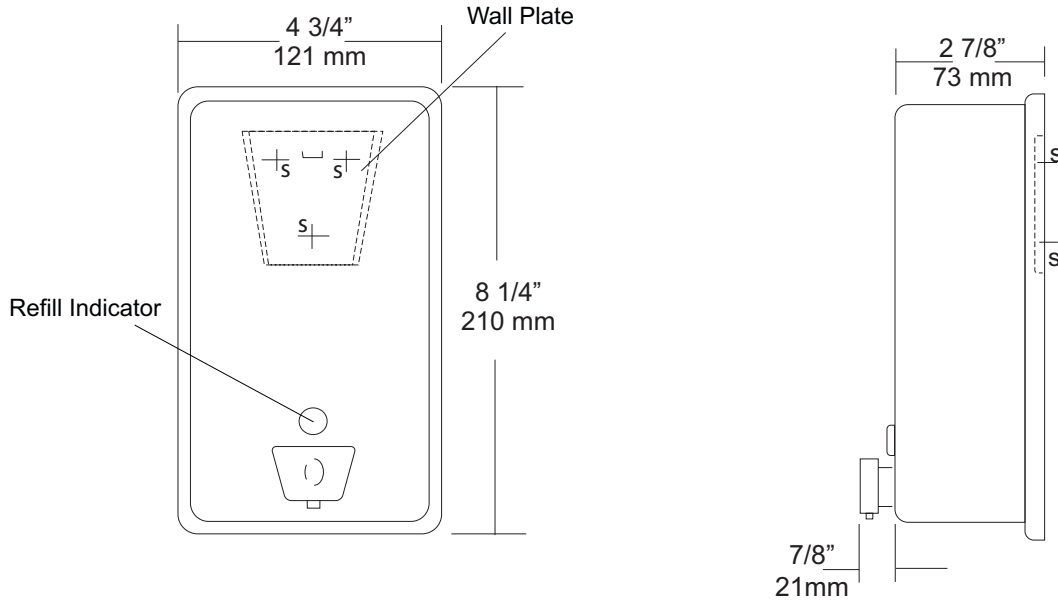

SPECIFICATIONS

Soap Tank: Fabricated of #20 ga stainless steel, #4 satin finish, fully welded one-piece construction.

Valve: All purpose antibacterial soap valve cylinder, black molded plastic push style valve that takes less than 5 lbs of force and one hand to operate complies with barrier free guidelines when mounted at proper height.

Viewer: Clear plastic window allows a constant fluid level check.

Concealed Mounting Plate: Fabricated of heavy gauge stainless steel.

Filler Cap: Fabricated of stainless steel, hinged to allow easy servicing, secured with special key that creates a vandal resistant dispenser.

Overall Size: 4 3/4"W x 8 1/4"H x 3 3/4"D (wall to valve)
121mm x 210mm x 95mm

Capacity: 40 oz.

Recommend type soaps without chloric solutions for proper operation.

INSTALLATION

Provide an area on mounting surface at desired or specified location. Secure concealed mounting plate to wall surface with proper fasteners. Slide dispenser down over mounting plate and secure by means of set screw located inside tank. Fill unit with proper soap. Close lid and secure with special key. Test valve for proper operation.

*It is not recommended to mount any soap dispenser on mirrors

**For best performance, use pre-mixed low concentrate solutions. Dispensers should have periodic maintenance performed to insure the life dispenser. Rinse out globe and valve with warm water to avoid sludge buildup.

Preventative Maintenance: Each dispenser should be flushed out aprx. Every 30 days with warm water to prevent valve from clogging with old soap. Do not use abrasive cleaners to clean dispenser.

NOTES



U650

Folded Towel & Waste Combination Unit

Revision 10/14

JOB #:

ITEM #:

QUANTITY:

MOUNTING	HANDING	TYPE	SIZE	OTHER

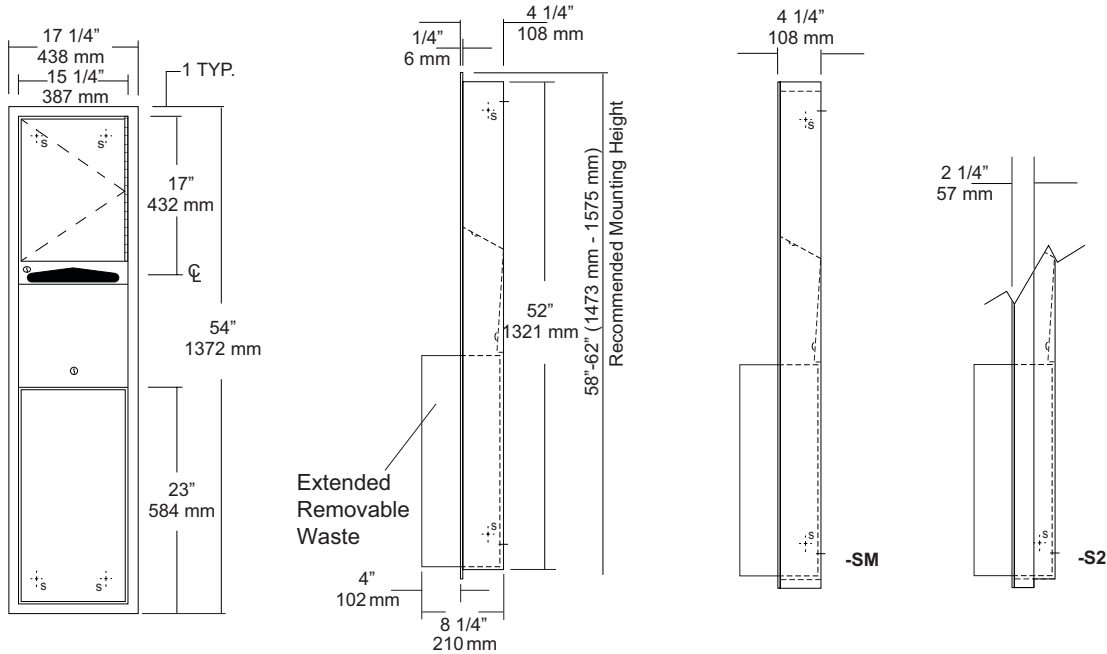

SPECIFICATIONS

Body: Fabricated of #22 ga stainless steel with a #4 satin finish.

Flange: Fabricated of #22 ga stainless steel finished to match cabinet with 1/4" returns. (No miters or welds)

Cabinet Back: Fabricated of stainless steel formed for rigidity with multiple welds to cabinet body.

Cabinet Door: Fabricated of #22 ga stainless steel with #4 satin finish.

Towel Dispenser: Fabricated of #22 ga stainless steel with hemmed edges to prevent injury and towel tearing.

Removable Waste: Fabricated of #22 ga stainless steel #4 satin finish with all leading edges to have a radius. Unit is secured in place by a bottom bracket guide and top lock.

Hinge: Full length, heavy duty, stainless steel piano type hinge.

Locks: Pin tumbler commercial quality, keyed like all other AJW cabinets.

Collars: Fabricated of #22 ga stainless steel, finished to match cabinet. (Used when full recessing cannot be accomplished)

Overall Size: 17 1/4"W x 54"H x 8 1/4"D
438mm x 1372mm x 210mm

Wall Opening: 15 3/4"W x 52 1/2"H x 4"D
400mm x 1334mm x 102mm

U650-S2: semi-recessed. with 2" collar, 2" wall opening 51mm

U650-SM: Full surface mounted collar.

Towel Capacity: 600 c-fold or 800 multifold

Waste Capacity: 12 gallons (1.6 cu ft)

Options :

-VL1: Vinyl Liner

INSTALLATION

Coordinate installation with architect and contractor to avoid interference with pipes, vents, etc. Provide a rough wall opening 15 3/4"W x 52 1/2"H. See chart for required wall depth. If collar is required, slide collar over the back before installing into wall. Remove waste from cabinet and mount unit plumb and true in opening with proper fasteners per application. Secure waste in cabinet and load paper towels.

When cleaning cabinet use a non abrasive non-chloric solution and wiped off with the grain of the cabinet.

NOTES

MOUNTING	HANDING	TYPE	SIZE	OTHER
----------	---------	------	------	-------

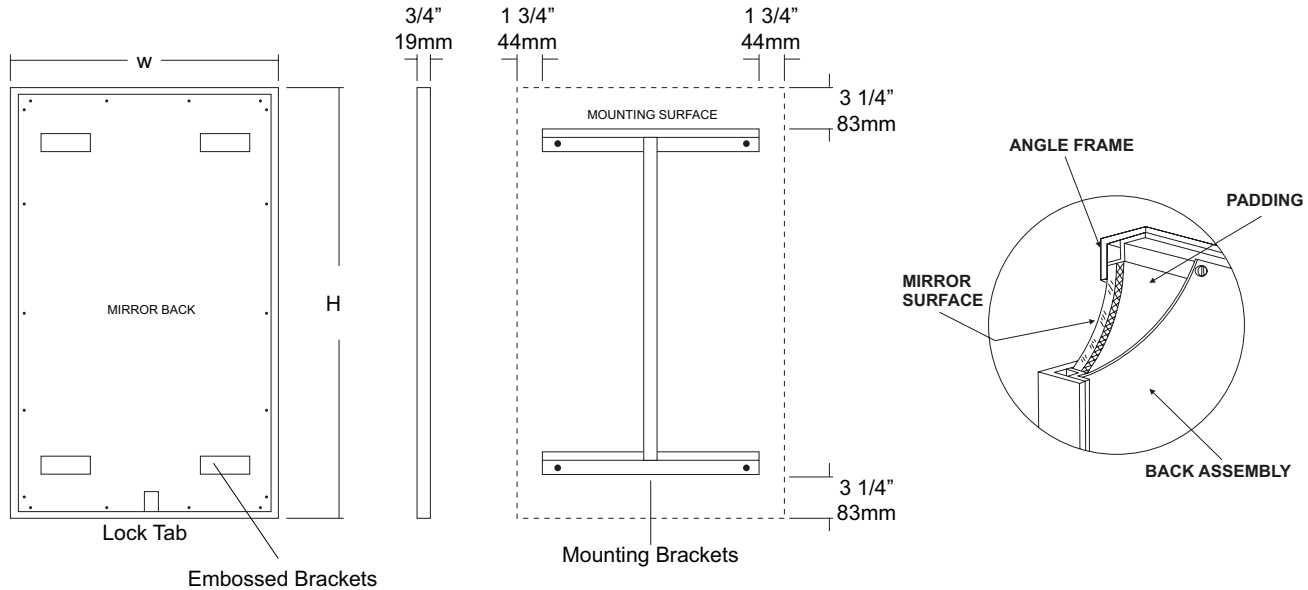

SPECIFICATIONS

Frame: Fabricated of #18 ga stainless steel, #4 satin finish. 3/4" x 3/4" frame with welded mitered corners are ground and polished smooth. #22 ga concealed "Z" channel is spot welded to inner perimeter of frame for reinforcement and greater rigidity.

Mirror: 1/4" thick type 1 transparent flat type, class 1 - clear glass mirrors. Mirror is coated with silver and sealed with a uniform electrolytic copper plating, along with two coats of paint for added protection. Mirrors are guaranteed against silver spoilage for a period of 15 years. Mirrors conform to ASTM C1036 and ASTM C1503-R8.

Filler: 3/16" thick full size, shock absorbing, water resistant, non-abrasive polyethylene padding protects all concealed mirror surfaces.

Back: #20 ga pre-plated galvanized steel, with embossed horizontal louver mounting brackets. Embossed theft resistant pressure activated clip lock device, locks mirror in place to wall hangers. Back is secured to frame with concealed Phillips head screws.

Hangers: Fabricated of #20 ga pre-plated steel galvanized steel with mounting points.

Standard Sizes Available (W x H): 16"x24", 16"x20", 16"x30", 18"x24", 18"x30", 18"x36", 20"x60", 24"x30", 24"x36", 24"x42", 24"x48", 18"x60", 24"x60", 24"x72", 18"x72"

Options:

- LG:** Laminated Glass
- LX:** Polycarbonate
- PM:** Plastic Acrylic
- T:** Tempered Glass
- VC:** Vinyl Clad (Safety Glass)
- 8B:** #8 Reflective Stainless Steel

* Stainless steel mirrors reflect images in different optic quality than plate glass. There will be a slight distortion which increases proportionately with the mirror size. Therefore, AJW Architectural Products™ cannot be held responsible for quality of image.

** Mirrors are always ordered Width x Height

*** Recommended max size for 8B mirrors: 72" x 47-1/2"

**** Framed mirrors are fabricated to a tolerance of (+/-) 1/8"

***** Mirrors conform to Federal Specifications DD-M-00411b & DDg-541D.

INSTALLATION

Coordinate installation with architect / contractor for specific mounting location and height for each mirror application. Making sure "I" bracket is level, transfer all mounting point locations to wall surface from drawing. Secure brackets with proper fasteners for each application. Slide mirror down over horizontal brackets until clip lock secures mirror in place. Mirror can only be removed by inserting tool through hole at bottom of frame depressing clip. This will allow mirror to slide up over brackets. Fillers are available if mirrors are mounted above and below tile line. (U004 Filler) filler material will match mirror frame to form a one piece construction.

To meet ADA Code, bottom edge of reflective surface can be no higher than 40" above finished floor. (4.19.6) Full length mirrors may be used for universal application when installed in correct locations.

Abrasive cleaners & chloric solutions should not be used on mirrors. Discoloring and /or scratching of frame and reflective surface may occur.

NOTES



U812

Toilet Tissue Dispenser

Revision 03/11

JOB #:

ITEM #:

QUANTITY:

MOUNTING	HANDING	TYPE	SIZE	OTHER

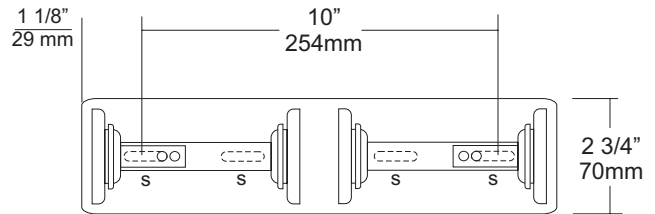
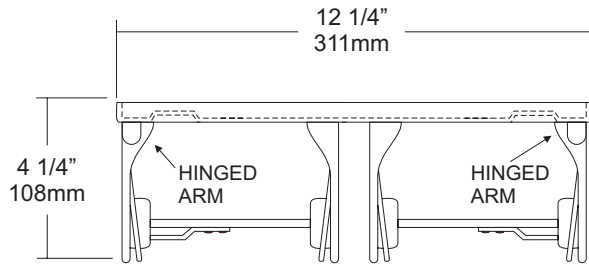

SPECIFICATIONS

Mounting Plate: Bright chrome plated #22 ga steel formed for maximum strength.

Arms: Hinged arms (one for each roll) are #22 ga bright chrome plated. The other arm is fixed. Both arms are fabricated with an extended support to maintain toilet tissue roll. This is a controlled type dispensing system.

Overall Size: 12 1/4"W x 2 3/4"H x 4 1/4"D

311mm x 70mm x 108mm

Capacity: Two standard rolls with a 5 1/4" (133mm) OD.

INSTALLATION

Provide an area on wall surface at desired or specified location. Hold unit to surface and make sure unit is level. Transfer mounting points to wall and drill pilot holes. Secure units with proper fasteners per application. Open units by depressing tab on spindle that allows arm to unlock. Load tissue on spindle and snap close.

Toilet Paper Dispensers: All dispensers that are to meet ADA code cannot have any type of controlled delivery. (4.16)

NOTES



U944

Baby Changing Station

Revision 11/14

JOB #:

ITEM #:

QUANTITY:

MOUNTING	HANDING	TYPE	SIZE	OTHER

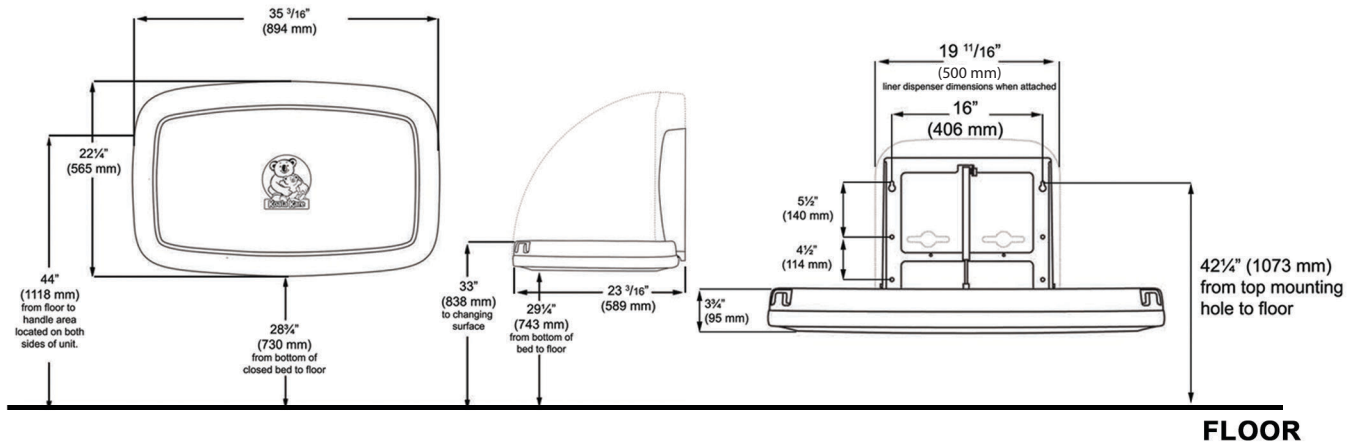

FLOOR

SPECIFICATIONS

Body: FDA approved injection molded polypropylene with Microban antimicrobial additive. Reinforced steel-on-steel hinge mechanism and metal mounting chassis. Labeled usage instructions and safety messages in four languages.

Liner Dispenser: An integral part of body that is standard with each unit. (Capacity: 50)

Pneumatic Cylinder: Concealed pneumatic cylinder & hinge structure provides controlled and smooth open and close motion.

Safety Straps: Nylon safety strap snap lock fastens to hold child securely in place.

Overall Size: 35 3/16"W x 22 1/4"H x 4"D (closed) 23 3/16"D (open)

894mm x 565mm x 102mm (closed), 589mm (open)

Available Colors: Cream & Grey

Optional Braille Label (Not included)

INSTALLATION

Coordinate installation with architect or contractor to avoid interference with surrounding objects. Hold unit up to wall and open to verify there are no obstructions to interfere with operation of station. From finished floor to the top of the unit closed should be at a height of 48". Transfer mounting point locations to wall surface and drill pilot holes. Secure unit with proper fasteners for each application. (Recommend a qualified carpenter to install unit) Unit can be lowered with one hand and into position with less than 5 lbs of force, wall opening turning or twisting of wrist. Verify with local codes and type approach (forward or side) for proper mounting height above finished floor. Unit can support up to 200lbs when properly installed.

Unit should be cleaned once or more daily with a clean nylon brush and spray disinfectant.

When properly installed, baby changing stations comply with ASTM static load performance requirements.

NOTES

Formerly Model #: U945H



UB16

Heavy Duty Chrome Coat Hook

Revision 03/11

JOB #:

ITEM #:

QUANTITY:

MOUNTING	HANDING	TYPE	SIZE	OTHER

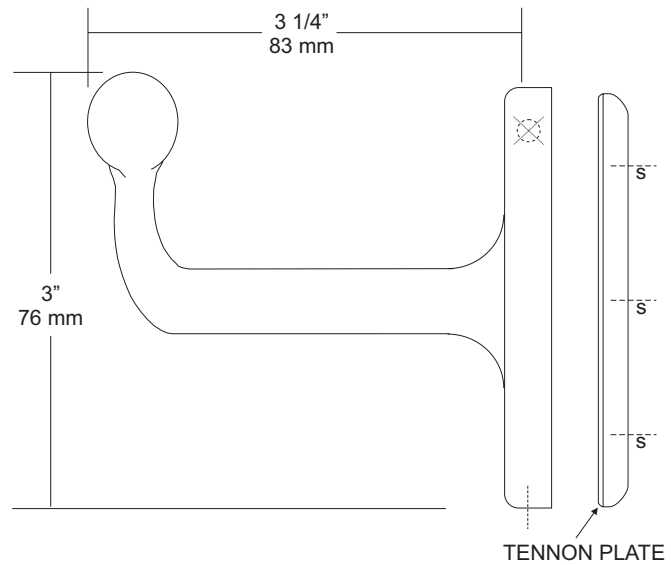
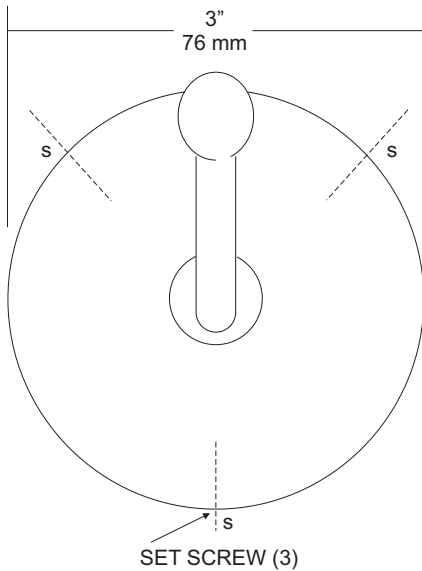

SPECIFICATIONS

UB Accessories: Fabricated of forged brass with a nickel and copper plating of chrome coating. In compliance with all standard commercial and government standards. Three (3) set screws will secure mounting flange to tenon plate providing a concealed mount.

Overall Size: 3"OD x 3"H x 3 1/4"D

76mm x 76mm x 83mm

INSTALLATION

Place tenon plate to wall surface and transfer mounting point locations. Drill pilot holes and secure tenon plate with proper fasteners per application. Place hook around tenon plate making sure hook is aligned properly. Secure flange to tenon plate with three (3) set screws.

NOTES



UG2-A

Grab Bars

Revised 03/11

JOB #:

ITEM #:

QUANTITY:

MOUNTING	HANDING	TYPE	SIZE	OTHER

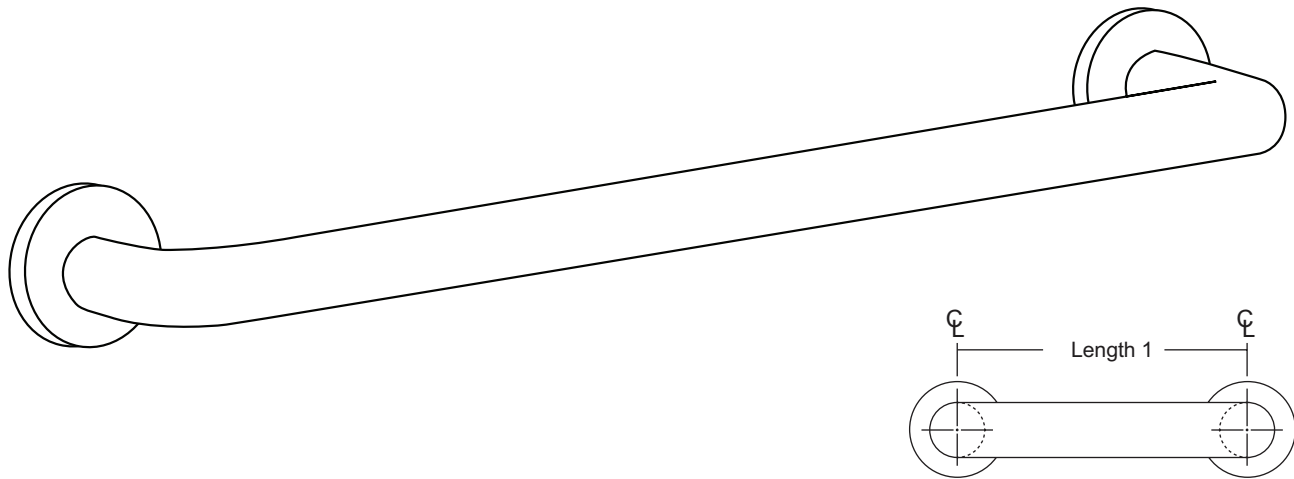

SPECIFICATIONS & INSTALLATION

Tubing: Fabricated of #18 ga stainless steel with a #4 satin finish. Available in 1 1/4" outside diameter. All bends are formed by an automatic mandrel bending process. All bars maintain a constant 1 1/2" offset.

Finish: Standard finish is a #4 satin finish. For a non-slip finish (peened) add suffix X to model number. (Ex. UG2X-A)

Flanges: Snap flanges are fabricated of 3" diameter, 3/8" deep drawn #22 ga stainless steel with #4 satin finish to match tubing. Flanges have dimples that secure over mounting plate.

Strength: Bars with a 1 1/2" offset clearance will support loads in excess of 900lbs when properly installed. Bars with greater offsets will support loads up to 250lbs when properly installed.

Installation: Before installing grab bars, verify with all state and local codes for requirements on bar diameter and type finish. Recommended mounting heights for grab bars are 33" - 36" centerline above finished floor. All mounting of grab bars when possible should have in wall mounting back plates. Find centerline mounting points and place bar on line making sure to be on center. Transfer mounting points (3 per flange) to wall. Drill pilot holes and secure bar with proper anchors per application. Snap cover over mounting plate.

Standard Lengths (Other sizes available upon request): 12", 16", 18", 24", 30", 32", 36", 42", 48", 50", 52", 54", 56"

FLANGE INFORMATION

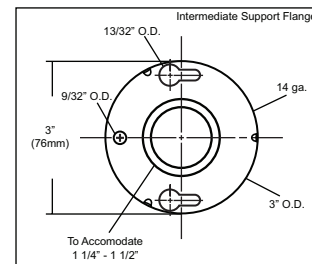
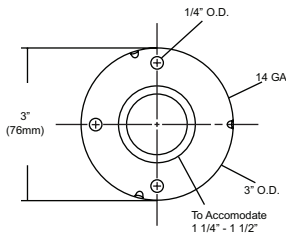
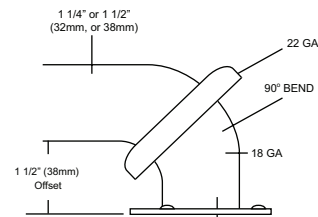

NOTES