

date  
projectname  
attn  
from  
fax  
email  
phone

5/3/21  
smaab # 120  
kim

JOB #:

ITEM #:

QUANTITY:

MOUNTING	HANDING	TYPE	SIZE	OTHER

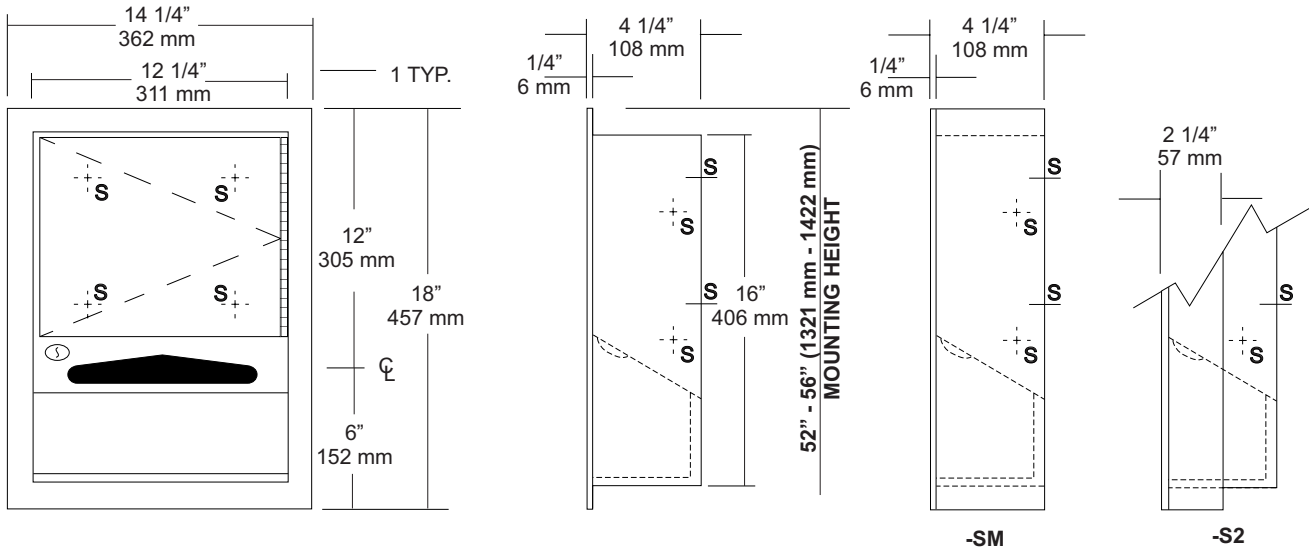

### SPECIFICATIONS

**Cabinet Body:** Fabricated of #22 ga stainless steel. Face trim is an integral part of body with a #4 satin finish and 1/4" returns to wall surface for rigidity. One piece construction without miters or welds.

**Cabinet Door:** Fabricated of #22 ga stainless steel with a #4 satin finish. Full length door stops protect door from vandalism.

**Cabinet Back:** Fabricated of #22 ga stainless steel with multiple welds to cabinet body:

**Towel Dispensing:** Hemmed edges that prevent injury and towel tearing.

**Hinges:** Heavy duty, full length, stainless steel piano type hinge secured door to cabinet.

**Lock:** Commercial quality, pin tumbler type lock keyed like all other AJW accessories.

**Collars:** Fabricated of #22 ga stainless steel finished to match cabinet for surface or recess mounting.

**Overall Size:** 14 1/4"W x 18"W x 4 1/4"D

**362mm x 457mm x 108mm**

**Wall Opening:** 12 3/4"W x 16 1/2"H x 4"D

**324mm x 419mm x 102mm**

**U232-S2:** 2" semi-recessed collar, 2" wall opening 51mm.

**U232-SM:** Full surface mounted collar.

**Capacity:** 350 c-fold or 475 multifold

### INSTALLATION

Coordinate installation with architect and contractor to avoid interference with pipes vents etc. in wall. Provide a rough wall opening 12 3/4"W x 16 1/2"H. See specification for proper wall depth opening. Slip on collars now if collars are required. Open cabinet and insert into wall opening. Secure with proper fasteners per each application. Fill unit with recommended towels, without overfilling. Make sure towels overlap each other so they will be available each time a towel is removed from dispensing area.

Do not use abrasive cleaners or chloric solutions to clean cabinets.

### NOTES

JOB #:

ITEM #:

QUANTITY:

MOUNTING	HANDING	TYPE	SIZE	OTHER

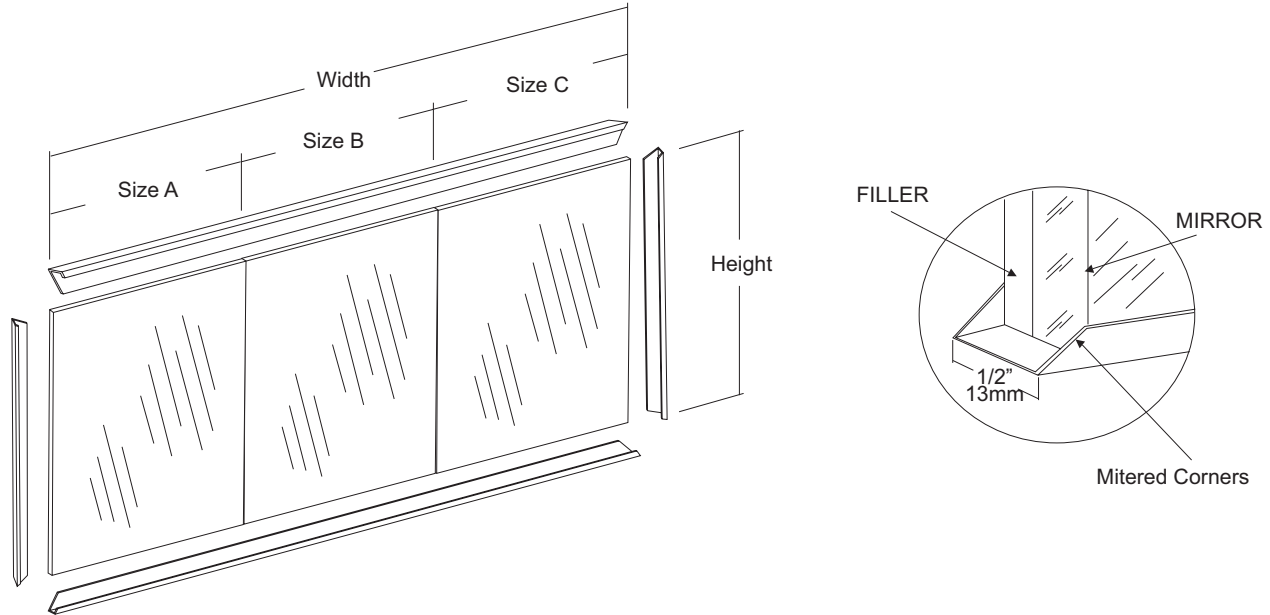

### SPECIFICATIONS

**Mirror:** 1/4" thick type 1 transparent flat type, class 1 - clear glass mirrors. Mirror is coated with silver and sealed with a uniform electrolytic copper plating, along with two coats of paint for added protection. Mirrors are guaranteed against silver spoilage for a period of 15 years. Mirrors conform to ASTM C1036 and ASTM C1503-R8.

**Frame:** #18 ga stainless steel with a #4 satin finish. (1/2" x 1/2" x 1 3/4" channel)

**Backing:** 1/4" thick tempered Masonite backing strips.

**Optional Surfaces & Sizes:**

- PM: Plastic Mirrors (96" x 48" max size for 1 piece of glass)
- PG: Plate Glass (Floor) (96" x 48" max size for 1 piece of glass)
- LG: Laminated Glass (96" x 48" max size for 1 piece of glass)
- T: Tempered Mirror (96" x 48" max size for 1 piece of glass)
- VC: Vinyl Clad (96" x 48" for 1 piece of glass)

**When mirrors are fabricated with multiple pieces of glass, size of each piece must be specified.**

**Mirrors are always ordered Width x Height**

**Fabricated to a tolerance of ± 1/8"**

### INSTALLATION

Mount the bottom channel at desired or specified location. Place a level across the channel to make sure mirror will be level. Place glass and Masonite strips (vertical) in channel and check with level again. Clips are required on the top for securing mirror properly. (SCL-J: stainless steel clips). Measure from the bottom "J" mold up height of mirror and strike a line. Mount top "J" the same way allowing 3/4" to lock glass in place. Place glass and Masonite in channel and slide top "J" down to lock in place. Follow the same instructions for top and bottom style and add the two side "J" channel.

The bottom reflective surface edge must be mounted 40" above finished floor to comply with ADA code, 4.19.6.

### NOTES



# U841 Toilet Tissue Dispenser

Revision 03/11

JOB #:

ITEM #:

QUANTITY:

MOUNTING	HANDING	TYPE	SIZE	OTHER

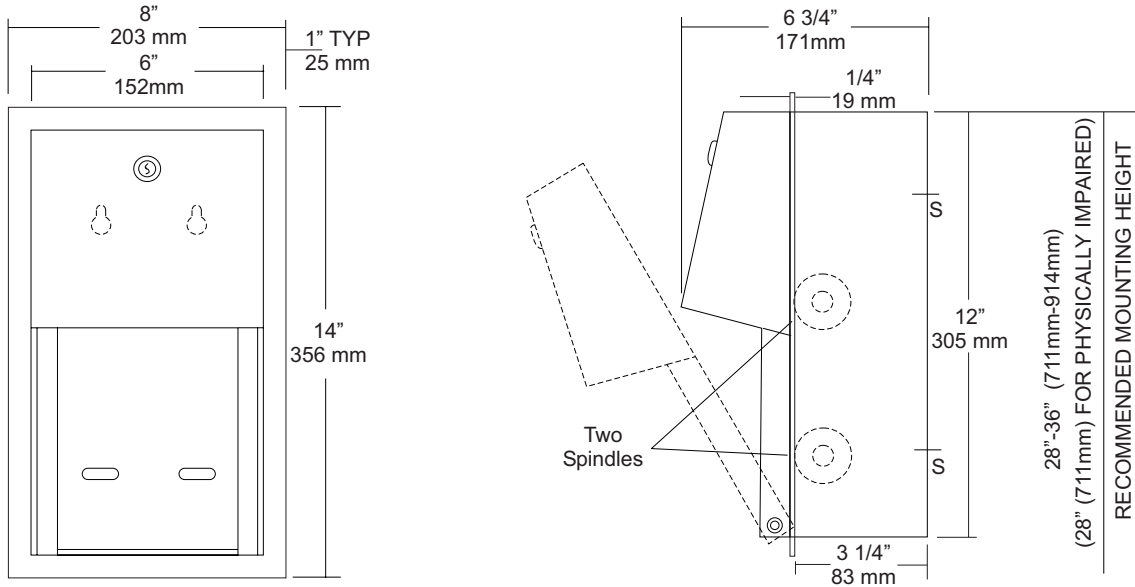

## SPECIFICATIONS

- Body:** Fabricated of #22 ga stainless steel with #4 satin finish. Concealed inner dispensing mechanism is #18 ga stainless steel.
- Back:** Fabricated of #18 ga stainless steel with multiple welds to cabinet body forming a one piece construction.
- Hood:** Fabricated of #18 ga stainless steel finished to match cabinet body. Hood is secured with stainless steel hinge rivets to cabinet body. Top roll of tissue will not drop down unless the bottom roll has been depleted. When unit is closed, this will provide a theft resistant, non-control operation and reduce vandalism.
- Flange:** One piece construction without miters or welds fabricated of #22 ga stainless steel, with #4 satin finish to match cabinet.
- Locks:** Pin tumbler, commercial quality locks keyed like all other AJW cabinets.
- Spindles:** (U005) Fabricated of one-piece molded high impact black ABS material.
- Overall Size:** 8"W x 14"H x 6 3/4"D  
203mm x 356mm x 171mm
- Wall Opening:** 6 3/8"W x 12 3/8"H x 3 5/8"D  
162mm x 314mm x 93mm
- Capacity:** Two standard rolls with a 5 1/4" (133mm) OD.

## INSTALLATION

Coordinate installation with architect or contractor to avoid pipes, vents, etc. Provide a rough wall opening in mounting surface at desired or specified location. Open cabinet, remove spindles and insert into opening. Secure unit with proper fasteners per each application. Load toilet tissue on rollers, place in concealed track and close hood. Raise lower roll against upper and take hand away. Lower roll should fall into place with upper roll remaining up above the hood line. If loaded properly, top roll will not fall for use until bottom roll has been depleted. When servicing dispenser, full rolls must be used on both spindles to insure proper operation.

To meet ADA code, dispensers cannot have any type of control delivery. (4.16)

## NOTES

Formerly Model #: U841A



# U851 Seat Cover Dispenser

Revision 07/15

JOB #:

ITEM #:

QUANTITY:

MOUNTING	HANDING	TYPE	SIZE	OTHER

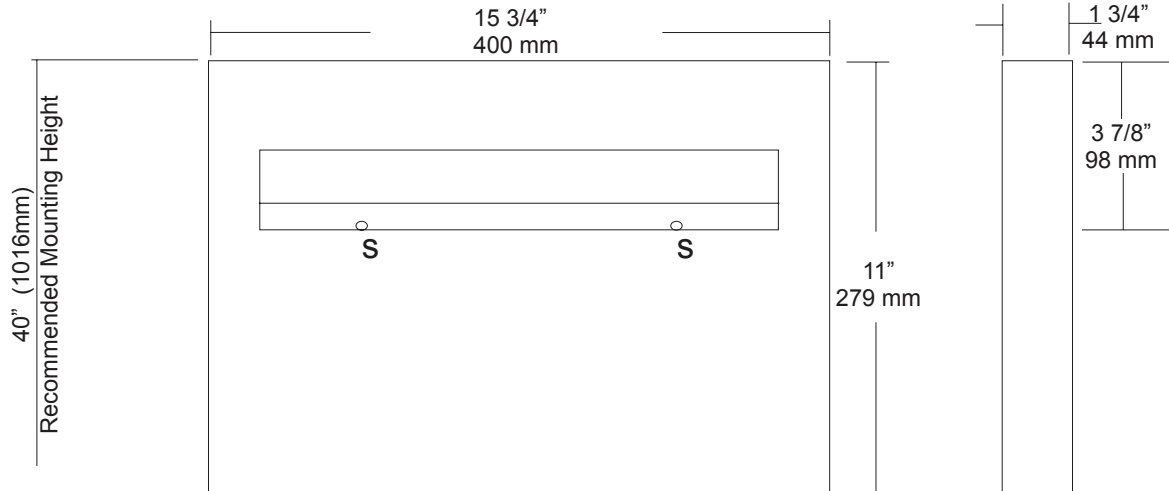

### SPECIFICATIONS

**Dispenser:** Unit is fabricated of #22 gauge stainless steel with a #4 satin finish. Beveled edge around the dispensing areas ensures a clean dispensing area that prevents product from tearing and injury. Loading of product is accomplished from below without having to open any locking mechanism or access panel. Hat style mounting bracket provides added rigidity for body and acts as a support for the packaging.

**Overall Size:** 15 3/4"W x 11"H x 1 3/4"D

**400mm x 279mm x 44mm**

**Capacity:** 500 seat covers

### INSTALLATION

Place unit on wall surface at desired or specified location making sure unit is level. Transfer mounting point locations and drill pilot holes for mounting. Secure unit to surface with proper fasteners per application. Product loads from the bottom out of site from public view.

### NOTES



# UG3-A

Grab Bars

Revised 03/11

JOB #:

ITEM #:

QUANTITY:

MOUNTING	HANDING	TYPE	SIZE	OTHER

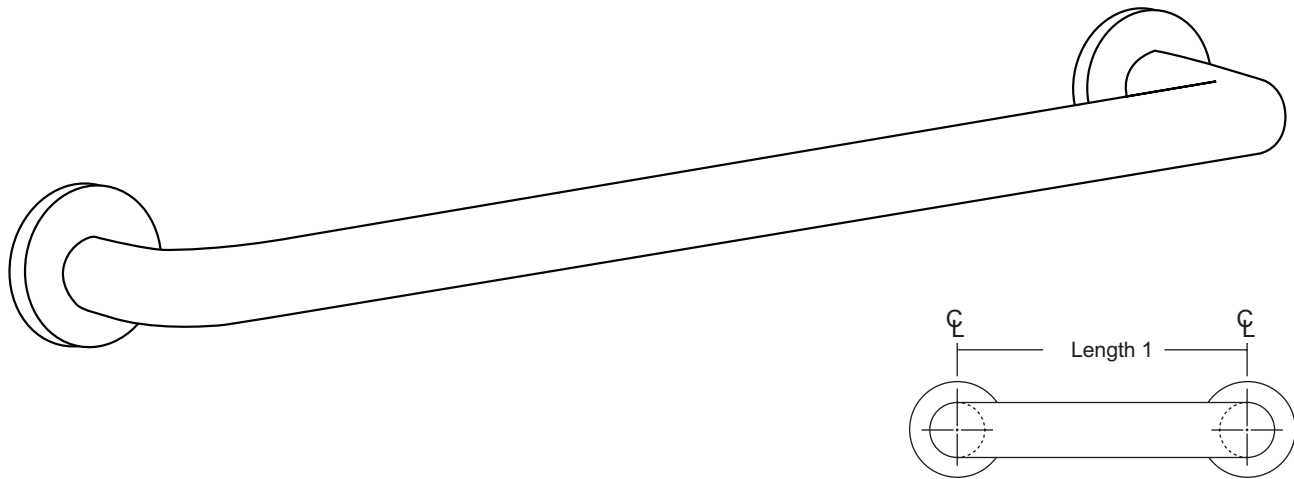

## SPECIFICATIONS & INSTALLATION

**Tubing:** Fabricated of #18 ga stainless steel with a #4 satin finish. Available in 1 1/2" outside diameter. All bends are formed by an automatic mandrel bending process. All bars maintain a constant 1 1/2" offset.

**Finish:** Standard finish is a #4 satin finish. For a non-slip finish (peened) add suffix X to model number. (Ex. UG3X-A)

**Flanges:** Snap flanges are fabricated of 3" diameter, 3/8" deep drawn #22 ga stainless steel with #4 satin finish to match tubing. Flanges have dimples that secure over mounting plate.

**Strength:** Bars with a 1 1/2" offset clearance will support loads in excess of 900lbs when properly installed. Bars with greater offsets will support loads up to 250lbs when properly installed.

**Installation:** Before installing grab bars, verify with all state and local codes for requirements on bar diameter and type finish. Recommended mounting heights for grab bars are 33" - 36" centerline above finished floor. All mounting of grab bars when possible should have in wall mounting back plates. Find centerline mounting points and place bar on line making sure to be on center. Transfer mounting points (3 per flange) to wall. Drill pilot holes and secure bar with proper anchors per application. Snap cover over mounting plate.

**Standard Lengths (Other sizes available upon request):** 12", 16", 18", 24", 30", 32", 36", 42", 48", 50", 52", 54", 56"

## FLANGE INFORMATION

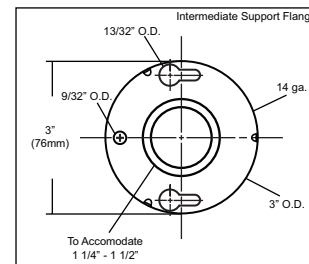
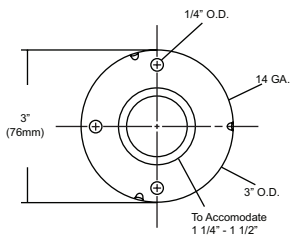
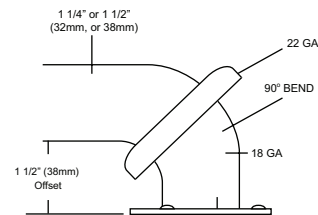

## NOTES



# UX110-BF

Single Robe Hook

Revision 03/11

JOB #:

ITEM #:

QUANTITY:

MOUNTING	HANDING	TYPE	SIZE	OTHER

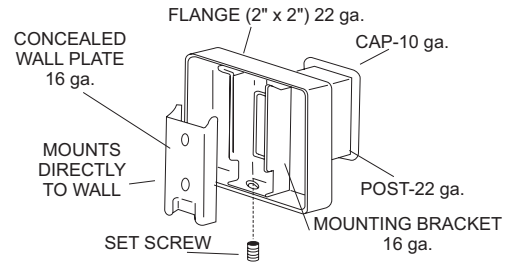
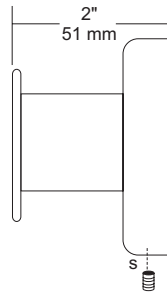
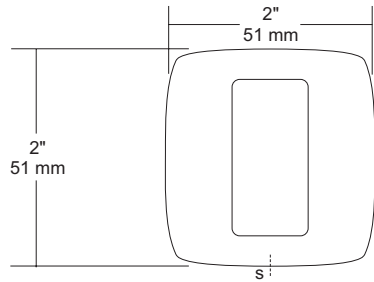

## SPECIFICATIONS

**UX Accessories:** All UX bath accessories series are fabricated of stainless steel with a bright or satin finish. Mounting plates are concealed with a snap-on type plate secured by a set screw.

**Hook:** #10 ga stainless steel hook.

**Flange:** 2" x 2" flange #22 ga stainless steel.

**Post:** #22 ga stainless steel.

**Mounting Plate:** #16 ga concealed wall plate. Set screw secures mounting plate and flange.

**Overall Size:** 2"W x 2"H x 1 5/8"D

**51mm x 51mm x 41mm**

**UX110-SF:** Same as UX110-BF with satin finish

## INSTALLATION

Provide an area on wall surface at desired or specified location. Place concealed mounting plate on wall surface and transfer mounting points. Drill pilot holes and secure with proper fasteners. Place snap on flange over plate and secure with set screw.

## NOTES