

date  
projectname  
attn  
from  
fax  
email  
phone

11-18-21  
BWT PHARMA  
JO ANNE  
WARREN



# U126 Soap Dispenser

Revision 11/14

JOB #:

ITEM #:

QUANTITY:

MOUNTING	HANDING	TYPE	SIZE	OTHER



### SPECIFICATIONS

**Soap Tank:** Fabricated of #20 ga stainless steel, #4 satin finish, fully welded one-piece construction.

**Valve:** All purpose antibacterial soap valve cylinder, black molded plastic push style valve that takes less than 5 lbs of force and one hand to operate complies with barrier free guidelines when mounted at proper height.

**Viewer:** Clear plastic window allows a constant fluid level check.

**Concealed Mounting Plate:** Fabricated of heavy gauge stainless steel.

**Filler Cap:** Fabricated of stainless steel, hinged to allow easy servicing, secured with special key that creates a vandal resistant dispenser.

**Overall Size:** 4 3/4"W x 8 1/4"H x 3 3/4"D (wall to valve)  
**121mm x 210mm x 95mm**

**Capacity:** 40 oz.

**Recommend type soaps without chloric solutions for proper operation.**

### INSTALLATION

Provide an area on mounting surface at desired or specified location. Secure concealed mounting plate to wall surface with proper fasteners. Slide dispenser down over mounting plate and secure by means of set screw located inside tank. Fill unit with proper soap. Close lid and secure with special key. Test valve for proper operation.

\*It is not recommended to mount any soap dispenser on mirrors

\*\*For best performance, use pre-mixed low concentrate solutions. Dispensers should have periodic maintenance performed to insure the life dispenser. Rinse out globe and valve with warm water to avoid sludge buildup.

Preventative Maintenance: Each dispenser should be flushed out aprx. Every 30 days with warm water to prevent valve from clogging with old soap. Do not use abrasive cleaners to clean dispenser.

### NOTES



**U591**  
 Surface Mounted Sanitary Napkin  
 Disposal  
 Revision 1/14

JOB #:
ITEM #:
QUANTITY:

MOUNTING	HANDING	TYPE	SIZE	OTHER

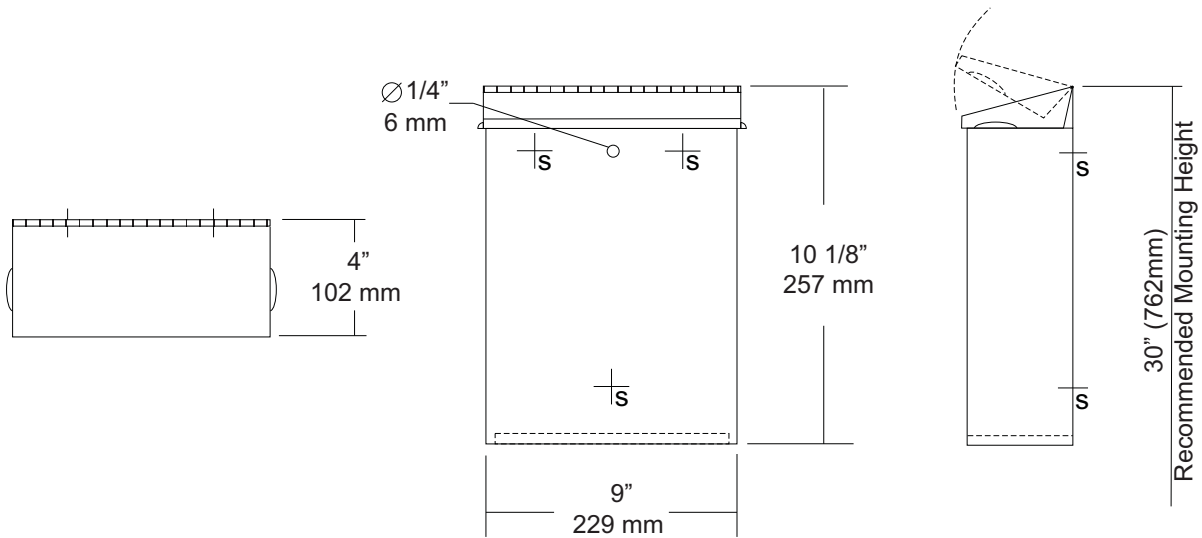

SPECIFICATIONS	INSTALLATION
----------------	--------------

**Cabinet Body:** Fabricated of #22 ga stainless steel with #4 satin finish. Seamless construction with radius and hemmed edges.

**Cabinet Back:** Stainless steel welded to cabinet body with key hole mounting points.

**Cover:** Fabricated of #22 ga stainless steel #4 satin finish with embossed handles on each side and sloped top.

**Hinge:** Heavy duty, full length, stainless steel piano type hinge.

**Overall Size:** 9"W x 10 1/8"H x 4"D

**229mm x 257mm x 102mm**

**Capacity:** 1.6 gallons (.2 cu ft)

**NDL-13-50:** Waxed disposable liners. (50 per Case)

Provide an area at desired or specified location. Place unit on surface and transfer mounting points. Drill pilot holes and secure with proper fasteners. Install waxed liner.

NOTES
-------

--



# U650

## Folded Towel & Waste Combination Unit

Revision 10/14

JOB #:

ITEM #:

QUANTITY:

MOUNTING	HANDING	TYPE	SIZE	OTHER

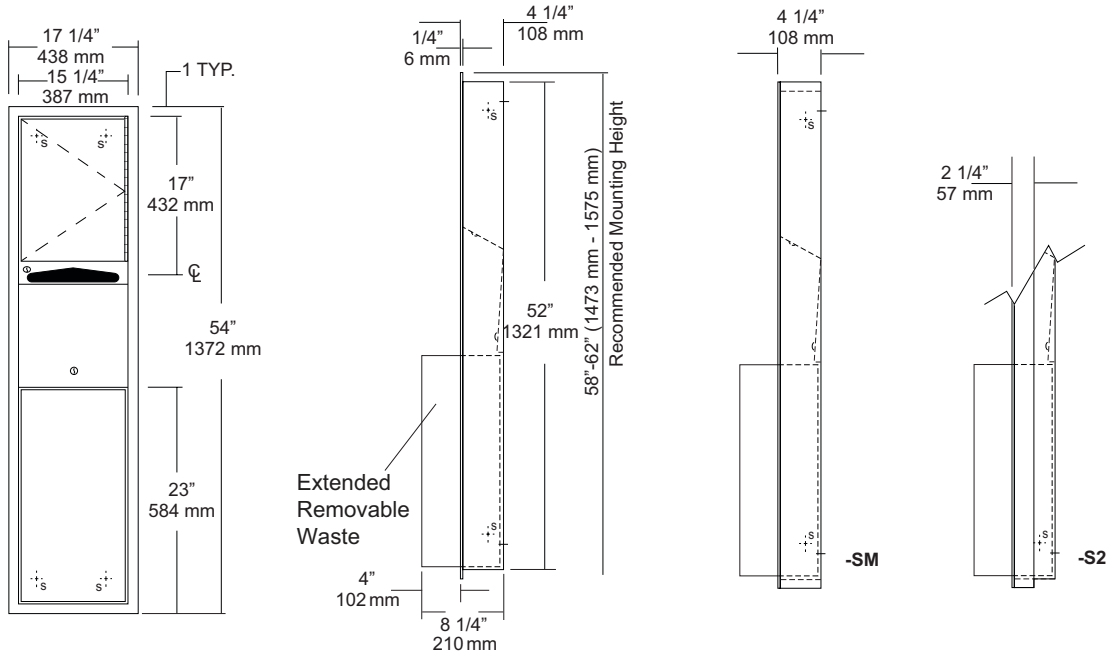

### SPECIFICATIONS

**Body:** Fabricated of #22 ga stainless steel with a #4 satin finish.

**Flange:** Fabricated of #22 ga stainless steel finished to match cabinet with 1/4" returns. (No miters or welds)

**Cabinet Back:** Fabricated of stainless steel formed for rigidity with multiple welds to cabinet body.

**Cabinet Door:** Fabricated of #22 ga stainless steel with #4 satin finish.

**Towel Dispenser:** Fabricated of #22 ga stainless steel with hemmed edges to prevent injury and towel tearing.

**Removable Waste:** Fabricated of #22 ga stainless steel #4 satin finish with all leading edges to have a radius. Unit is secured in place by a bottom bracket guide and top lock.

**Hinge:** Full length, heavy duty, stainless steel piano type hinge.

**Locks:** Pin tumbler commercial quality, keyed like all other AJW cabinets.

**Collars:** Fabricated of #22 ga stainless steel, finished to match cabinet. (Used when full recessing cannot be accomplished)

**Overall Size:** 17 1/4"W x 54"H x 8 1/4"D  
**438mm x 1372mm x 210mm**

**Wall Opening:** 15 3/4"W x 52 1/2"H x 4"D  
**400mm x 1334mm x 102mm**

**U650-S2:** semi-recessed. with 2" collar, 2" wall opening 51mm

**U650-SM:** Full surface mounted collar.

**Towel Capacity:** 600 c-fold or 800 multifold

**Waste Capacity:** 12 gallons (1.6 cu ft)

**Options :**

**-VL1:** Vinyl Liner

### INSTALLATION

Coordinate installation with architect and contractor to avoid interference with pipes, vents, etc. Provide a rough wall opening 15 3/4"W x 52 1/2"H. See chart for required wall depth. If collar is required, slide collar over the back before installing into wall. Remove waste from cabinet and mount unit plumb and true in opening with proper fasteners per application. Secure waste in cabinet and load paper towels.

When cleaning cabinet use a non abrasive non-chloric solution and wiped off with the grain of the cabinet.

### NOTES



# U806

Toilet Tissue Dispenser

Revision 03/11

JOB #:

ITEM #:

QUANTITY:

MOUNTING	HANDING	TYPE	SIZE	OTHER

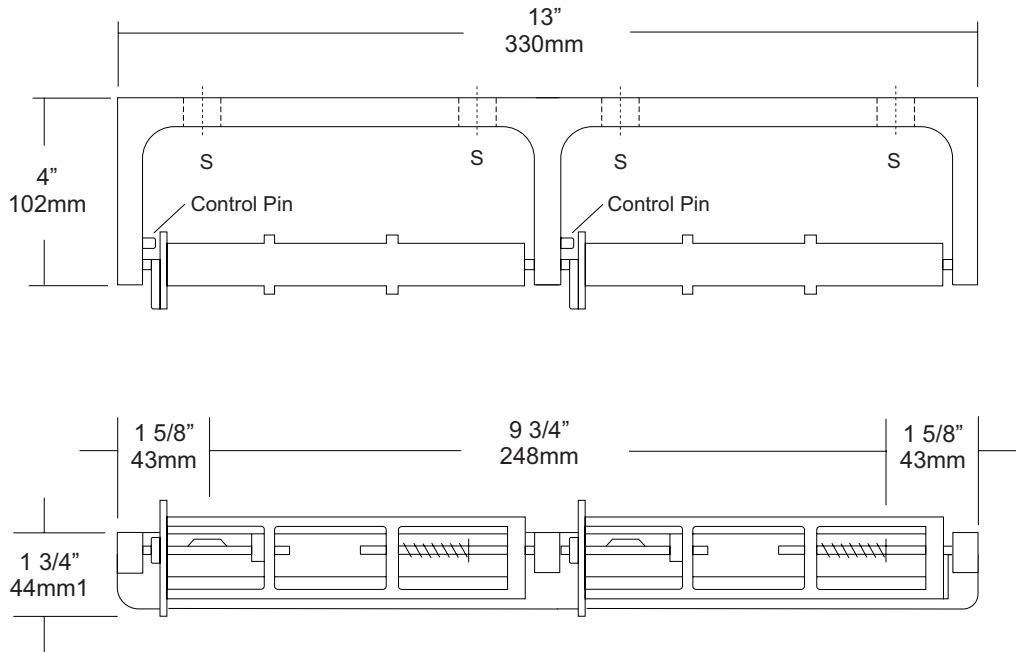

## SPECIFICATIONS

**Mounting Bracket:** Fabricated of heavy duty, die cast aluminum alloy, satin matte finish. One piece formed construction provides maximum strength and rigidity.

**Spindles:** Molded high impact ABS material (theft resistant) with stainless steel spring, designed to retain spindles on bracket. Spring loaded pin prevents roll from being removed until roll is depleted. Spindle rotates only 1/2 revolution.

**Control Pin:** Stainless steel pin provides dispenser a control delivery. On the -NC units (non-control) the pin is removed. This can be removed at the factory or in the field.

**Overall Size:** 13"W x 1 3/4"H x 4"D

**330mm x 45mm x 102mm**

**Capacity:** Two standard rolls with a 5 1/4" (133mm) OD.

**U806-NC:** Same as U806 with non-controlled delivery to comply with ADA code

## INSTALLATION

Provide an area on wall surface at desired or specified location. Place unit on mounting surface making sure unit is level and transfer mount points. Drill pilot holes and secure with proper fasteners per application. If a controlled delivery dispenser is installed, remove spring loaded pin to obtain a non-controlled delivery. All dispensers must have a non-control delivery, be mounted at the proper height and location to meet ADA code. (4.16)

## NOTES



# UG2-A

Grab Bars

Revised 03/11

JOB #:

ITEM #:

QUANTITY:

MOUNTING	HANDING	TYPE	SIZE	OTHER



## SPECIFICATIONS & INSTALLATION

**Tubing:** Fabricated of #18 ga stainless steel with a #4 satin finish. Available in 1 1/4" outside diameter. All bends are formed by an automatic mandrel bending process. All bars maintain a constant 1 1/2" offset.

**Finish:** Standard finish is a #4 satin finish. For a non-slip finish (peened) add suffix X to model number. (Ex. UG2X-A)

**Flanges:** Snap flanges are fabricated of 3" diameter, 3/8" deep drawn #22 ga stainless steel with #4 satin finish to match tubing. Flanges have dimples that secure over mounting plate.

**Strength:** Bars with a 1 1/2" offset clearance will support loads in excess of 900lbs when properly installed. Bars with greater offsets will support loads up to 250lbs when properly installed.

**Installation:** Before installing grab bars, verify with all state and local codes for requirements on bar diameter and type finish. Recommended mounting heights for grab bars are 33" - 36" centerline above finished floor. All mounting of grab bars when possible should have in wall mounting back plates. Find centerline mounting points and place bar on line making sure to be on center. Transfer mounting points (3 per flange) to wall. Drill pilot holes and secure bar with proper anchors per application. Snap cover over mounting plate.

**Standard Lengths (Other sizes available upon request):** 12", 16", 18", 24", 30", 32", 36", 42", 48", 50", 52", 54", 56"

## FLANGE INFORMATION

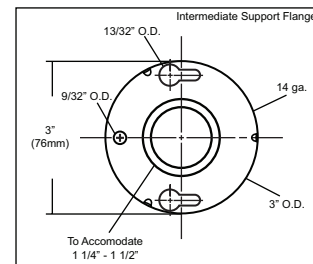
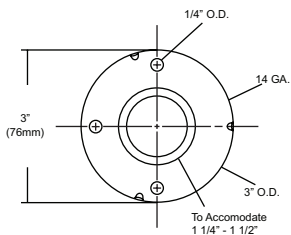
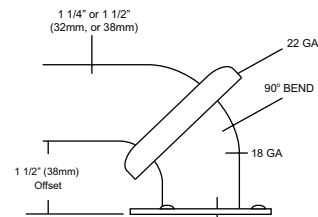

## NOTES