

date	11-1-17
projectname	3217
attn	Tiffany
from	Tiffany
fax	5183700769
email	planroom@gdarc.com
phone	5183700767



# UX1-B-CV

Flange & Curved Shower Rod

Revision 03/12

JOB #:

ITEM #:

QUANTITY:

MOUNTING	HANDING	TYPE	SIZE	OTHER

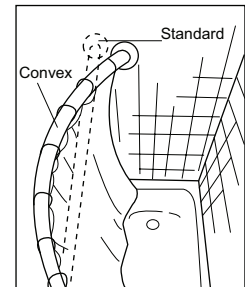
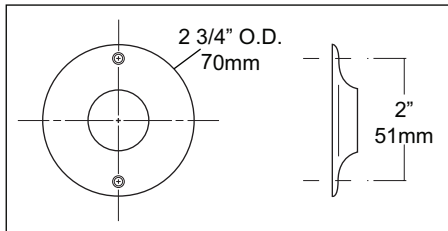
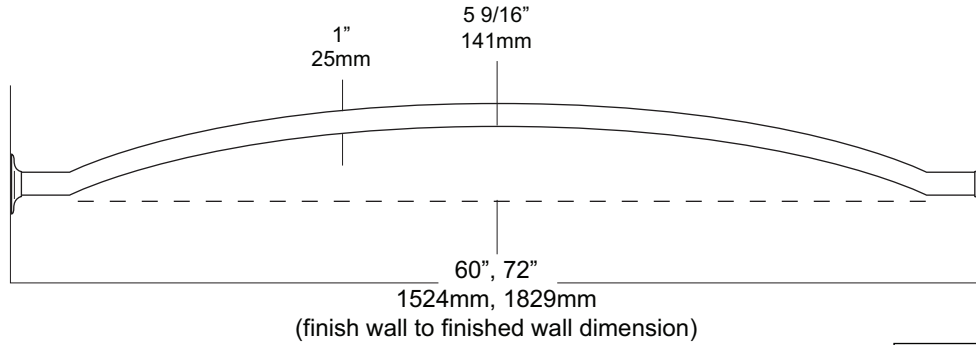

### SPECIFICATIONS

**Rods:** Fabricated of #18 ga stainless steel with a #4 satin finish with a 1" outside diameter. Rod configuration is accomplished by a roll former that provides an additional 5 9/16" showering area. (Aprx. 25%)

**Flanges:** 22 ga. exposed mounting stainless steel flanges have a #4 satin finish to match rod. One flange is permanently secured to the rod, the other is loose for mounting purposes. 72"L is the maximum recommended size for this style rod. Overhead supports are not required for this style rod.

**Overall Size:** 1" O.D.

**Standard Sizes:** 60", 72"

### INSTALLATION

Provide an area on wall surface at desired or specified location. Hold flange to wall surface and transfer mounting points. Drill pilot holes. Place flanges on the ends of the rods. Secure flanges to wall surface with proper fasteners per application. Make sure the shower rod is level before securing.

### NOTES

Formerly Model #: UCVS



# UX1-J-CV

Flange & Curved Shower Rod

Revision 03/11

JOB #:

ITEM #:

QUANTITY:

MOUNTING	HANDING	TYPE	SIZE	OTHER

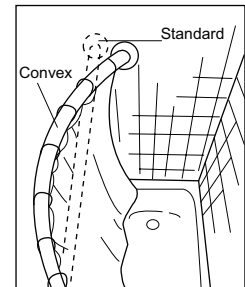
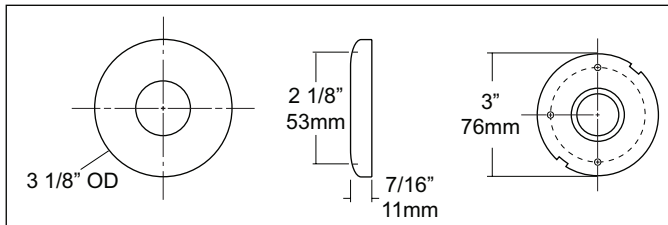
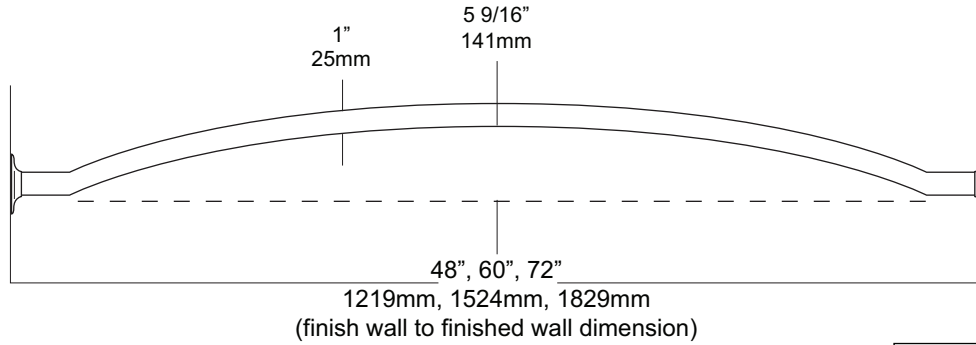

### SPECIFICATIONS

**Rods:** Fabricated of stainless steel with a #4 satin finish. Rod configuration is accomplished by a roll former that provides additional

**5 9/16" showering area. (approx. 25%)**

**Flanges:** Concealed snap on flange with a #4 satin finish. One mounting plate is welded to the rod, the other is loose for mounting purposes. 72"L is the maximum recommended size for this style rod. Overhead supports are not required for this style rod.

**Standard Sizes:** 48", 60", 72"

### INSTALLATION

Provide an area on wall surface at desired or specified location. Hold flange to wall surface and transfer mounting points. Drill pilot holes. Place flanges on the ends of the rods. Secure flanges to wall surface with proper fasteners per application. Make sure the shower rod is level before securing.

### NOTES



# UX1-V Overhead Supports

Revision 03/11

JOB #:

ITEM #:

QUANTITY:

MOUNTING	HANDING	TYPE	SIZE	OTHER

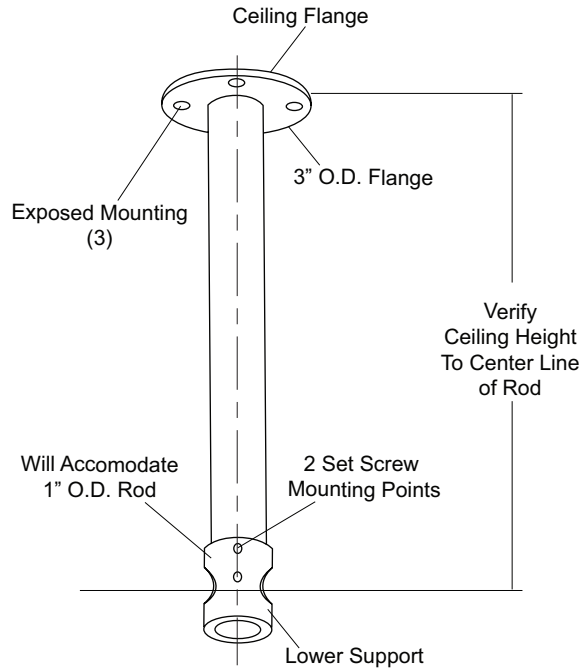

### SPECIFICATIONS

- Rod:** Fabricated of #18 gauge stainless steel tube with a #4 satin finish.
- Flange:** Ceiling mounted exposed flange has a 3" O.D. With three exposed mounting points.
- Support:** Machined aluminum with a satin finish. Unit will accommodate 1" OD shower rod
- UX1-V:** 1"OD

### INSTALLATION

Provide an area on ceiling at desired or specified location. Transfer mounting points and drill pilot holes. Secure flange with proper fasteners per each application. Slide lower support over vertical rod end and secure with supplied set screw. Do not finish securing support to rod to make adjustments. Slide shower rod through support opening and secure to rod flanges. After shower rod is secured to flanges and checks to be level finish securing rod and support with supplied set screws (2). Recommend overhead supports for all rods over 72" and other configurations than straight runs.

### NOTES

Formerly Model #: UX168



**UX169**  
Shower Curtain Hooks

Revision 03/11

JOB #:

ITEM #:

QUANTITY:

MOUNTING	HANDING	TYPE	SIZE	OTHER

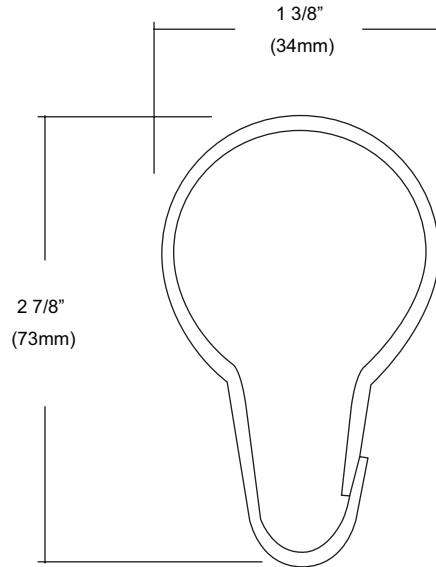

**SPECIFICATIONS**

Unit is constructed of stainless steel. Ring snaps around the shower rod to support curtain. Spacing of hooks is every 6" and can be installed on both 1" & 1 1/4" diameter rods.

Overall Size: 1 3/8"W x 2 7/8

34mm x 73mm

**INSTALLATION**

Thread hook through curtain eyelet. Slide rings onto curtain rod. Hook can accommodate 1" & 1 1/4" rods.

**NOTES**



**UX171**  
Shower Curtain Hooks with Rollers

Revision 05/14

JOB #:

ITEM #:

QUANTITY:

MOUNTING	HANDING	TYPE	SIZE	OTHER

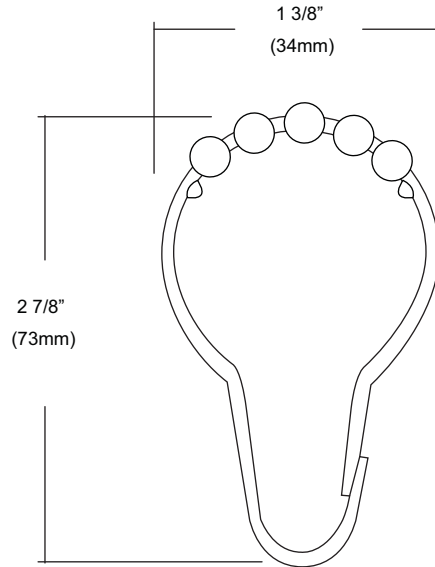

**SPECIFICATIONS**

Unit is constructed of chrome plated steel. Ring snaps around the shower rod to support curtain. Spacing of hooks is every 6" and can be installed on both 1" & 1 1/4" diameter rods.

Overall Size: 1 3/8"W x 2 7/8

34mm x 73mm

**INSTALLATION**

Thread hook through curtain eyelet. Slide rings onto curtain rod. Hook can accommodate 1" & 1 1/4" rods.

**NOTES**

**UX1A**  
Flange & Shower Rod

Revision 03/11

JOB #:

ITEM #:

QUANTITY:

MOUNTING	HANDING	TYPE	SIZE	OTHER

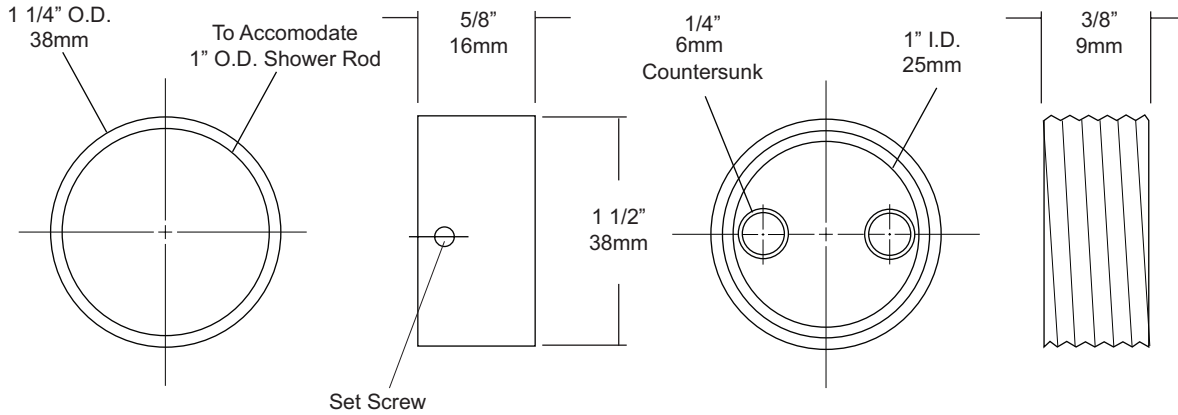

**SPECIFICATIONS**

**Cover:** Fabricated of chrome on brass, with concealed mounting. One flange of the pair is equipped with a set screw to prevent rod from rotating.  
**Shower Rod:** Fabricated of 18 gauge stainless steel with a #4 satin finish.  
**UX1:** 1" outside diameter

**INSTALLATION**

Provide an area on wall surface at desired or specified location. Hold flange to wall surface and transfer mounting points. Drill pilot holes. Place flanges on the ends of the rods. Secure flanges to wall surface with proper fasteners per application.

**NOTES**



**UX1B**  
Flange & Shower Rod

Revision 03/11

JOB #:

ITEM #:

QUANTITY:

MOUNTING	HANDING	TYPE	SIZE	OTHER

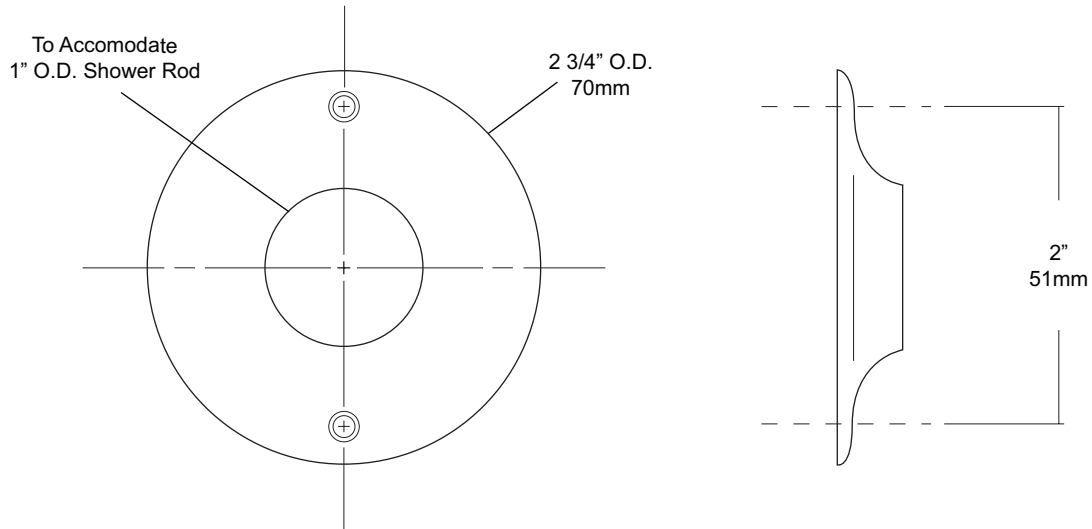

**SPECIFICATIONS**

**Exposed Cover:** Fabricated of #22 gauge stainless steel with a #4 satin finish. Cover has 2 (2) exposed mounting points.  
**Shower Rod:** Fabricated of 18 gauge stainless steel with a #4 satin finish.  
**UX1:** 1" outside diameter

**INSTALLATION**

Provide an area on wall surface at desired or specified location. Hold flange to wall surface and transfer mounting points. Drill pilot holes. Place flanges on the ends of the rods. Secure flanges to wall surface with proper fasteners per application.

**NOTES**





# UX1C

Flange & Shower Rod

Revision 03/11

JOB #:

ITEM #:

QUANTITY:

MOUNTING	HANDING	TYPE	SIZE	OTHER

To Accomodate  
1" O.D. Shower Rod

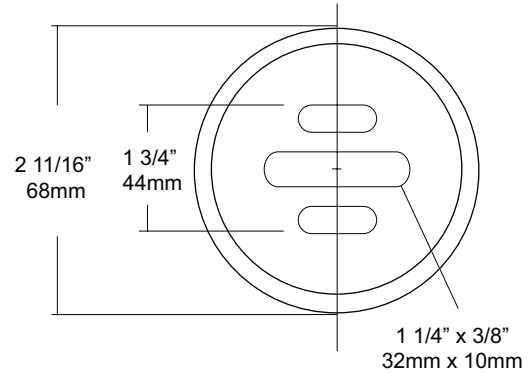
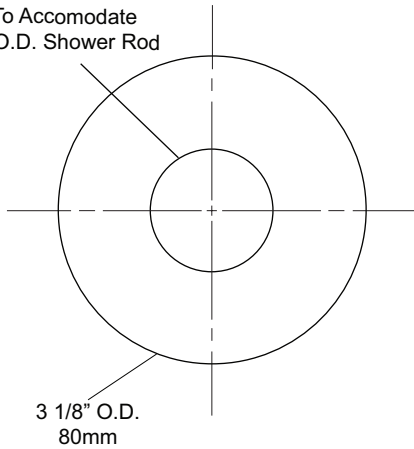

### SPECIFICATIONS

**Set Screw Cover:** Fabricated of #11 gauge stainless steel with a #4 satin finish, secured with four (4) set screws.

**Flanges:** Fabricated of 3" diameter, 1/2" drawn #11 ga stainless steel with #4 satin finish to match tubing. Flanges are heliarc welded to bar to form a one piece construction. Each flange is secured to concealed mounting plate with four (4) 1/4"-20 stainless steel tamper resistant set screws.

**Shower Rod:** Fabricated of 18 gauge stainless steel with a #4 satin finish.

**UX1:** 1" outside diameter

### INSTALLATION

Provide an area on wall surface at desired or specified location. Hold flange to wall surface and transfer mounting points. Drill pilot holes. Place flanges on the ends of the rods. Secure flanges to wall surface with proper fasteners per application.

### NOTES



# UX1E

Flange & Shower Rod

Revision 03/11

JOB #:

ITEM #:

QUANTITY:

MOUNTING	HANDING	TYPE	SIZE	OTHER

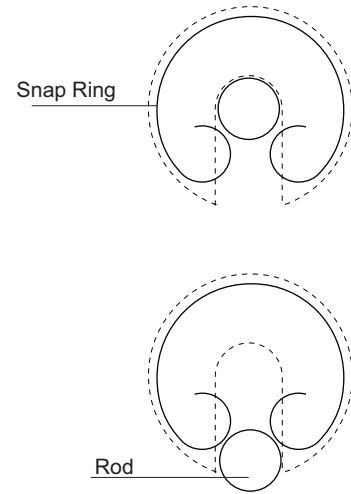
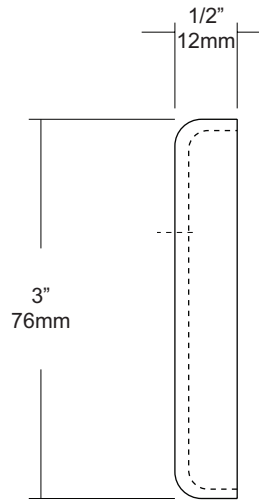
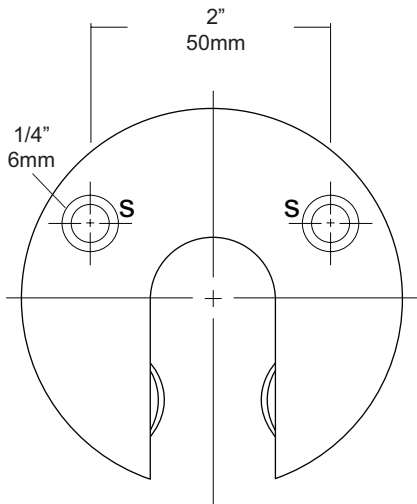

### SPECIFICATIONS

**Exposed Cover:** Fabricated of #11 gauge stainless steel with a #4 satin finish. Cover has 2 (2) exposed mounting points. Retention spring has an approximate load capacity of 35lbs. When excess of 35lbs is applied, shower rod will separate from cover.

**Shower Rod:** Fabricated of 18 gauge stainless steel with a #4 satin finish.

**UX1:** 1" outside diameter

### INSTALLATION

Provide an area on wall surface at desired or specified location. Hold flange to wall surface and transfer mounting points. Drill pilot holes. Place flanges on the ends of the rods. Secure flanges to wall surface with proper fasteners per application.

### NOTES

## UX1J

Flange & Shower Rod

Revision 11/11

JOB #:

ITEM #:

QUANTITY:

MOUNTING	HANDING	TYPE	SIZE	OTHER

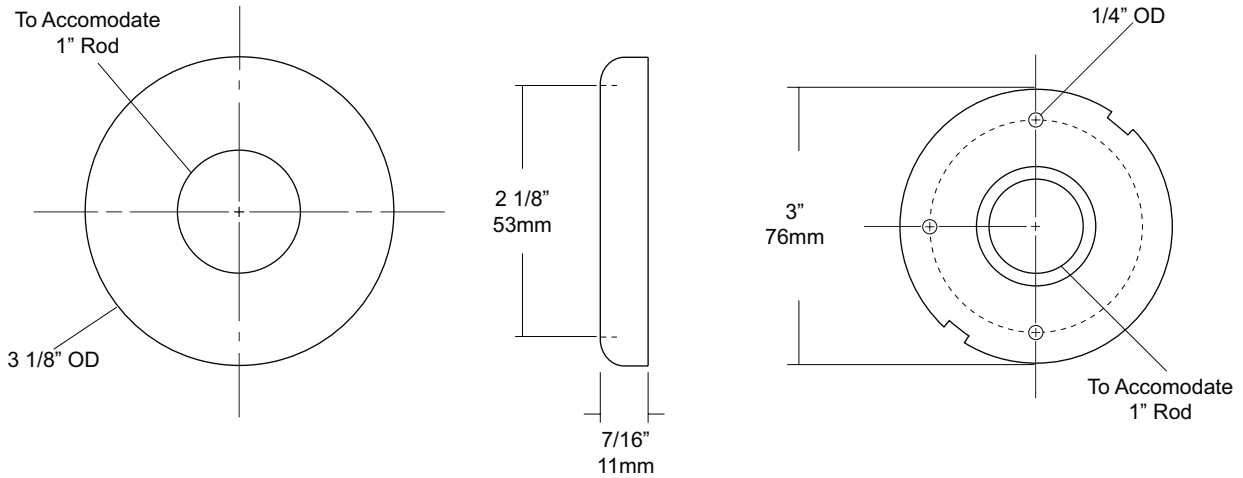

### SPECIFICATIONS

**Concealed Mounting Plate:** #14 gauge stainless steel with three (3) mounting points to secure to mounting surface and three (3) dimples that secure snap cover escutcheon.

**Snap Cover:** Fabricated of #22 gauge stainless steel with a #4 satin finish. Cover snaps over mounting plate to provide a concealed mounting application.

**Shower Rod:** Fabricated of 18 gauge stainless steel with a #4 satin finish.

**UX1:** 1" outside diameter

### INSTALLATION

Provide an area on wall surface at desired or specified location. Hold flange to wall surface and transfer mounting points. Drill pilot holes. Place flanges on the ends of the rods. Secure flanges to wall surface with proper fasteners per application.

### NOTES

**UX1K**  
 Flange & Shower Rod

Revision 03/11

JOB #:

ITEM #:

QUANTITY:

MOUNTING	HANDING	TYPE	SIZE	OTHER

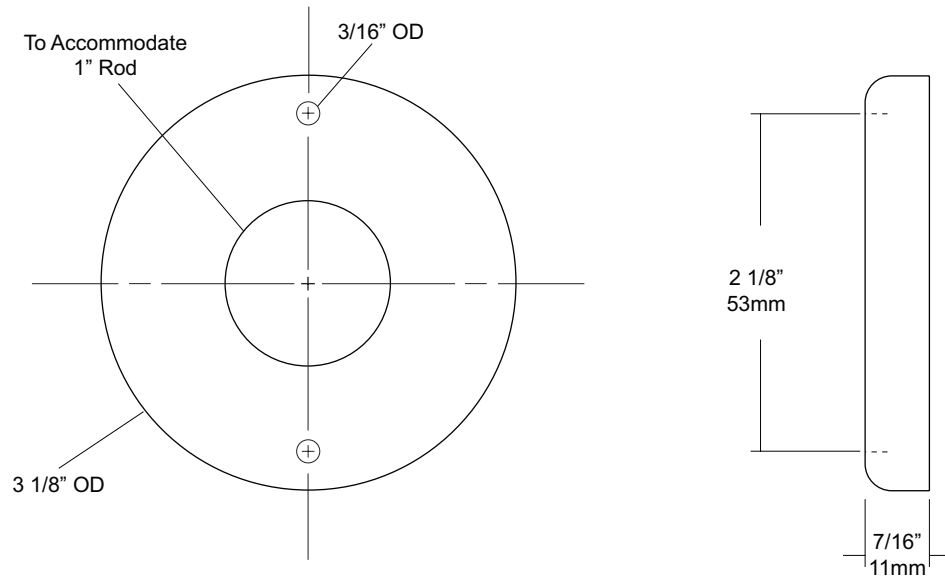

**SPECIFICATIONS**

**Exposed Cover:** Fabricated of #22 gauge stainless steel with a #4 satin finish. Cover has two (2) exposed mounting points.  
**Shower Rod:** Fabricated of 18 gauge stainless steel with a #4 satin finish.  
**UX1:** 1" outside diameter

**INSTALLATION**

Provide an area on wall surface at desired or specified location. Hold flange to wall surface and transfer mounting points. Drill pilot holes. Place flanges on the ends of the rods. Secure flanges to wall surface with proper fasteners per application.

**NOTES**

**UX2-V**  
Overhead Supports

Revision 03/11

JOB #:

ITEM #:

QUANTITY:

MOUNTING	HANDING	TYPE	SIZE	OTHER

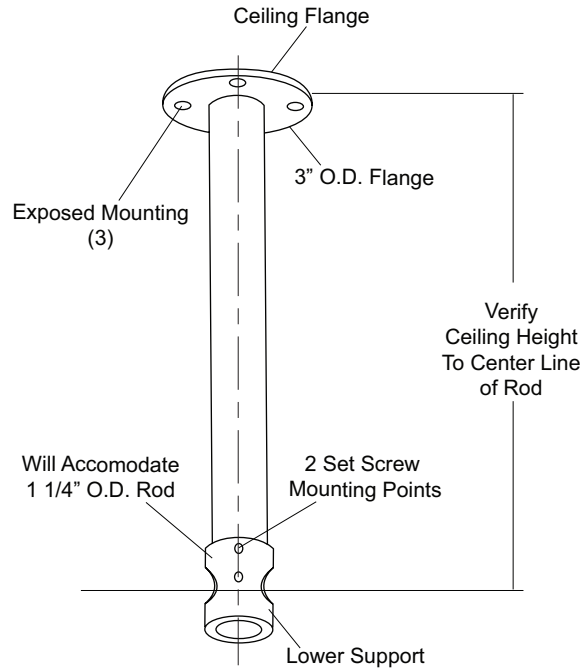

**SPECIFICATIONS**

**Rod:** Fabricated of #18 gauge stainless steel tube with a #4 satin finish.  
**Flange:** Ceiling mounted exposed flange has a 3" O.D. With three exposed mounting points.  
**Support:** Machined aluminum with a satin finish. Unit will accommodate 1 1/4"OD shower rod  
**UX2-V:** 1 1/4"OD

**INSTALLATION**

Provide an area on ceiling at desired or specified location. Transfer mounting points and drill pilot holes. Secure flange with proper fasteners per each application. Slide lower support over vertical rod end and secure with supplied set screw. Do not finish securing support to rod to make adjustments. Slide shower rod through support opening and secure to rod flanges. After shower rod is secured to flanges and checks to be level finish securing rod and support with supplied set screws (2). Recommend overhead supports for all rods over 72" and other configurations than straight runs.

**NOTES**

Formerly Model #: UX168A

## UX2A

Flange & Shower Rod

Revision 03/11

JOB #:

ITEM #:

QUANTITY:

MOUNTING	HANDING	TYPE	SIZE	OTHER

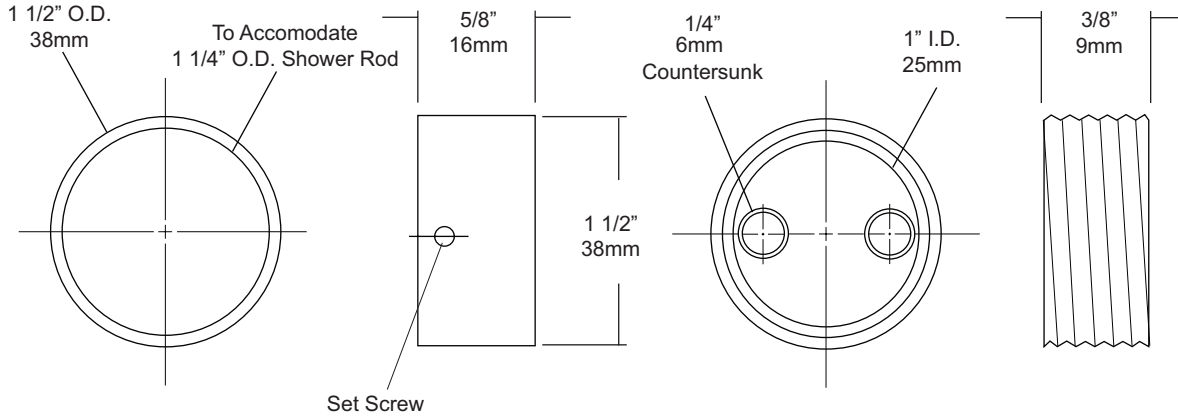

### SPECIFICATIONS

**Cover:** Fabricated of chrome on brass, with concealed mounting. One flange of the pair is equipped with a set screw to prevent rod from rotating.  
**Shower Rod:** Fabricated of 18 gauge stainless steel with a #4 satin finish.  
**UX1:** 1 1/4" outside diameter

### INSTALLATION

**Measuring Curtains:** Curtains are measured W x H. The same curtain will fit a 1 or 1 1/4" diameter rod.

### NOTES



# UX2B

## Flange & Shower Rod

Revision 03/11

JOB #:

ITEM #:

QUANTITY:

MOUNTING	HANDING	TYPE	SIZE	OTHER

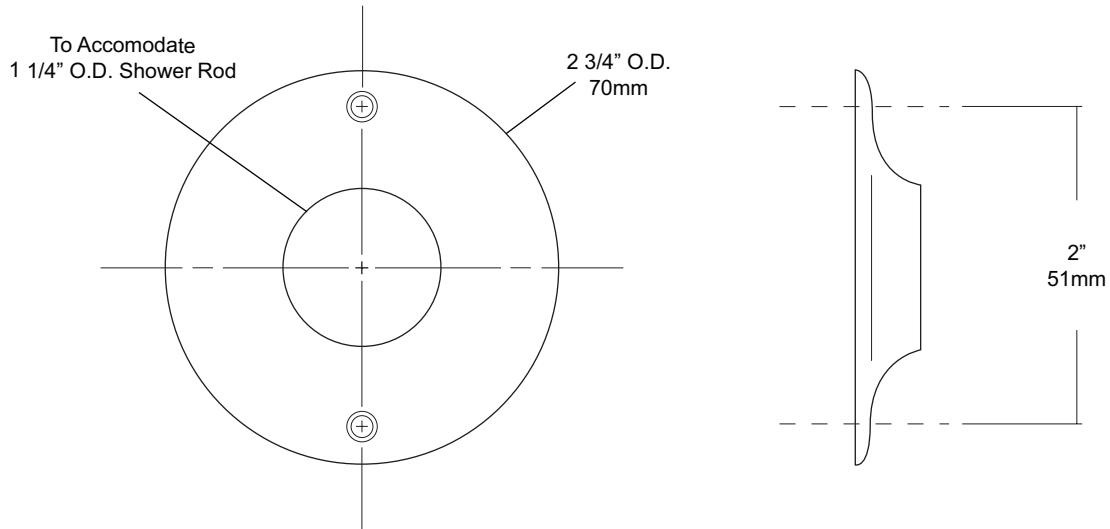

SPECIFICATIONS	INSTALLATION
----------------	--------------

<p><b>Exposed Cover:</b> Fabricated of #22 gauge stainless steel with a #4 satin finish. Cover has 2 (2) exposed mounting points.</p> <p><b>Shower Rod:</b> Fabricated of 18 gauge stainless steel with a #4 satin finish.</p> <p><b>UX2:</b> 1 1/4" outside diameter</p>	<p>Provide an area on wall surface at desired or specified location. Hold flange to wall surface and transfer mounting points. Drill pilot holes. Place flanges on the ends of the rods. Secure flanges to wall surface with proper fasteners per application.</p>
<b>NOTES</b>	

## UX2C

Flange & Shower Rod

Revision 03/11

JOB #:

ITEM #:

QUANTITY:

MOUNTING	HANDING	TYPE	SIZE	OTHER

To Accomodate  
1 1/4" O.D. Shower Rod

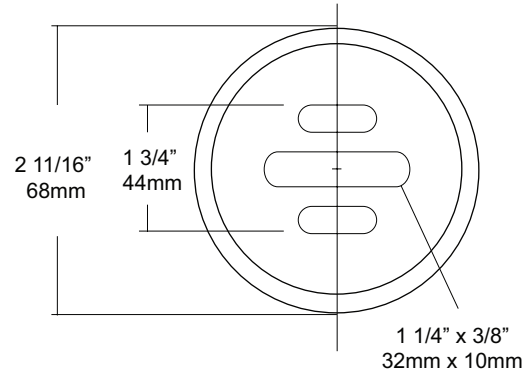
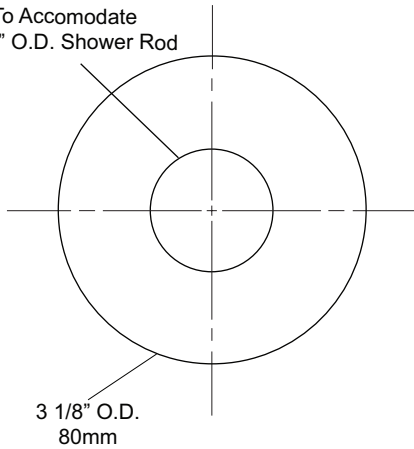

### SPECIFICATIONS

**Set Screw Cover:** Fabricated of #11 gauge stainless steel with a #4 satin finish, secured with four (4) set screws.

**Flanges:** Fabricated of 3" diameter, 1/2" drawn #11 ga stainless steel with #4 satin finish to match tubing. Flanges are heliarc welded to bar to form a one piece construction. Each flange is secured to concealed mounting plate with four (4) 1/4"-20 stainless steel tamper resistant set screws.

**Shower Rod:** Fabricated of 18 gauge stainless steel with a #4 satin finish.

**UX2:** 1 1/4" outside diameter

### INSTALLATION

Provide an area on wall surface at desired or specified location. Hold flange to wall surface and transfer mounting points. Drill pilot holes. Place flanges on the ends of the rods. Secure flanges to wall surface with proper fasteners per application.

### NOTES





# UX2J

Flange & Shower Rod

Revision 11/11

JOB #:

ITEM #:

QUANTITY:

MOUNTING	HANDING	TYPE	SIZE	OTHER

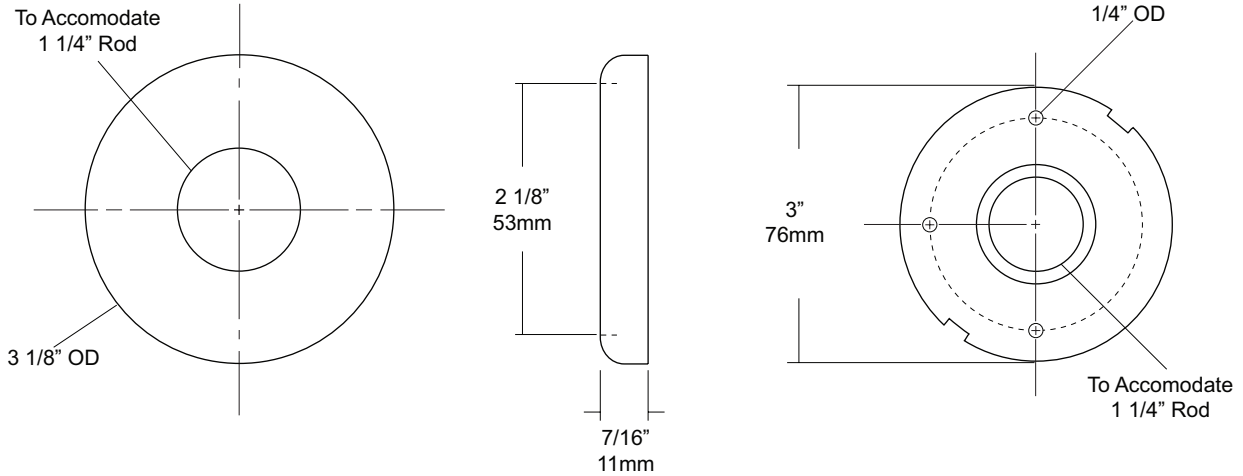

### SPECIFICATIONS

**Concealed Mounting Plate:** #14 gauge stainless steel with three (3) mounting points to secure to mounting surface and three (3) dimples that secure snap cover escutcheon.

**Snap Cover:** Fabricated of #22 gauge stainless steel with a #4 satin finish. Cover snaps over mounting plate to provide a concealed mounting application.

**Shower Rod:** Fabricated of 18 gauge stainless steel with a #4 satin finish.

**UX2:** 1 1/4" outside diameter

### INSTALLATION

Provide an area on wall surface at desired or specified location. Hold flange to wall surface and transfer mounting points. Drill pilot holes. Place flanges on the ends of the rods. Secure flanges to wall surface with proper fasteners per application.

### NOTES



**UX2K**  
Flange & Shower Rod

Revision 03/11

JOB #:

ITEM #:

QUANTITY:

MOUNTING	HANDING	TYPE	SIZE	OTHER

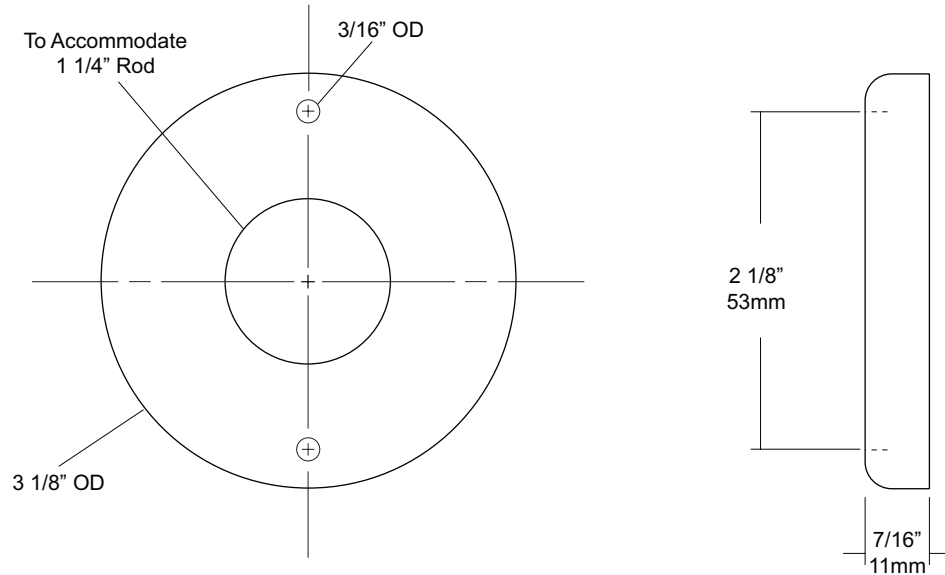

**SPECIFICATIONS**

**Exposed Cover:** Fabricated of #22 gauge stainless steel with a #4 satin finish. Cover has two (2) exposed mounting points.

**Shower Rod:** Fabricated of stainless steel with a #4 satin finish.

**UX2:** 1 1/4" outside diameter

**INSTALLATION**

Provide an area on wall surface at desired or specified location. Hold flange to wall surface and transfer mounting points. Drill pilot holes. Place flanges on the ends of the rods. Secure flanges to wall surface with proper fasteners per application.

**NOTES**