

date  
projectname  
attn  
from  
fax  
email  
phone

11/22/2019  
SOF TORII  
Toshimi  
Toshimi  
toshimi@pacrimbuilding.com  
425-251-3700



# U126 Soap Dispenser

Revision 11/14

JOB #:

ITEM #:

QUANTITY:

MOUNTING	HANDING	TYPE	SIZE	OTHER



## SPECIFICATIONS

**Soap Tank:** Fabricated of #20 ga stainless steel, #4 satin finish, fully welded one-piece construction.

**Valve:** All purpose antibacterial soap valve cylinder, black molded plastic push style valve that takes less than 5 lbs of force and one hand to operate complies with barrier free guidelines when mounted at proper height.

**Viewer:** Clear plastic window allows a constant fluid level check.

**Concealed Mounting Plate:** Fabricated of heavy gauge stainless steel.

**Filler Cap:** Fabricated of stainless steel, hinged to allow easy servicing, secured with special key that creates a vandal resistant dispenser.

**Overall Size:** 4 3/4"W x 8 1/4"H x 3 3/4"D (wall to valve)  
**121mm x 210mm x 95mm**

**Capacity:** 40 oz.

**Recommend type soaps without chloric solutions for proper operation.**

## INSTALLATION

Provide an area on mounting surface at desired or specified location. Secure concealed mounting plate to wall surface with proper fasteners. Slide dispenser down over mounting plate and secure by means of set screw located inside tank. Fill unit with proper soap. Close lid and secure with special key. Test valve for proper operation.

\*It is not recommended to mount any soap dispenser on mirrors

\*\*For best performance, use pre-mixed low concentrate solutions. Dispensers should have periodic maintenance performed to insure the life dispenser. Rinse out globe and valve with warm water to avoid sludge buildup.

Preventative Maintenance: Each dispenser should be flushed out aprx. Every 30 days with warm water to prevent valve from clogging with old soap. Do not use abrasive cleaners to clean dispenser.

## NOTES



# U1525EA Series

White Hands Free Dryer

Revision 12/14

JOB #:

ITEM #:

QUANTITY:

MOUNTING	HANDING	TYPE	SIZE	OTHER
----------	---------	------	------	-------

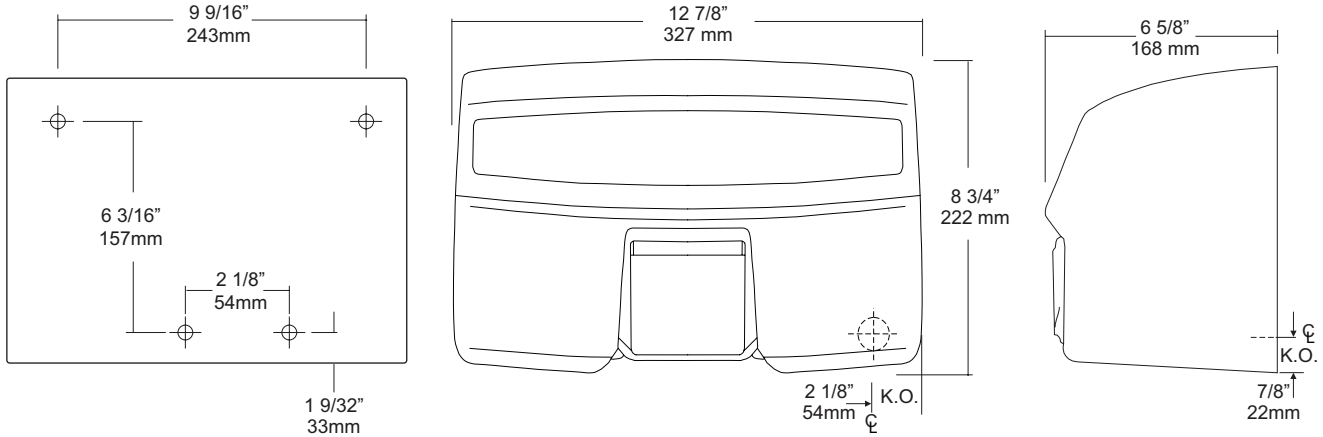

## SPECIFICATIONS

**Motor:** Brushless 3450 RPM, 1/8 hp motor, capacitor initiated, thermally protected against overheating. 66.1 dB.

**Fan:** Dynamically balanced to eliminate vibration/noise.

**Heating Element:** 2300 watt nichrome wire, mounted on state of the art convective heating injection system mounted to blower housing, protected by integral safety circuit breaker.

**Timer:** Fully enclosed electronic timer that automatically turns off when hands are moved away from path of sensor.

**Electric Eye:** Sensor allows a hands free operation. When sensor beam path is disturbed, dryer will automatically turn on. When hands are moved away from beam, dryer stops.

**Cover:** Heavy die cast aluminum with baked white enamel finish and ribbed for added strength. Secured to base with two theft resistant fasteners. Chrome plated nozzle can be fixed or two position.

**Base:** One piece #14 ga steel with 3/4" returns to wall for maximum strength and rigidity.

Unit	Volts	Amps	Cycles
U1525EA	120V	110-120	20 60
U1525EA	230V	208-230	10 60

**Overall Size:** 12 7/8"W x 8 3/4"H x 6 5/8"D  
327mm x 222mm x 168mm

## INSTALLATION

Coordinate installation with contractor, architect and licensed electrician. Transfer mounting points to wall surface with supplied template. Check all code requirements for proper mounting heights. Secure base to surface with proper fasteners per application. Properly connect power supply to dryer and test operation. Secure dryer to base and test dryer again after cover is secured. Recommend 1 dryer per basin. Dryers have a full five (5) year warranty to original purchaser against defective materials and workmanship. Unit must be installed by a licensed electrician.

Mounting	Hands	Hair
Men	46" (1168mm)	73" (1854mm)
Women	44" (1118mm)	68" (1727mm)
Physically Impaired	38" (965mm)	46" (1168mm)
Children 6-10	34" (864mm)	43" (1092mm)
Children 11-14	42" (1067mm)	56" (1422mm)

\*Above are recommended mounting heights from lower mounting point above the finished floor.

## NOTES

Formerly Model #: U1525EA





# U627

## Folded Towel & Waste Combination Unit

Revision 03/11

JOB #:

ITEM #:

QUANTITY:

MOUNTING	HANDING	TYPE	SIZE	OTHER

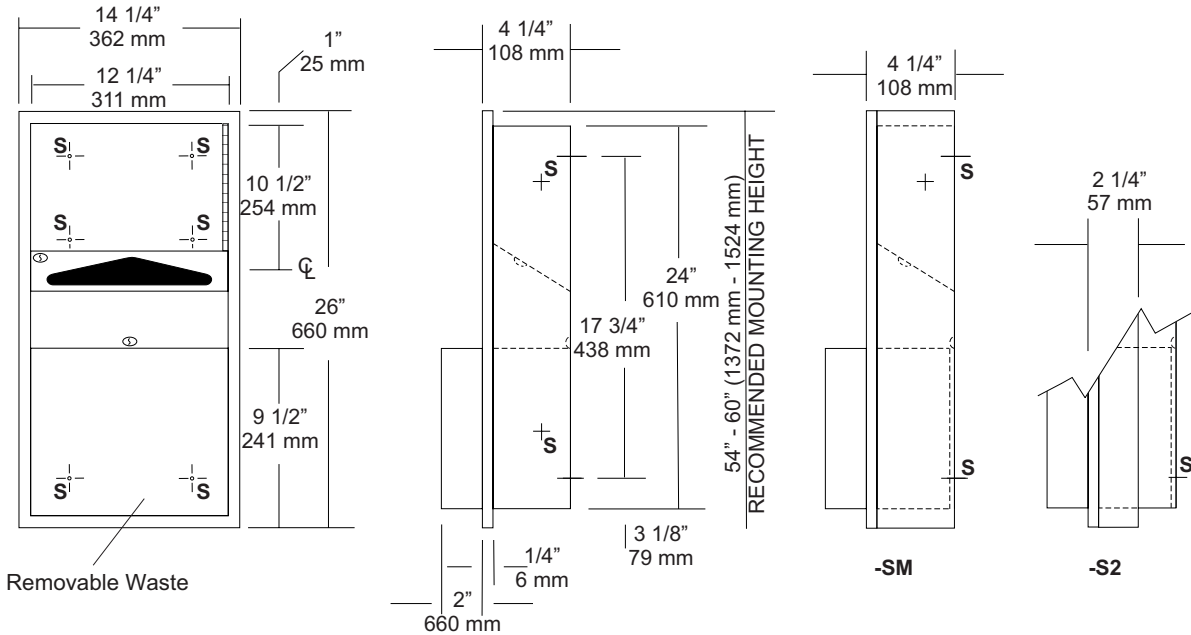

SPECIFICATIONS	INSTALLATION
----------------	--------------

**Body:** Fabricated of #22 ga stainless steel with a #4 satin finish.

**Flange:** Fabricated of #22 ga stainless steel with #4 satin finish and 1/4" returns to wall. (No miters or welds)

**Cabinet Back:** Fabricated of stainless steel formed for rigidity with multiple welds to cabinet body.

**Cabinet Door:** Fabricated of #22 ga stainless steel with #4 satin finish with full length door stop to prevent vandalism

**Towel Dispenser:** Dispensing area has hemmed edges to prevent injury and towel tearing.

**Removable Waste:** Fabricated of #22 ga stainless steel removable waste with radius and hemmed edges. Waste is secured by means of a pin tumbler lock with embossed tabs for liners.

**Hinges:** Heavy duty, full length, stainless steel piano type hinge.

**Lock:** Pin tumbler commercial quality keyed like all other AJW cabinets.

**Collars:** Fabricated of #22 ga #4 satin finish stainless steel finished to match cabinet body.

**Overall Size:** 14 1/4"W x 26"H x 6 1/4"D  
**362mm x 660mm x 159mm**

**Wall Opening:** 12 3/4"W x 24 1/2"H x 4"D  
**324mm x 622mm x 102mm**

**U627-S2:** Semi-recessed with 2" collar, 2" wall open. 51mm.

**U627-SM:** Surface mounted

**Towel Capacity:** 350 c-fold or 475 multifold

**Waste Capacity:** 2.65 gallons (.38 cu ft)

**Options:**  
**-VL3:** Reusable vinyl liner.

Coordinate installation with contractor and architect to avoid interference with pipes vents etc. Provide a rough wall opening 12 3/4"W x 24 1/2"H. Wall opening depth will depend on style mounting. Remove waste in install unit in opening. Make sure cabinet will sit flush in wall and secure with proper fasteners per application. Secure waste back into cabinet and load paper towels.

When cleaning cabinet, use a soft cloth, a non-abrasive or chloric solutions.

**NOTES**

JOB #:

ITEM #:

QUANTITY:

MOUNTING	HANDING	TYPE	SIZE	OTHER

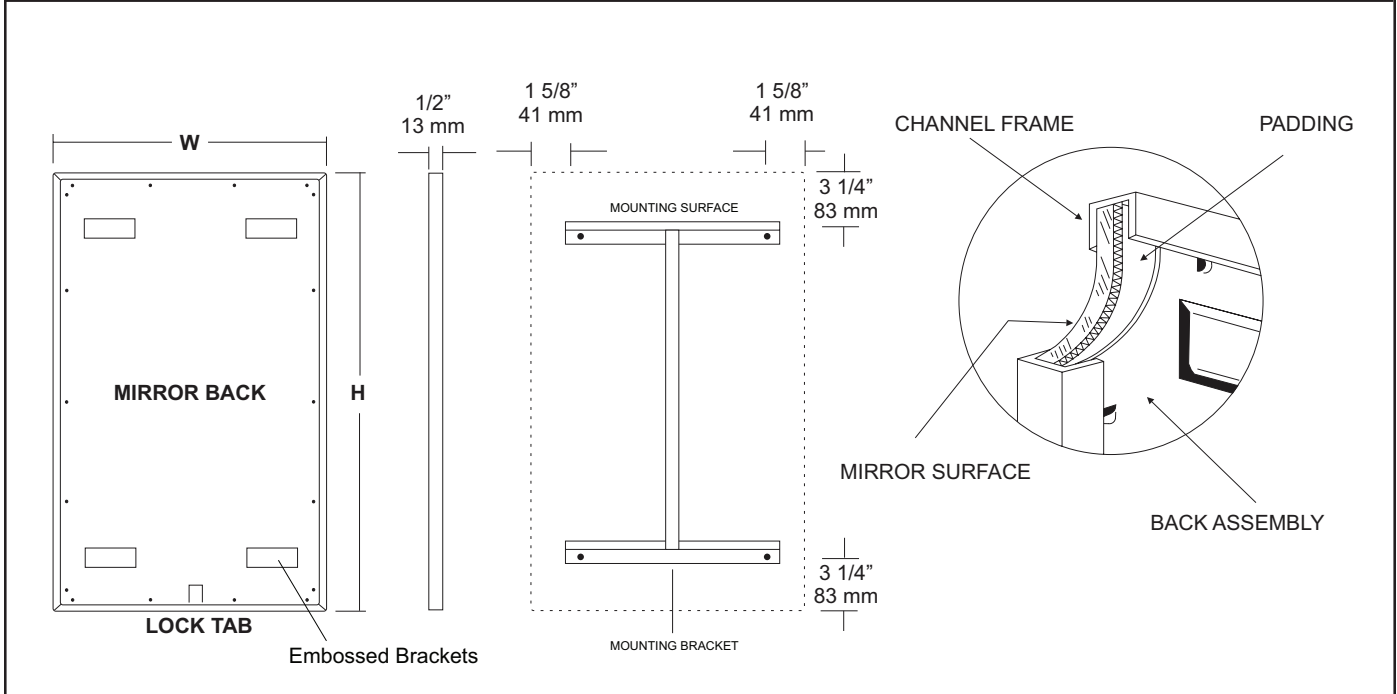

#### SPECIFICATIONS

**Frame:** Fabricated of #20 ga stainless steel, #4 satin finish. Roll formed 1/2" x 1/2" x 1/2" channel frame has mitered corners and secured with stainless steel rivet.

**Mirror:** 1/4" thick type 1 transparent flat type, class 1 - clear glass mirrors. Mirror is coated with silver and sealed with a uniform electrolytic copper plating, along with two coats of paint for added protection. Mirrors are guaranteed against silver spoilage for a period of 15 years. Mirrors conform to ASTM C1036 and ASTM C1503-R8.

**Filler:** Full size, 1/8" shock absorbing, water resistant, nonabrasive, polyethylene padding protects all concealed mirror surfaces.

**Back:** #20 ga pre-plated galvanized steel, with embossed horizontal louver mounting brackets. Embossed theft resistant pressure activated clip lock device, locks mirror in place to wall hangers.

**Hangers:** Fabricated of #20 ga pre-plated steel galvanized steel with mounting points.

**Standard Sizes Available (W x H):** 16"x20", 16"x24", 16"x30", 18"x24", 18"x30", 18"x36", 24"x30", 24"x36", 24"x42", 24"x48", 18"x60", 20"x60", 24"x60", 18"x72", 24"x72"

#### Options:

- LG:** Laminated Glass
- LX:** Polycarbonate
- PM:** Plastic Acrylic
- T:** Tempered Glass
- VC:** Vinyl Clad (Safety Glass)
- 8B:** #8 Reflective Stainless Steel

\*Stainless steel mirrors reflect images in different optic quality than plate glass. There will be a slight distortion which increases proportionately with the mirror size. Therefore, AJW Architectural Products™ cannot be held responsible for quality of image.

- \*\*Mirrors are always ordered Width x Height
- \*\*\*Recommended max size for 8B mirrors: 72" x 47-1/2"
- \*\*\*\*Framed mirrors are fabricated to a tolerance of (+/-) 1/8"
- \*\*\*\*\* Mirrors conform to Federal Specifications DD-M-00411b & DD-g-541D

#### INSTALLATION

Coordinate installation with architect / contractor for specific mounting location and height for each mirror application. Making sure "I" bracket is level, transfer all mounting point locations to wall surface from drawing. Secure brackets with proper fasteners for each application. Slide mirror down over horizontal brackets until clip lock secures mirror in place. Mirror can only be removed by inserting tool through hole at bottom of frame depressing clip. This will allow mirror to slide up over brackets. Fillers are available if mirrors are mounted above and below tile line. (U004 Filler) filler material will match mirror frame to form a one piece construction.

To meet ADA Code, bottom edge of reflective surface can be no higher than 40" above finished floor. (4.19.6) Full length mirrors may be used for universal application when installed in correct locations.

Abrasive cleaners & chloric solutions should not be used on mirrors. Discoloring and /or scratching of frame and reflective surface may occur.

#### NOTES



# U840 Toilet Tissue Dispenser

Revision 03/11

JOB #:

ITEM #:

QUANTITY:

MOUNTING	HANDING	TYPE	SIZE	OTHER

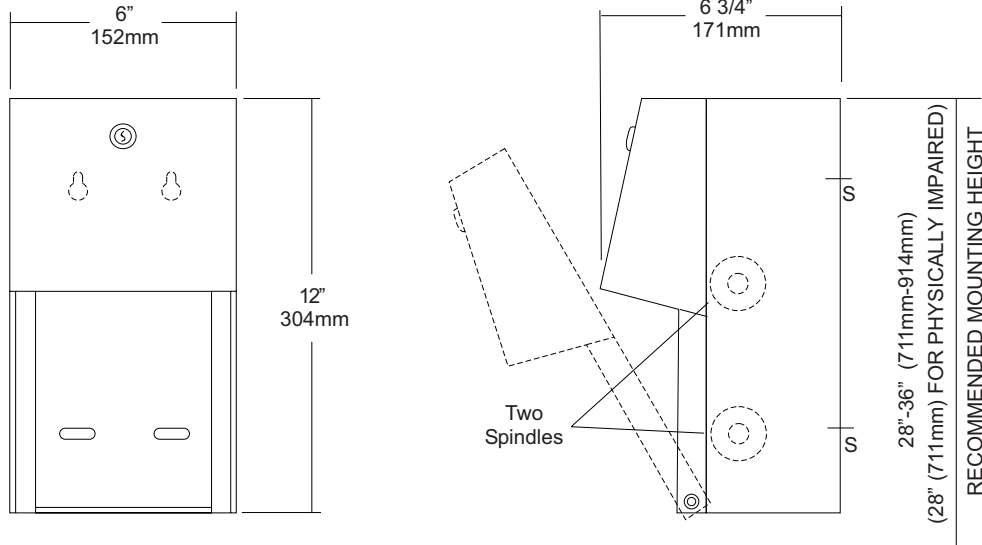

### SPECIFICATIONS

- Body:** Fabricated of #22 ga stainless steel with #4 satin finish. Concealed inner dispensing mechanism is #18 ga stainless steel.
- Back:** Fabricated of #18 ga stainless steel with multiple welds to cabinet body forming a one piece construction.
- Hood:** Fabricated of #18 ga stainless steel finished to match cabinet body. Hood is secured with stainless steel hinge rivets to cabinet body. Top roll of tissue will not drop down unless the bottom roll has been depleted. When unit is closed, this will provide a theft resistant, non-control operation and reduce vandalism.
- Locks:** Pin tumbler, commercial quality locks keyed like all other AJW cabinets.
- Spindles:** (U005) Fabricated of one-piece molded high impact black ABS material.
- Overall Size:** 6"W x 12"H x 6 3/4"D  
**152mm x 305mm x 171mm**
- Capacity:** Two standard rolls with a 5 1/4" (133mm) OD..

### INSTALLATION

Provide an area on mounting surface at desired or specified location. Open cabinet, remove spindles and hold unit to wall at desired location. Transfer mounting points and drill pilot holes. Secure unit with proper fasteners per each application. Load toilet tissue on rollers, place in concealed track and close hood. Raise lower roll against upper and take hand away. Lower roll should fall into place with upper roll remaining up above the hood line. If loaded properly, top roll will not fall for use until bottom roll has been depleted. When servicing dispenser, full rolls must be used on both spindles to insure proper operation.

All toilet tissue dispensers that meet ADA code cannot have any type of control delivery. (4.16)

### NOTES

Formerly Model #: U840A



# U851 Seat Cover Dispenser

Revision 07/15

JOB #:

ITEM #:

QUANTITY:

MOUNTING	HANDING	TYPE	SIZE	OTHER

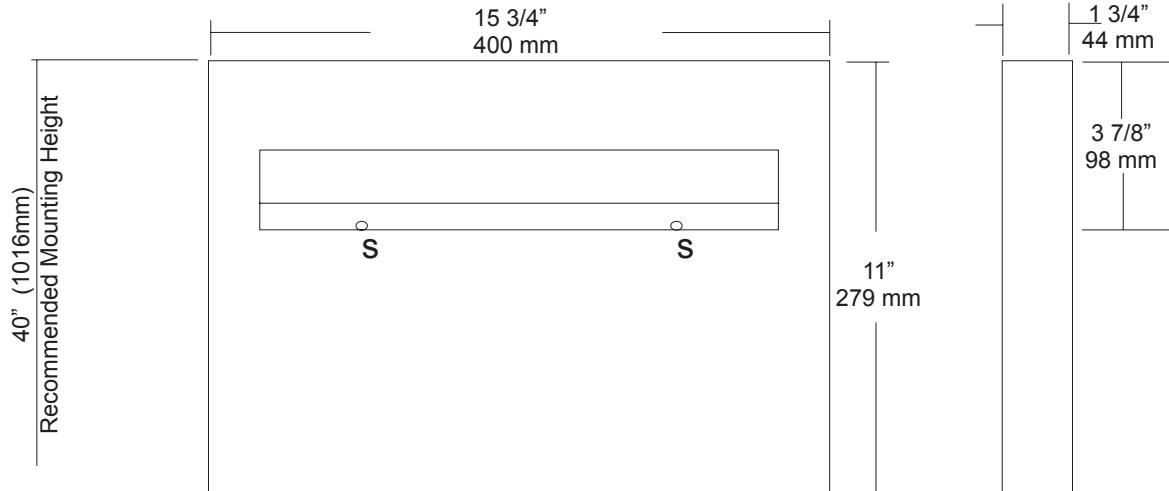

### SPECIFICATIONS

**Dispenser:** Unit is fabricated of #22 gauge stainless steel with a #4 satin finish. Beveled edge around the dispensing areas ensures a clean dispensing area that prevents product from tearing and injury. Loading of product is accomplished from below without having to open any locking mechanism or access panel. Hat style mounting bracket provides added rigidity for body and acts as a support for the packaging.

**Overall Size:** 15 3/4"W x 11"H x 1 3/4"D

**400mm x 279mm x 44mm**

**Capacity:** 500 seat covers

### INSTALLATION

Place unit on wall surface at desired or specified location making sure unit is level. Transfer mounting point locations and drill pilot holes for mounting. Secure unit to surface with proper fasteners per application. Product loads from the bottom out of site from public view.

### NOTES





# U929

## Retractable Shower Seat

Revision 1/14

JOB #:

ITEM #:

QUANTITY:

MOUNTING	HANDING	TYPE	SIZE	OTHER

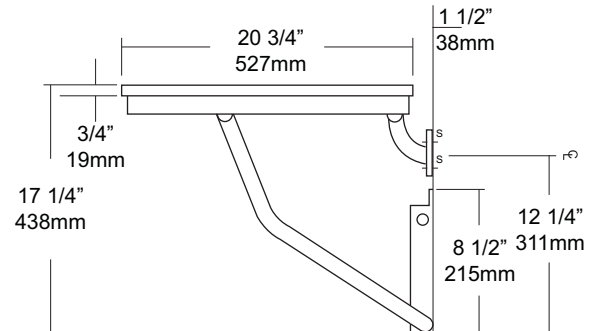
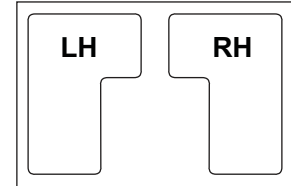
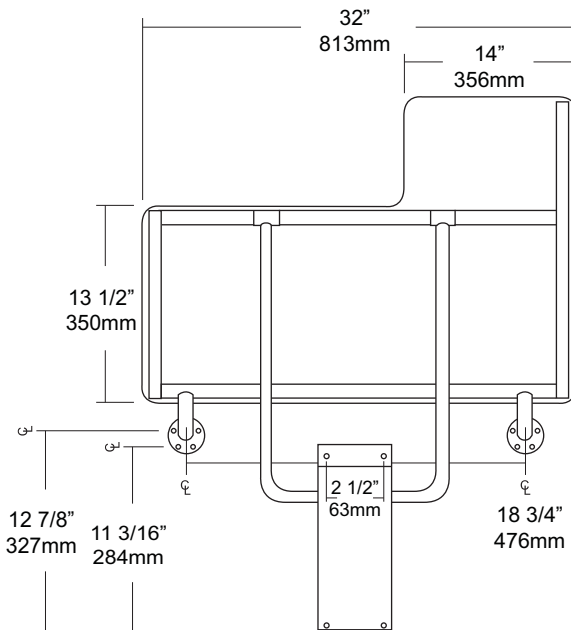

### SPECIFICATIONS

- Seat:** Fabricated of 3/4" thick, one piece polymers (white) with all leading edges having a radius to prevent injury. Seat is secured to frame with carriage bolts and acorn nuts. Seat is reversible and handing is not required
- Tubing:** Fabricated of #18 ga stainless steel with #4 satin finish.
- Main Frame:** 1 1/4" diameter square tubing with capped ends.
- Flanges:** #18 gauge stainless steel with exposed mounting points. Under slung supports have a 1 1/4" OD
- Supports:** #18 ga stainless steel 1 1/4" dia diagonal stainless steel support guides for raising and lowering of seat.
- Mounting Bracket:** #18 gauge stainless steel "hat" style bracket with four (4) mounting points. Bracket acts as a guide for raising and lowering of seat. For maximum support, bracket is mounted resting on floor absorbing load transfer. Seat will remain in an upright position when not in use by means of a spring clip. Seat has been tested to maintain a 500 lb static load.
- Overall Size:** 32"W x 20 3/4"D (seating area)  
813mm x 514mm
- \*Wall to floor mounting design provides equal distribution of weight to ensure safe operation.**

### INSTALLATION

To comply with ADA Code, seat should be mounted at a height between 17" - 19" above finished floor. Check all state and local codes for building requirements.. Recommend in wall mounting on all shower seats. (BP10) Place seat up against wall making sure the extended part of seat has an offset no more than 1 1/2" away from wall. (Same as grab bar) Transfer mounting points to wall surface and drill pilot holes. Secure seat to surface with proper fasteners for each application. Snugly secure seat to surface and check seat to be level. If seat is level raise and lower seat to check path of travel. Finish securing seat after checking seat for proper operation. When properly mounted seat will support up to 500 lbs and will conform with ADA Code 4.21.3 and 4.26.3. To change handing, remove carriage bolts, switch square length tubing to opposite side and flip deck to change handing and secure with carriage bolts to framing.

Note: This shower seat is not intended to be installed in applications that have shower bases with rounded corners. AJW recommends the U928 for such applications.

### NOTES



# UG3-A

Grab Bars

Revised 03/11

JOB #:

ITEM #:

QUANTITY:

MOUNTING	HANDING	TYPE	SIZE	OTHER



## SPECIFICATIONS & INSTALLATION

**Tubing:** Fabricated of #18 ga stainless steel with a #4 satin finish. Available in 1 1/2" outside diameter. All bends are formed by an automatic mandrel bending process. All bars maintain a constant 1 1/2" offset.

**Finish:** Standard finish is a #4 satin finish. For a non-slip finish (peened) add suffix X to model number. (Ex. UG3X-A)

**Flanges:** Snap flanges are fabricated of 3" diameter, 3/8" deep drawn #22 ga stainless steel with #4 satin finish to match tubing. Flanges have dimples that secure over mounting plate.

**Strength:** Bars with a 1 1/2" offset clearance will support loads in excess of 900lbs when properly installed. Bars with greater offsets will support loads up to 250lbs when properly installed.

**Installation:** Before installing grab bars, verify with all state and local codes for requirements on bar diameter and type finish. Recommended mounting heights for grab bars are 33" - 36" centerline above finished floor. All mounting of grab bars when possible should have in wall mounting back plates. Find centerline mounting points and place bar on line making sure to be on center. Transfer mounting points (3 per flange) to wall. Drill pilot holes and secure bar with proper anchors per application. Snap cover over mounting plate.

**Standard Lengths (Other sizes available upon request):** 12", 16", 18", 24", 30", 32", 36", 42", 48", 50", 52", 54", 56"

## FLANGE INFORMATION

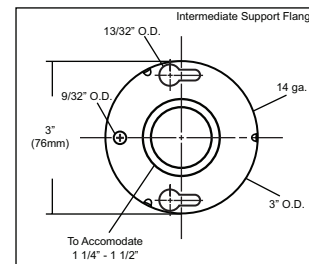
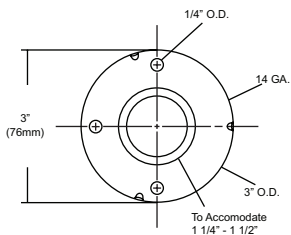
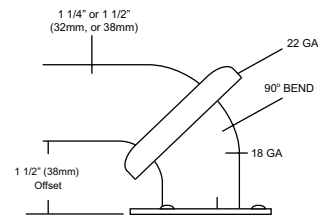

## NOTES



# UG3-G

Grab Bars

Revised 03/11

JOB #:

ITEM #:

QUANTITY:

MOUNTING	HANDING	TYPE	SIZE	OTHER

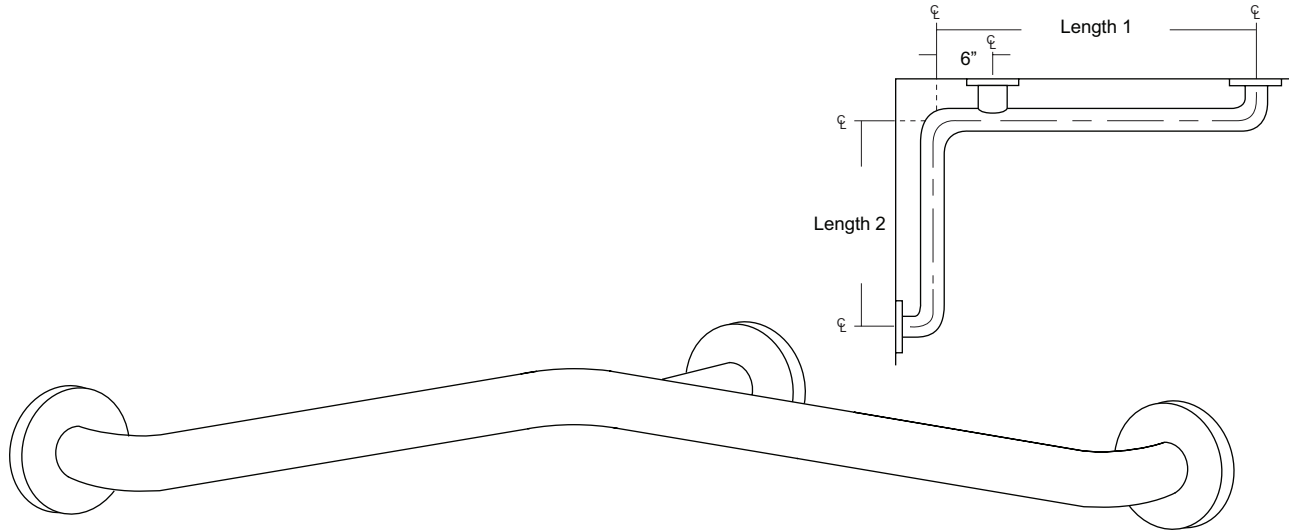

## SPECIFICATIONS & INSTALLATION

**tubing:** Fabricated of #18 ga stainless steel with a #4 satin finish. Available in 1 1/2" outside diameter. All bends are formed by an automatic mandrel bending process. All bars maintain a constant 1 1/2" offset.

**Finish:** Standard finish is a #4 satin finish. For a non-slip finish (peened) add suffix X to model number. (Ex. UG3X-G)

**Flanges:** Snap flanges are fabricated of 3" diameter, 3/8" deep drawn #22 ga stainless steel with #4 satin finish to match tubing. Flanges have dimples that secure over mounting plate.

**Strength:** Bars with a 1 1/2" offset clearance will support loads in excess of 900lbs when properly installed. Bars with greater offsets will support loads up to 250lbs when properly installed.

**Installation:** Before installing grab bars, verify with all state and local codes for requirements on bar diameter and type finish. Recommended mounting heights for grab bars are 33" - 36" centerline above finished floor. All mounting of grab bars when possible should have in wall mounting back plates. Find centerline mounting points and place bar on line making sure to be on center. Transfer mounting points (3 per flange) to wall. Drill pilot holes and secure bar with proper anchors per application. Snap cover over mounting plate.

**Standard Lengths (Other sizes available upon request):** 30" x 16", 30" x 18", 36" x 18", 36" x 24", 42" x 36", 54" x 36"

## FLANGE INFORMATION

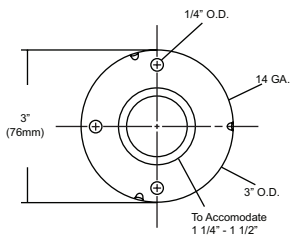
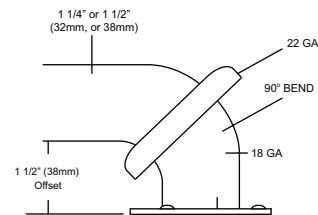

## NOTES



# UJ41 Series

## Mop Holder & Hook Strip Combination Unit

Revision 03/11

JOB #:

ITEM #:

QUANTITY:

MOUNTING	HANDING	TYPE	SIZE	OTHER

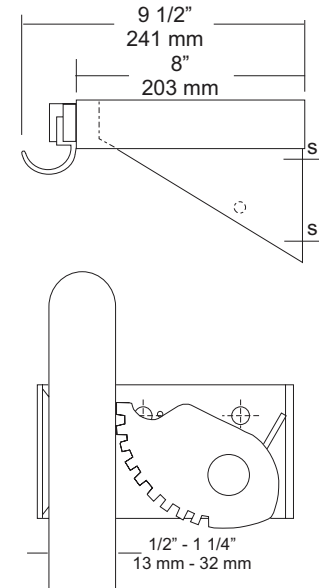
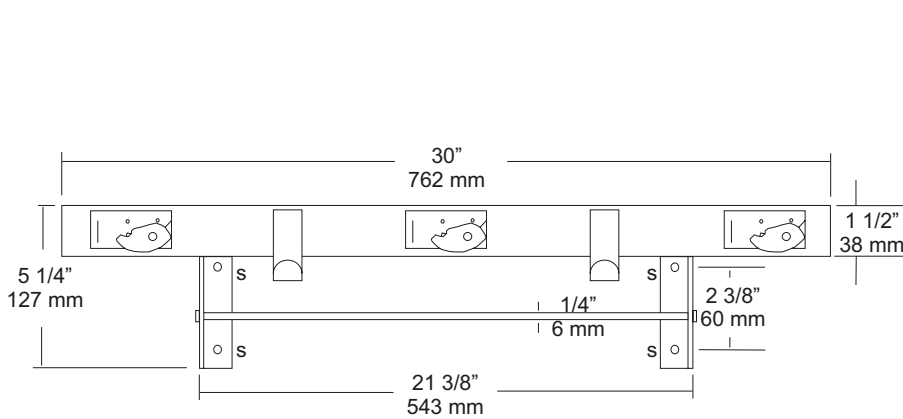

### SPECIFICATIONS

- Shelf:** Fabricated of #18 ga stainless steel with a #4 satin finish, 8" deep (203mm) bent down 1 1/2" with 1/2" returns back for rigidity and safety.
- Mop Holders:** UJ19 plated reinforced steel with serrated cam type hard rubber mop or broom holder. Holds handles 1/2" to 1 1/4" diameter.
- Rag Hooks:** Fabricated of #18 ga stainless steel with a #4 satin finish.
- Mounting Brackets:** #16 ga stainless steel with exposed mounting points.
- Drying Rod:** 1/4" diameter stainless steel rod, secured to outside of support/mounting brackets with locking caps.
- Verify Style:**
- UJ41A:** 30"L (762mm) with 3 holders, 2 hooks.
- Rod Length:** 21 3/8" (565mm)
- UJ41B:** 36"L (914mm) with 4 holders, 3 hooks.
- Rod Length:** 27 3/8" (692mm)
- UJ41C:** 42"L (1066mm) with 5 holders, 4 hooks.
- Rod Length:** 33 3/8" (845mm)
- UJ41D:** 48"L (1219mm) with 6 holders, 5 hooks.
- Rod Length:** 39 3/8" (997mm)

### INSTALLATION

Place unit to wall surface making sure unit is level and transfer mounting points. Drill pilot holes and secure unit with proper fasteners per application.

### NOTES



# UX111-BF

Single Towel Pin

Revision 03/11

JOB #:

ITEM #:

QUANTITY:

MOUNTING	HANDING	TYPE	SIZE	OTHER

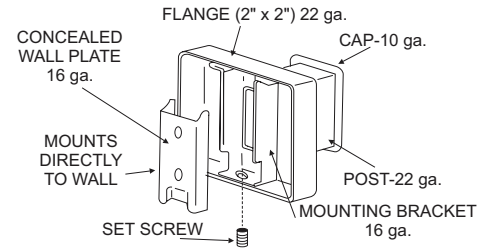
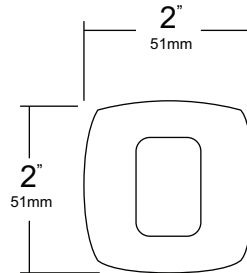
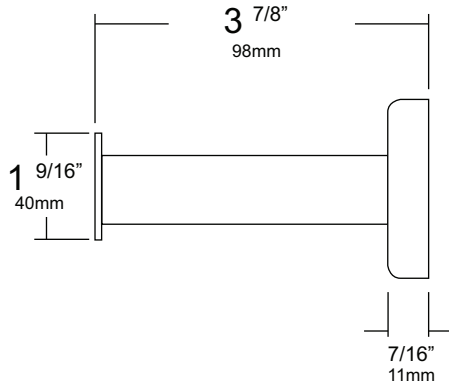

### SPECIFICATIONS

**UX Accessories:** All UX bath accessories series are fabricated of stainless steel with a bright or satin finish. Mounting plates are concealed with a snap-on type plate secured by a set screw.

**Hook:** #10 ga stainless steel hook

**Flange:** 2" x 2" flange #22 ga stainless steel.

**Post:** #22 ga stainless steel.

**Mounting Plate:** #16 ga concealed wall plate. Set screw secures mounting plate and flange.

**Overall Size:** 2"W x 2"H x 3 7/8"

**51mm x 51mm x 120mm**

**UX111-SF:** Same as UX111-BF only satin finish in lieu of a bright finish stainless steel.

### INSTALLATION

Provide an area on wall surface at desired or specified location. Place concealed mounting plate on wall surface and transfer mounting points. Drill pilot holes and secure with proper fasteners. Place snap on flange over plate and secure with set screw.

### NOTES



**UX121-BF**  
Soap Dish

Revision 10/11

JOB #:

ITEM #:

QUANTITY:

MOUNTING	HANDING	TYPE	SIZE	OTHER

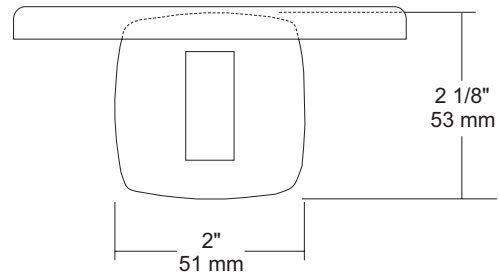
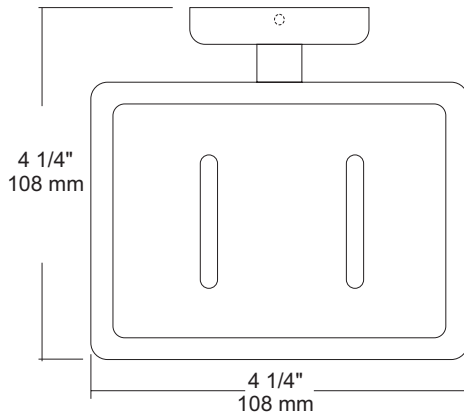

**SPECIFICATIONS**

**UX Accessories:** All UX bath accessories series are fabricated of stainless steel with a bright or satin finish. Mounting plates are concealed with a snap-on type plate secured by a set screw.

**Flange:** 2" x 2" flange #22 ga stainless steel.

**Post:** #22 ga stainless steel.

**Mounting Plate:** #16 ga concealed wall plate. Set screw secures mounting plate and flange.

**Soap Dish:** #22 ga stainless steel without drain holes

**Overall Size:** 4 1/4"W x 2 1/8"H x 4 1/4"D

**108mm x 54mm x 108mm**

**UX121-SF:** Same as UX121-BF with satin finish.

**INSTALLATION**

Provide an area on wall surface at desired or specified location. Place concealed mounting plate on wall surface and transfer mounting points. Drill pilot holes and secure with proper fasteners. Place snap on flange over plate and secure with set screw.

**NOTES**

JOB #:

ITEM #:

QUANTITY:

MOUNTING	HANDING	TYPE	SIZE	OTHER

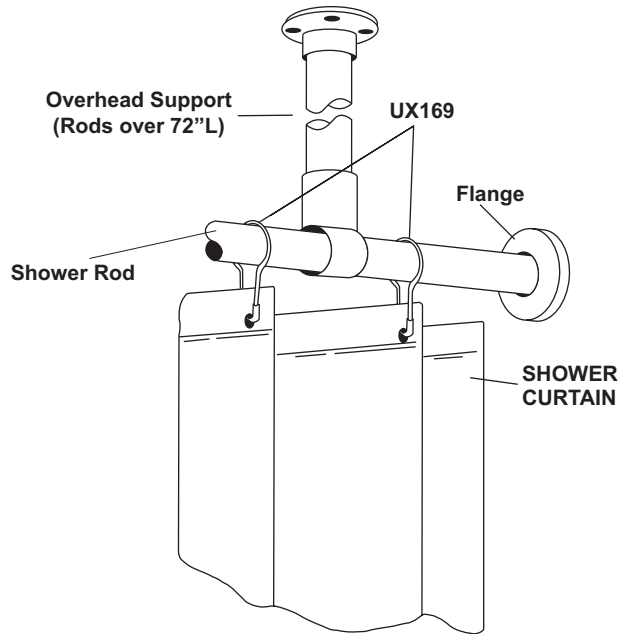

SPECIFICATIONS	INSTALLATION
----------------	--------------

**Bacteria & Mildew Resistant:** Heavy duty vinyl film (8 mil) that is flame retardant, durable and waterproof. Microbiotic KV-33 is an integral part added to the fabrication of this curtain that can be laundered repeatedly without losing this barrier against bacteria, fungus and mildew. KV-33 is a durable bacteriostat, mildewstat and fungistat that will provide protection for as long as you use this style curtain. It will retard the growth of organisms, thereby inhibiting odors caused by decaying bacteria.

**Design:** To insure the ultimate in bacteria free curtain, there are no side hems to hinder the flow-off of soap and water. This also makes cleaning easier. The heading is reinforced with a ten gauge vinyl film with rust proof anodized eyelets spaced 6" apart.

**Cleaning:** Sponge with warm mild soap and rinse with clear water.

**Machine washing:** Relatively cool water temp not to exceed 120 degrees F. DO NOT USE DETERGENTS. Air dry at low temp. Colors: Standard stock color is white. Special order for other colors are available on request.

\*UX1-V/UX2-V: Overhead s/s supports for oversized shower rods. (For shower rods over 72" in length an overhead support is recommended)

**UX1-V:** 1" OD shower rods.

**UX2-V:** 1 1/4" OD shower rods.

Recommended: UX169 stainless steel shower curtain hooks to connect to AJW shower curtain rods. Various types of flanges are available to secure rod and curtain to mounting surface (exposed and concealed).

Measuring Curtains: Curtains are measured W x H. The same curtain will fit a 1 or 1 1/4" diameter rod.

**NOTES**

Formerly Model #: 250P



**UX2K**  
Flange & Shower Rod

Revision 03/11

JOB #:

ITEM #:

QUANTITY:

MOUNTING	HANDING	TYPE	SIZE	OTHER

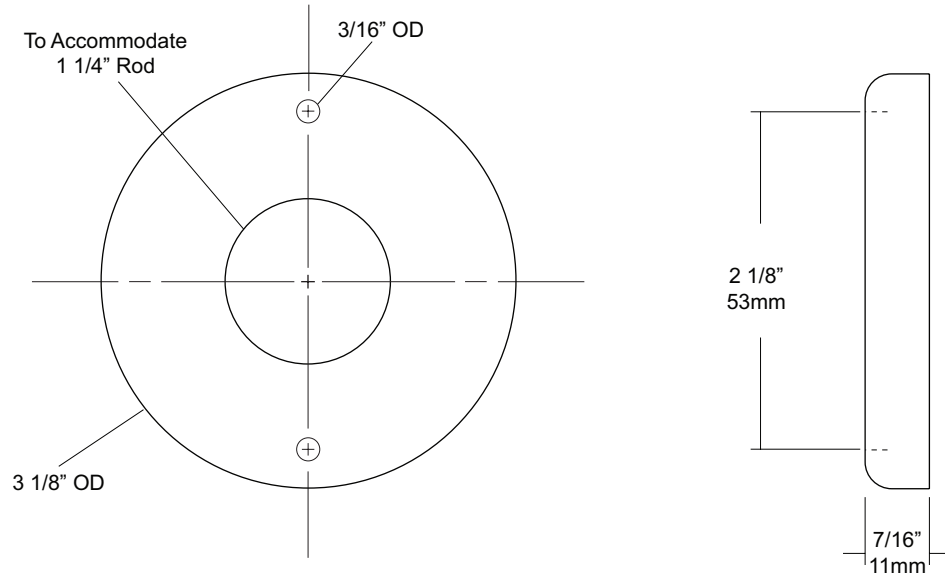

**SPECIFICATIONS**

**Exposed Cover:** Fabricated of #22 gauge stainless steel with a #4 satin finish. Cover has two (2) exposed mounting points.

**Shower Rod:** Fabricated of stainless steel with a #4 satin finish.

**UX2:** 1 1/4" outside diameter

**INSTALLATION**

Provide an area on wall surface at desired or specified location. Hold flange to wall surface and transfer mounting points. Drill pilot holes. Place flanges on the ends of the rods. Secure flanges to wall surface with proper fasteners per application.

**NOTES**