

date	1
projectname	1
attn	1
from	
fax	
email	
phone	



U7018B Series
Stainless Steel Frameless Mirror

Revision 06/11

JOB #:

ITEM #:

QUANTITY:

MOUNTING	HANDING	TYPE	SIZE	OTHER

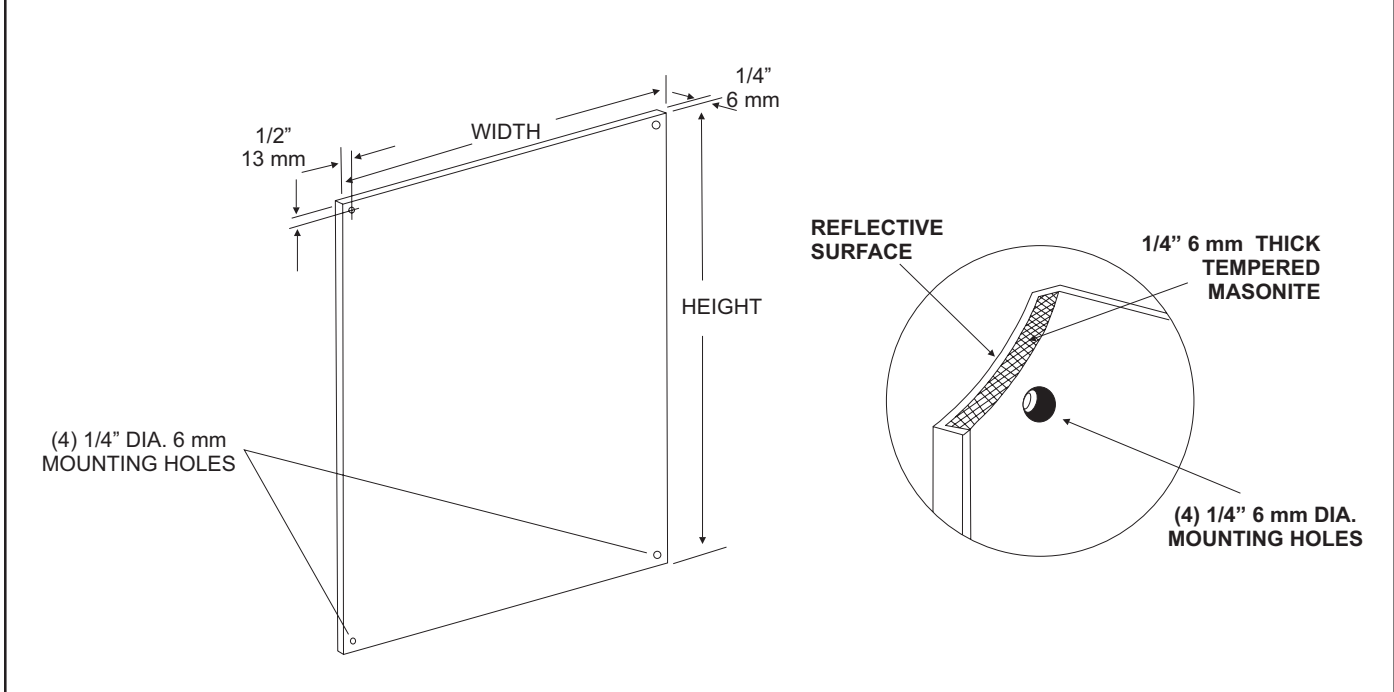

SPECIFICATIONS

Mirror: Type 304 #20 ga stainless steel with #8B architectural finish. Both mirrors have 1/4" returns to wall surface for rigidity surrounding 1/4" thick tempered masonite backing. 1/4" diameter exposed mounting points are provided. Each mirror is shipped with a removable vinyl protective coating.

Note: Stainless steel mirrors reflect images in different optic quality than plate glass. There will be a slight distortion which increases proportionately with the mirror size. Therefore we cannot be held responsible for quality of image.

Cleaning: Non-abrasive and non-chloric solutions should be used to clean stainless steel mirrors.

These Mirrors are always ordered Width x Height

INSTALLATION

Provide an area at desired or specified location and strike a line that is level. Place mirror at this line and check again with level. Transfer mounting locations to wall surface and drill pilot holes. Peel off vinyl coating around corners only before securing to wall. Secure mirror with proper fasteners per each application. Do not over tighten fasteners. If a depression is formed by over-tightening the reflective quality may be affected. Remove remainder of vinyl coating after mirror checks with level and is properly secured. The bottom reflective surface edge must be mounted 40" above finished floor to comply with ADA code, 4.19.6.

NOTES

MOUNTING	HANDING	TYPE	SIZE	OTHER
----------	---------	------	------	-------

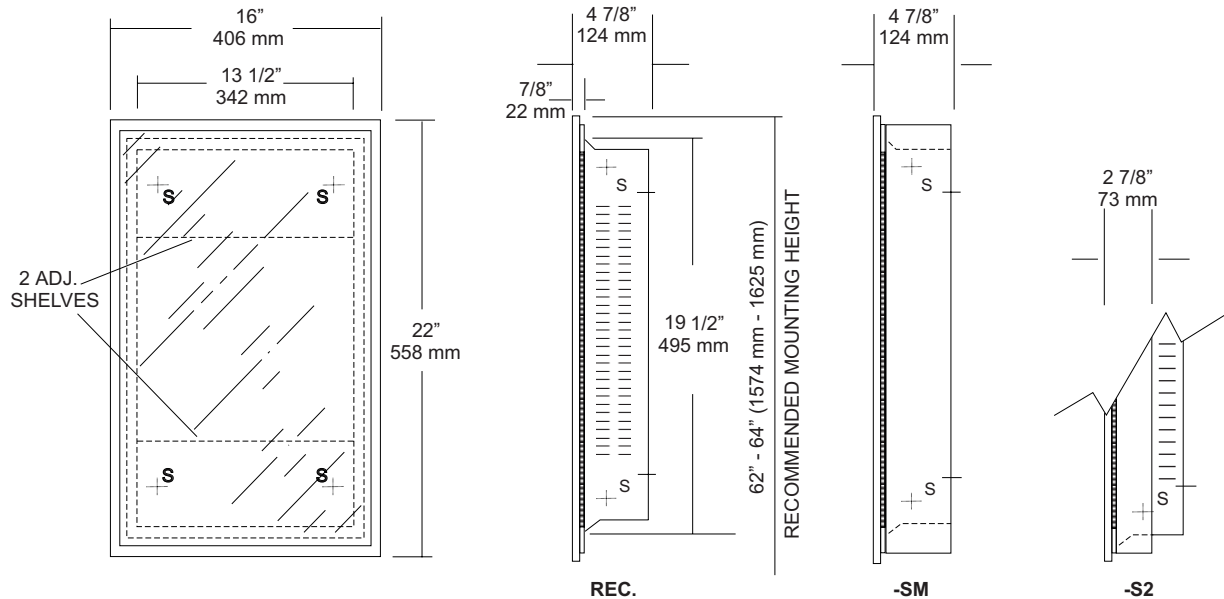

SPECIFICATIONS

Cabinet Body: Fabricated of #22 ga stainless steel formed for rigidity. Embossed louvers in body allow shelving to be adjustable. Flange surrounds cabinet body that has 1/4" returns to wall. (No miters or welds)

Cabinet Back: Stainless steel secured to cabinet body with multiple welds to cabinet body.

Mirror Door: 1/4" thick float plate glass, silver coated and sealed with a uniform coating of electrolytic copper plating. Mirror is guaranteed against silver spoilage for a period of 15 years. Non-absorbent filler behind mirror acts as a shock absorber.

Channel Frame: #22 ga stainless steel #4 satin finish.

Adjustable Shelving: Two (2) #22 ga stainless steel with #4 satin

Catch: Heavy duty magnetic catch.

Hinges: Full length, heavy duty stainless steel piano type

Collars: #22 ga stainless steel with #4 satin, one piece construction, finished to match cabinet body.

Overall Size: 16"W x 22"H x 4 7/8"D
406mm x 558mm x 124mm

Wall Opening: 14"W x 20"H x 4"D
355mm x 508mm x 102mm

U720-1622-S2: 2" Semi-Recessing collar, 2" wall opening

U720-1622-SM: Fully surface mounted collar

INSTALLATION

Coordinate installation with architect and contractor. Provide a wall opening 14"W x 20"H. Depth will depend on style mounting. Insert cabinet into opening making sure cabinet is level and door will remain open until you manually close it. Secure cabinet with proper fasteners per application. Unit can be mounted to have a right hand or left hand swing door. Collars can be added in the field to accommodate semi-recessing or full surface mounting.

To comply with ADA code, one usable shelf must be mounted no higher than 44" above finished floor. (4.2.4)

NOTES

Formerly Model #: U721-1622



U811
Toilet Tissue Dispenser

Revision 03/11

JOB #:

ITEM #:

QUANTITY:

MOUNTING	HANDING	TYPE	SIZE	OTHER

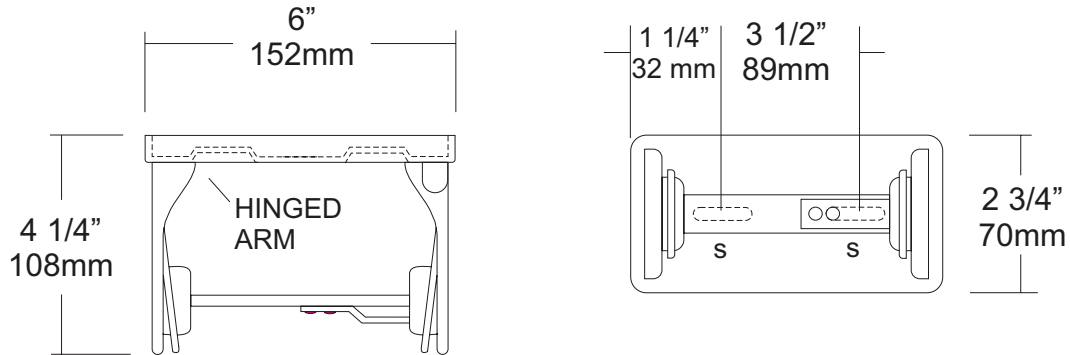

SPECIFICATIONS

Mounting Plate: Bright chrome plated #22 ga steel formed for maximum strength.
Arms: Hinged arms (one for each roll) are #22 ga bright chrome plated. The other arm is fixed. Both arms are fabricated with an extended support to maintain toilet tissue roll. This is a controlled type dispensing system.
Overall Size: 6"W x 2 3/4"H x 4 1/4"D
152mm x 70mm x 108mm
Capacity: One standard roll with a 5 1/4" (133mm) OD.

INSTALLATION

Provide an area on wall surface at desired or specified location. Hold unit to surface and make sure unit is level. Transfer mounting points to wall and drill pilot holes. Secure units with proper fasteners per application. Open units by depressing tab on spindle that allows arm to unlock. Load tissue on spindle and snap close.
 Toilet Paper Dispensers: All dispensers that are to meet ADA code cannot have any type of controlled delivery. (4.16)

NOTES

UB32 Series Heavy Duty Towel Bar

Revision 03/11

JOB #:

ITEM #:

QUANTITY:

MOUNTING	HANDING	TYPE	SIZE	OTHER

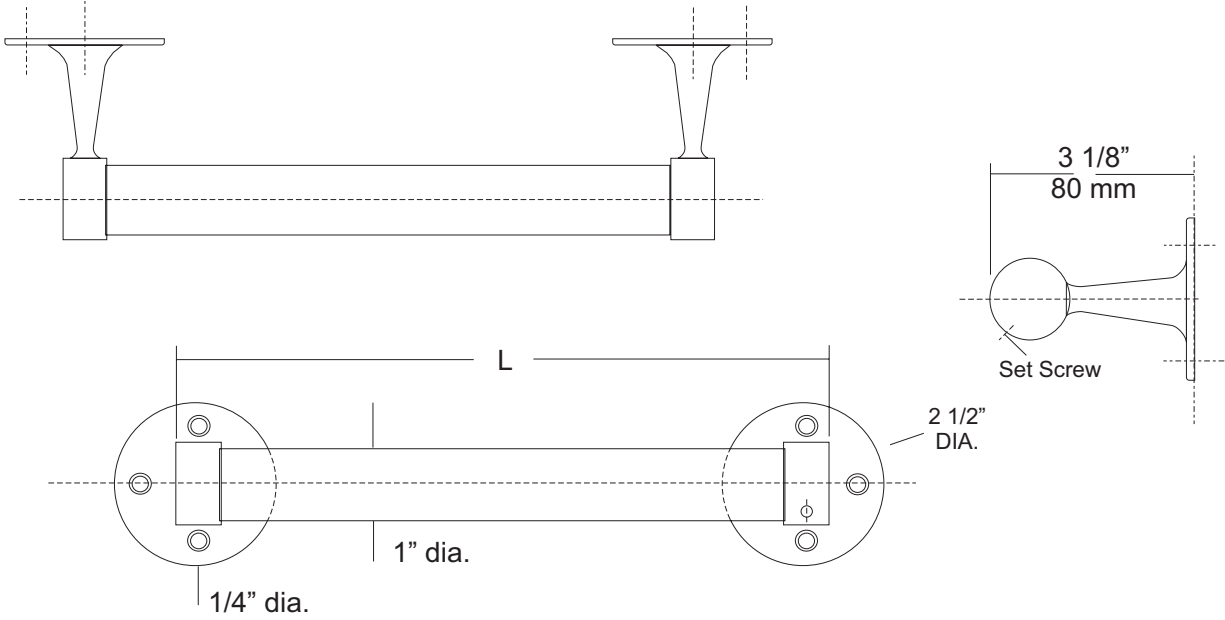

SPECIFICATIONS

Posts: Fabricated of solid forged brass finished with a chrome plated bright finish. Mounting flange is equipped with three countersunk mounting points. (1/4" Dia.). One post is equipped with a set screw to prevent bar from rotating.

Bar: Fabricated of #18 ga stainless steel with a bright finish. Diameter of bar is 1" (26mm)

Standard Lengths: 18", 24", 30", 36"

UB32-SF: Same as UB32 with satin finish

INSTALLATION

Place towel bar inside the post ends and hold up to mounting surface. Making sure unit is level, transfer mounting points from each flange and drill pilot holes. Secure one to mounting surface with proper fasteners per application. Insert bar into mounted post and slide other post over bar. Holding post against wall, secure flange to wall.

NOTES

Formerly Model #: UBK6000 Series

JOB #:

ITEM #:

QUANTITY:

MOUNTING	HANDING	TYPE	SIZE	OTHER

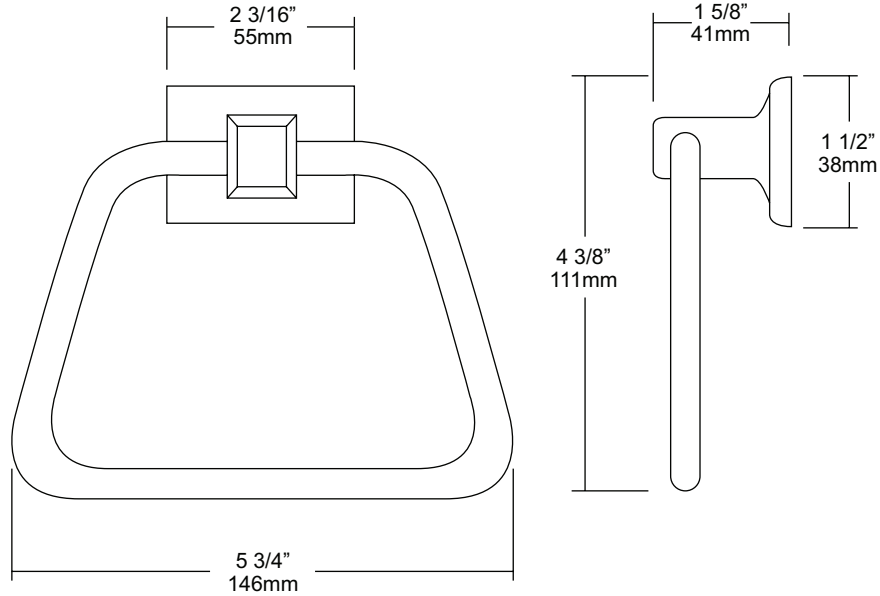

SPECIFICATIONS

UC Accessories: All accessories are fabricated of high polished chrome plating over virgin zinc die cast. All UC items comply with standard federal specifications.

Overall Size: 5 3/4"W x 4 3/8"H x 1 5/8"D

146mm x 110mm x 43mm

INSTALLATION

Place concealed mounting bracket on wall surface at desired location. Transfer mounting points and drill pilot holes. Secure plate with proper fasteners per application. Place item over plate making sure it fits snugly and secure on the underside with supplied set screw.

NOTES



UC41

Toilet Tissue Dispenser

Revision 03/11

JOB #:

ITEM #:

QUANTITY:

MOUNTING	HANDING	TYPE	SIZE	OTHER

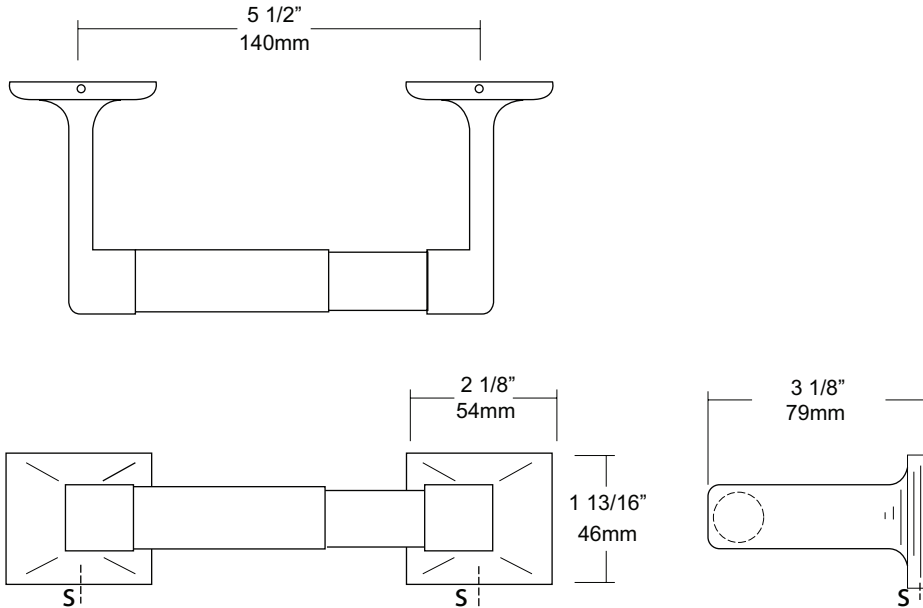

SPECIFICATIONS

UC Accessories: All accessories are fabricated of high polished chrome plating over virgin zinc die cast. All UC items comply with standard federal specifications.

Rollers: White ABS rollers with heavy duty internal spring. Optional chrome plated roller available on request.

Optional U007 Theft Resistant Adapter: Prevents spindle from being removed until roll has been depleted.

Overall Size: 7 5/8"W x 1 13/16"H x 3 1/8"D (without roll)

195mm x 44mm x 79mm

Capacity: One standard roll with a 5 1/4" (133mm) OD

INSTALLATION

Place concealed mounting bracket on wall surface at desired location. Transfer mounting points and drill pilot holes. Secure plate with proper fasteners per application. Place item over plate making sure it fits snugly and secure on the underside with supplied set screw. Do this three times maintaining a 5 1/2" space centerline between posts. Make sure the post you select to be mounted as center post will accommodate two rolls and not the end post.

Toilet Paper Dispensers: All dispensers that are to meet ADA code cannot have any type of controlled delivery. (4.16)

NOTES



UG3-A

Grab Bars

Revised 03/11

JOB #:

ITEM #:

QUANTITY:

MOUNTING	HANDING	TYPE	SIZE	OTHER

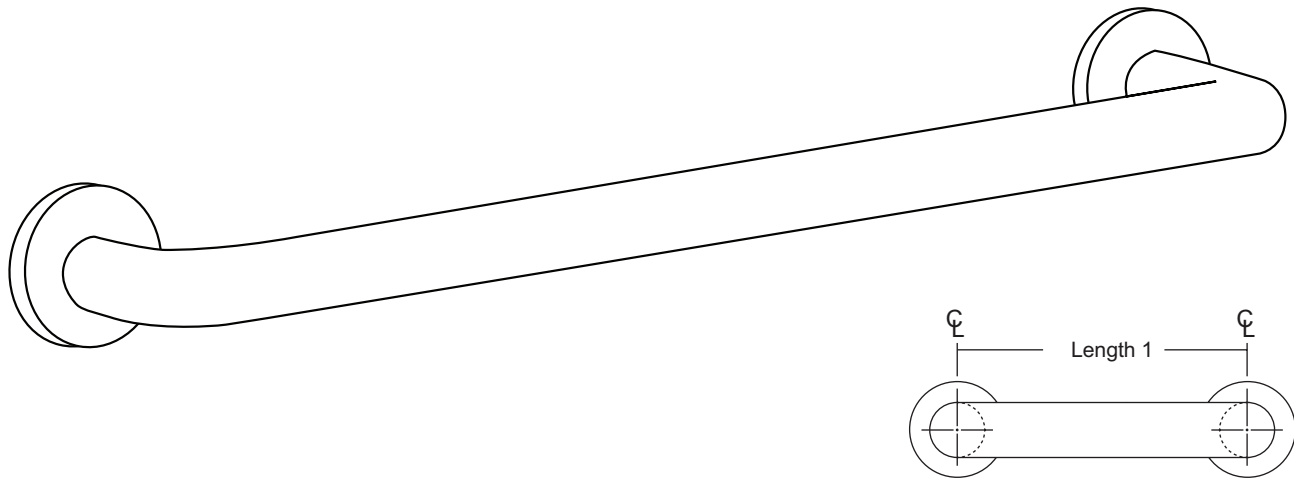

SPECIFICATIONS & INSTALLATION

Tubing: Fabricated of #18 ga stainless steel with a #4 satin finish. Available in 1 1/2" outside diameter. All bends are formed by an automatic mandrel bending process. All bars maintain a constant 1 1/2" offset.

Finish: Standard finish is a #4 satin finish. For a non-slip finish (peened) add suffix X to model number. (Ex. UG3X-A)

Flanges: Snap flanges are fabricated of 3" diameter, 3/8" deep drawn #22 ga stainless steel with #4 satin finish to match tubing. Flanges have dimples that secure over mounting plate.

Strength: Bars with a 1 1/2" offset clearance will support loads in excess of 900lbs when properly installed. Bars with greater offsets will support loads up to 250lbs when properly installed.

Installation: Before installing grab bars, verify with all state and local codes for requirements on bar diameter and type finish. Recommended mounting heights for grab bars are 33" - 36" centerline above finished floor. All mounting of grab bars when possible should have in wall mounting back plates. Find centerline mounting points and place bar on line making sure to be on center. Transfer mounting points (3 per flange) to wall. Drill pilot holes and secure bar with proper anchors per application. Snap cover over mounting plate.

Standard Lengths (Other sizes available upon request): 12", 16", 18", 24", 30", 32", 36", 42", 48", 50", 52", 54", 56"

FLANGE INFORMATION

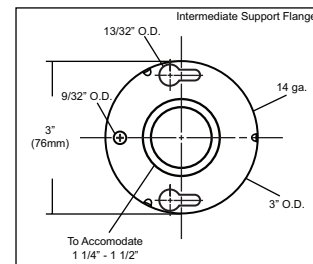
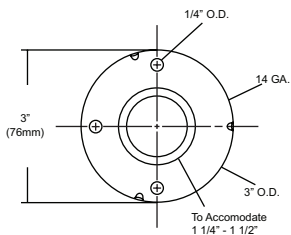
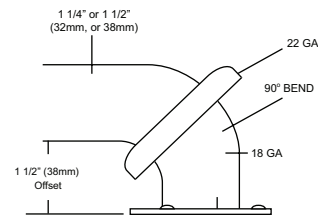

NOTES



UX2K
Flange & Shower Rod

Revision 03/11

JOB #:

ITEM #:

QUANTITY:

MOUNTING	HANDING	TYPE	SIZE	OTHER

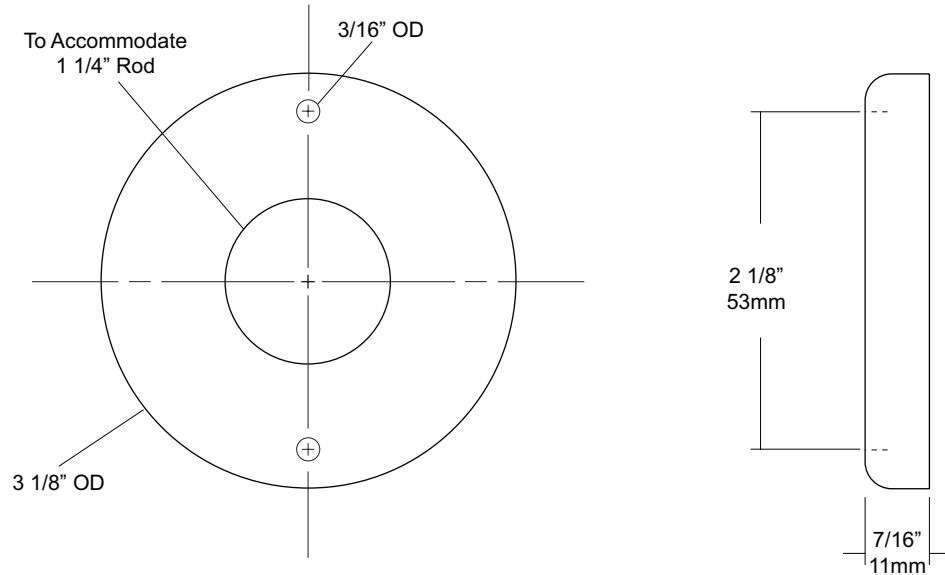

SPECIFICATIONS

Exposed Cover: Fabricated of #22 gauge stainless steel with a #4 satin finish. Cover has two (2) exposed mounting points.

Shower Rod: Fabricated of stainless steel with a #4 satin finish.

UX2: 1 1/4" outside diameter

INSTALLATION

Provide an area on wall surface at desired or specified location. Hold flange to wall surface and transfer mounting points. Drill pilot holes. Place flanges on the ends of the rods. Secure flanges to wall surface with proper fasteners per application.

NOTES