

date
projectname
attn
from
fax
email
phone

3/8/17
Wilton Fire
Brian
Brian



U199CP

Center-Pull Towel Dispenser

Revision 03/11

JOB #:

ITEM #:

QUANTITY:

MOUNTING	HANDING	TYPE	SIZE	OTHER

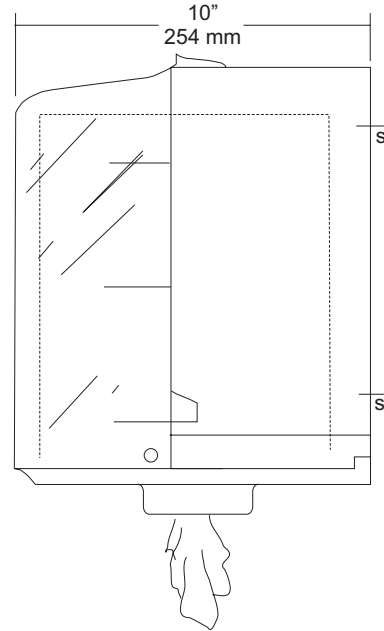
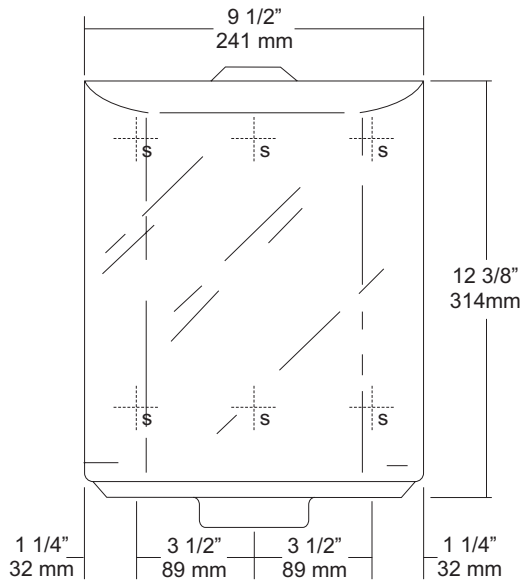

SPECIFICATIONS

Cabinet Body: Fabricated of high impact ABS material.
Cover: Translucent ABS material that is corrosion resistant with a rounded design.
Lock: Cover is secured to body by means of a special key.
Dispensing area: Towels are dispensed from bottom without any serrated edges that may cause injury. An adjustable site controls the opening where the paper will be dispensed.
Overall Size: 9 1/2"x 12 3/8"H x 10"D
241mm x 314mm x 254mm
Capacity: One standard center pull roll. For best operation a perforated roll is recommended.

INSTALLATION

Provide an area at specified or desired location. Open cabinet and hold unit on wall surface. Making sure unit is level transfer mounting point locations to wall surface and drill pilot holes. Secure cabinet with proper fasteners per application. Load paper towels and feed through rollers per instructions on label inside cabinet. Close cabinet and test cabinet for proper towel length and dispensing operation. Controls should be operable with one hand and force required to operate must be less than 5 lbs. (4.27.4)

NOTES



U590
 Sanitary Napkin Disposal with Access Panel
 Revision 10/11

JOB #:
 ITEM #:
 QUANTITY:

MOUNTING	HANDING	TYPE	SIZE	OTHER

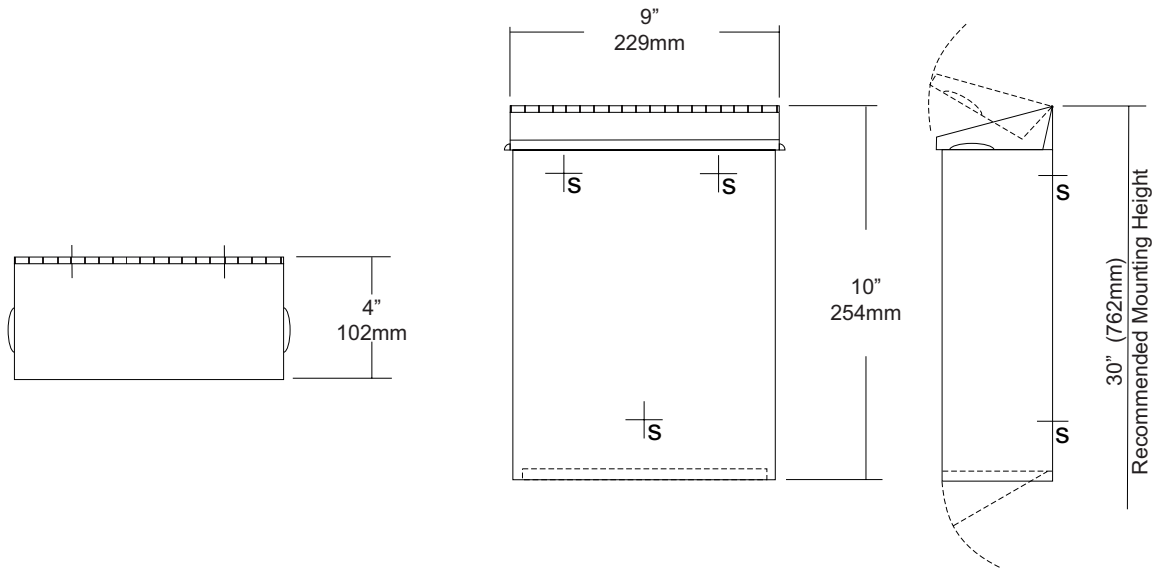

SPECIFICATIONS	INSTALLATION
----------------	--------------

Cabinet Body: Fabricated of #22 ga stainless steel with #4 satin finish. Seamless construction with radius and hemmed edges.

Cabinet Back: Fabricated of Stainless steel welded to cabinet body with key hole mounting points.

Cover: Fabricated of #22 ga stainless steel #4 satin finish with embossed handles on each side and sloped top.

Bottom Panel: #22 ga hinged and locked for removal of contents.

Hinges: Heavy duty, full length, stainless steel piano type hinges.

Lock: Commercial quality keyed like all other AJW cabinets.

Overall Size: 9"W x 10"H x 4"D
229mm x 254mm x 102mm

Capacity: 1.6 gallons (.2 cu ft)

NDL-13-50: Waxed disposable liners. (50 per Case)

Provide an area at desired or specified location. Place unit on surface and transfer mounting points. Drill pilot holes and secure with proper fasteners. Install waxed liner.

NOTES