

date  
projectname  
attn  
from  
fax  
email  
phone

A  
A  
AAAAAA

JOB #:

ITEM #:

QUANTITY:

MOUNTING	HANDING	TYPE	SIZE	OTHER

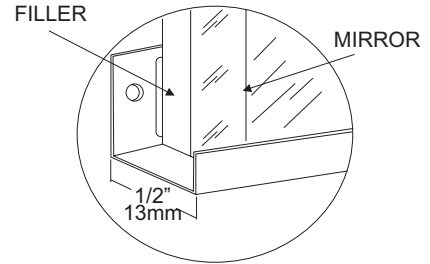
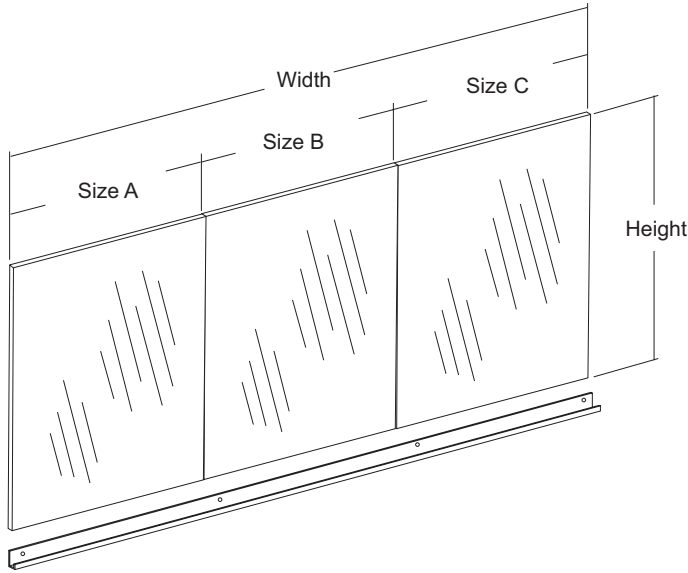

### SPECIFICATIONS

**Mirror:** 1/4" thick type 1 transparent flat type, class 1 - clear glass mirrors. Mirror is coated with silver and sealed with a uniform electrolytic copper plating, along with two coats of paint for added protection. Mirrors are guaranteed against silver spoilage for a period of 15 years. Mirrors conform to ASTM C1036 and ASTM C1503-R8.

**Frame:** #18 ga stainless steel with a #4 satin finish. (1/2" x 1/2" x 1 3/4" channel)

**Backing:** 1/4" thick tempered Masonite backing strips.

**Optional Surfaces & Sizes:**

- PM: Plastic Mirrors (96" x 48" max size for 1 piece of glass)
- PG: Plate Glass (Floor) (96" x 48" max size for 1 piece of glass)
- LG: Laminated Glass (96" x 48" max size for 1 piece of glass)
- T: Tempered Mirror (96" x 48" max size for 1 piece of glass)
- VC: Vinyl Clad (96" x 48" for 1 piece of glass)

**When mirrors are fabricated with multiple pieces of glass, size of each piece must be specified.**

**Mirrors are always ordered Width x Height**

**Fabricated to a tolerance of ± 1/8"**

### INSTALLATION

Mount the bottom channel at desired or specified location. Place a level across the channel to make sure mirror will be level. Place glass and Masonite strips (vertical) in channel and check with level again. Clips are required on the top for securing mirror properly. (SCL-J: stainless steel clips)

### NOTES

JOB #:

ITEM #:

QUANTITY:

MOUNTING	HANDING	TYPE	SIZE	OTHER

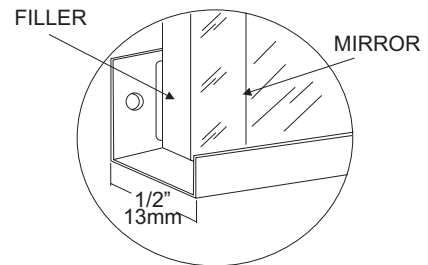
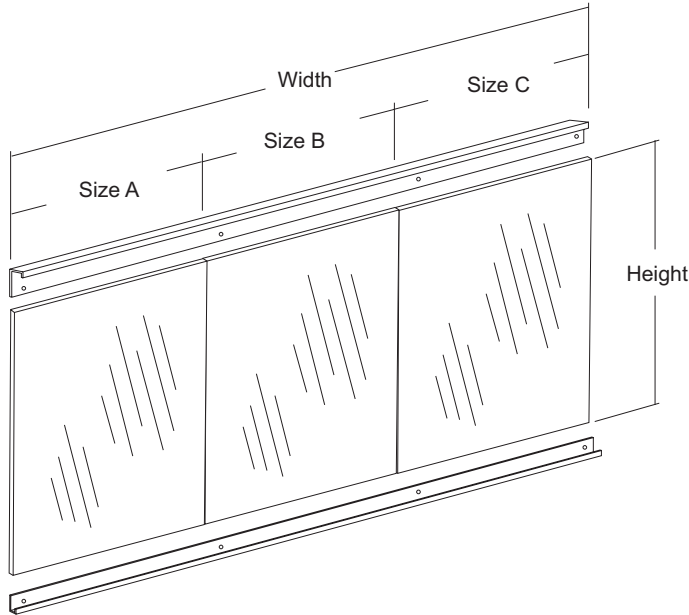

### SPECIFICATIONS

**Mirror:** 1/4" thick type 1 transparent flat type, class 1 - clear glass mirrors. Mirror is coated with silver and sealed with a uniform electrolytic copper plating, along with two coats of paint for added protection. Mirrors are guaranteed against silver spoilage for a period of 15 years. Mirrors conform to ASTM C1036 and ASTM C1503-R8.

**Frame:** #18 ga stainless steel with a #4 satin finish. (1/2" x 1/2" x 1 3/4" channel)

**Backing:** 1/4" thick tempered Masonite backing strips.

**Optional Surfaces & Sizes:**

- PM: Plastic Mirrors (96" x 48" max size for 1 piece of glass)
- PG: Plate Glass (Floor) (96" x 48" max size for 1 piece of glass)
- LG: Laminated Glass (96" x 48" max size for 1 piece of glass)
- T: Tempered Mirror (96" x 48" max size for 1 piece of glass)
- VC: Vinyl Clad (96" x 48" for 1 piece of glass)

**When mirrors are fabricated with multiple pieces of glass, size of each piece must be specified.**

**Mirrors are always ordered Width x Height**

**Fabricated to a tolerance of ± 1/8"**

### INSTALLATION

Mount the bottom channel at desired or specified location. Place a level across the channel to make sure mirror will be level. Place glass and Masonite strips (vertical) in channel and check with level again. Clips are required on the top for securing mirror properly. (SCL-J: stainless steel clips). Measure from the bottom "J" mold up height of mirror and strike a line. Mount top "J" the same way allowing 3/4" to lock glass in place. Place glass and Masonite in channel and slide top "J" down to lock in place.

The bottom reflective surface edge must be mounted 40" above finished floor to comply with ADA code, 4.19.6.

### NOTES

JOB #:

ITEM #:

QUANTITY:

MOUNTING	HANDING	TYPE	SIZE	OTHER

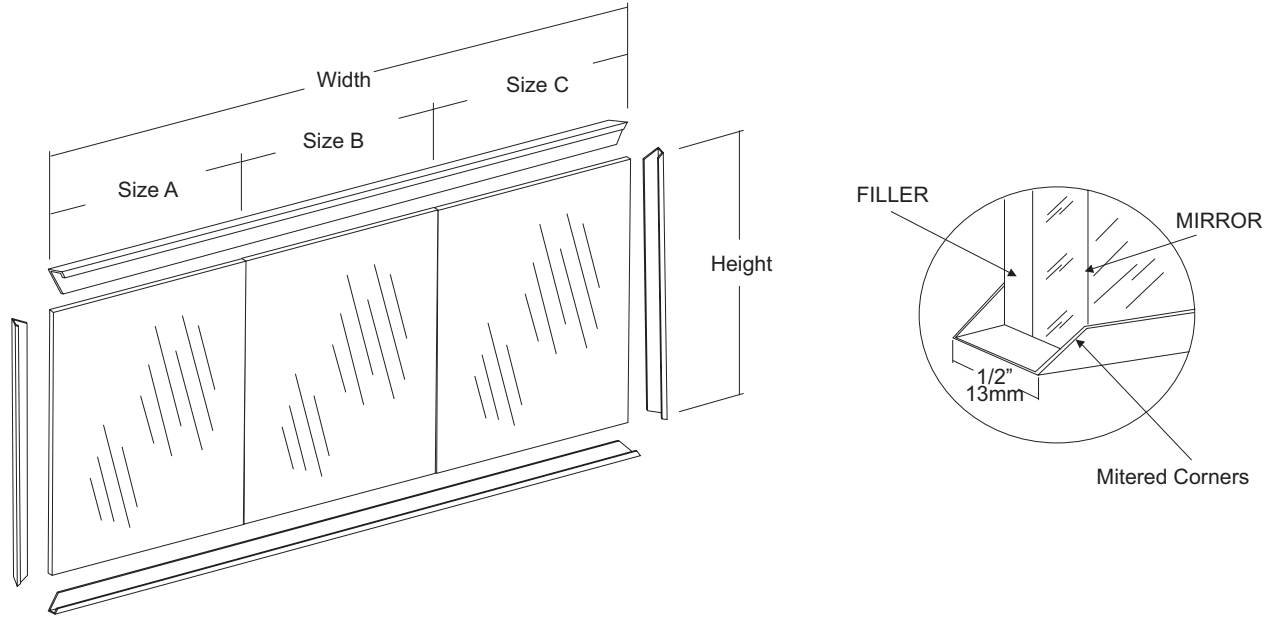

### SPECIFICATIONS

**Mirror:** 1/4" thick type 1 transparent flat type, class 1 - clear glass mirrors. Mirror is coated with silver and sealed with a uniform electrolytic copper plating, along with two coats of paint for added protection. Mirrors are guaranteed against silver spoilage for a period of 15 years. Mirrors conform to ASTM C1036 and ASTM C1503-R8.

**Frame:** #18 ga stainless steel with a #4 satin finish. (1/2" x 1/2" x 1 3/4" channel)

**Backing:** 1/4" thick tempered Masonite backing strips.

**Optional Surfaces & Sizes:**

- PM: Plastic Mirrors (96" x 48" max size for 1 piece of glass)
- PG: Plate Glass (Floor) (96" x 48" max size for 1 piece of glass)
- LG: Laminated Glass (96" x 48" max size for 1 piece of glass)
- T: Tempered Mirror (96" x 48" max size for 1 piece of glass)
- VC: Vinyl Clad (96" x 48" for 1 piece of glass)

**When mirrors are fabricated with multiple pieces of glass, size of each piece must be specified.**

**Mirrors are always ordered Width x Height**

**Fabricated to a tolerance of ± 1/8"**

### INSTALLATION

Mount the bottom channel at desired or specified location. Place a level across the channel to make sure mirror will be level. Place glass and Masonite strips (vertical) in channel and check with level again. Clips are required on the top for securing mirror properly. (SCL-J: stainless steel clips). Measure from the bottom "J" mold up height of mirror and strike a line. Mount top "J" the same way allowing 3/4" to lock glass in place. Place glass and Masonite in channel and slide top "J" down to lock in place. Follow the same instructions for top and bottom style and add the two side "J" channel.

The bottom reflective surface edge must be mounted 40" above finished floor to comply with ADA code, 4.19.6.

### NOTES