

date  
projectname  
attn  
from  
fax  
email  
phone

08-23-21  
Pell elem  
Fred



# U410

## Semi-Recessed Waste Receptacle

Revision 03/11

JOB #:
ITEM #:
QUANTITY:

MOUNTING	HANDING	TYPE	SIZE	OTHER

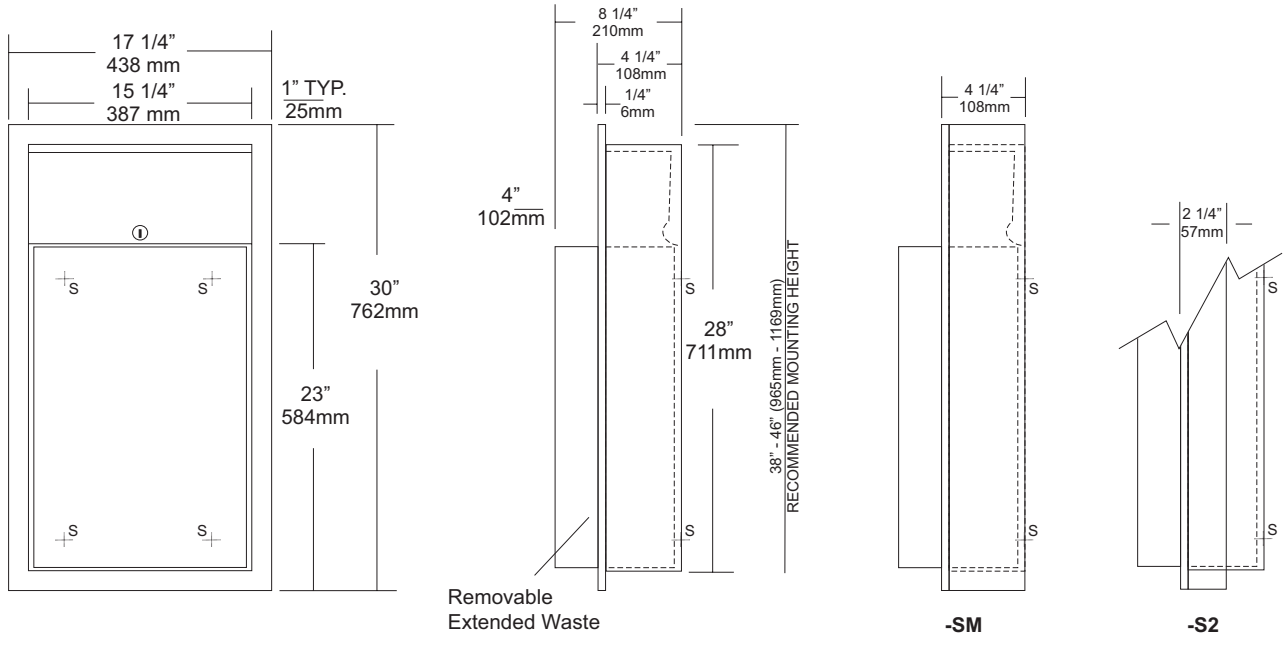

SPECIFICATIONS	INSTALLATION
----------------	--------------

**Body:** Fabricated of #22 ga stainless steel with #4 satin finish on all exposed areas.

**Flange:** Fabricated of #22 ga stainless steel finished to match cabinet. One piece construction without miters or welds with 1/4" returns to wall surface for maximum strength.

**Back:** Fabricated of stainless steel formed for rigidity with multiple welds to cabinet body to form a one-piece construction.

**Removable Waste:** #22 ga stainless steel with #4 satin finish with hemmed edges and radius corners. Hook tabs allow liner to be installed are an integral part of waste can. Waste is secured in place by tumbler lock and bottom hanger. (12 gallon capacity)

**Lock:** Pin tumbler, commercial quality, keyed like all other AJW cabinets.

**Collars:** #22 ga stainless steel, sized & finished to match cabinet. (Used for surface mounting & semi-recessing)

**Overall Size:** 17 1/4"W x 30"H x 8 1/4"D (4" extended waste)  
**438mm x 762mm x 203mm**

**Wall Opening:** 15 3/4"W x 28 1/2"H x 4"D  
**400mm x 724mm x 102mm**

**U410-S2:** semi-recessed 2" collar(2" wall open.,51mm)

**U410-SM:** Surface mounting collar

**Waste Capacity:** 12 gallons (1.6 cu ft)

**Options:**

- VL1: Reusable vinyl liner
- CV: Covered Waste

Coordinate installation with architect and contractor. Provide a wall opening 15 3/4"W x 28 1/2"H . Wall depth will vary if collars are required. Remove waste from cabinet and insert into opening. Secure unit with proper fasteners for each application. Make sure each unit is plumb and true. Secure unit in cabinet by locking in place by tumbler lock. Liners may be installed. (VL1 Re-usable liner)

If semi-recessed cabinets are required see specification for wall depth's.

**NOTES**



# U5814

## Uni-Door Sanitary Napkin Disposal

Revision 03/11

JOB #:

ITEM #:

QUANTITY:

MOUNTING	HANDING	TYPE	SIZE	OTHER

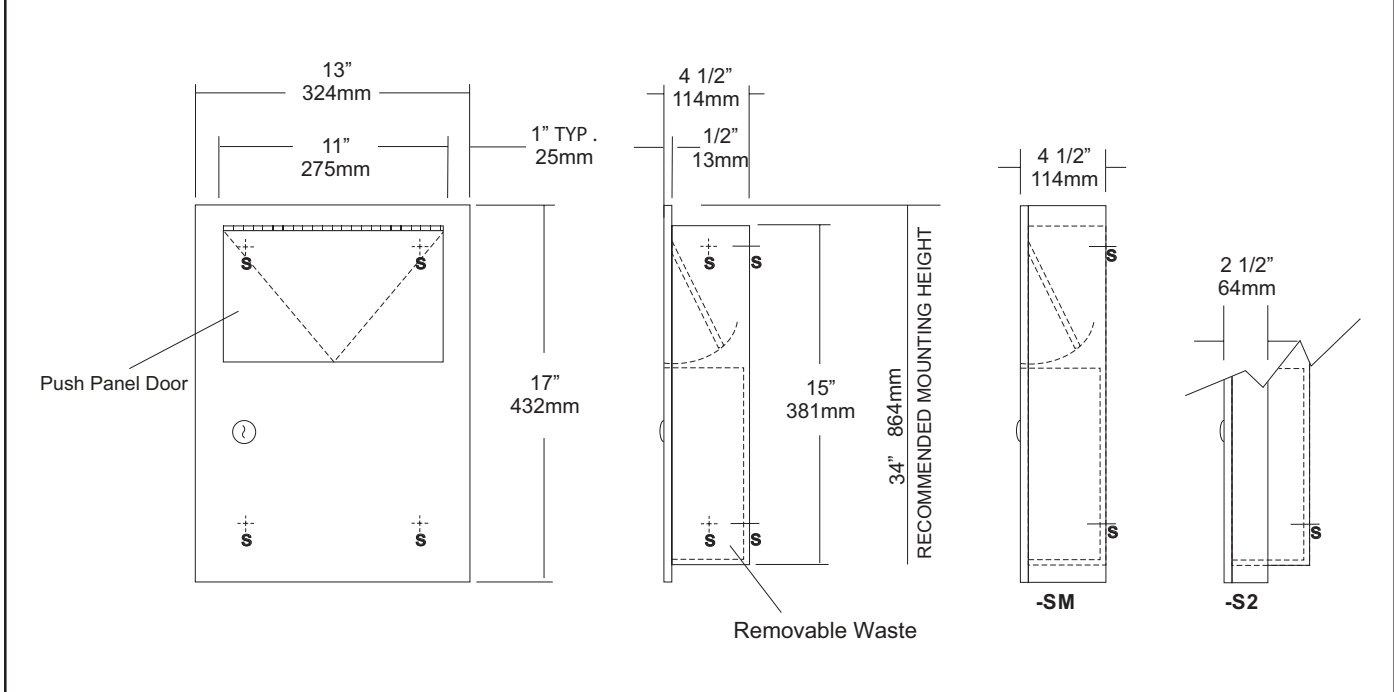

SPECIFICATIONS	INSTALLATION
----------------	--------------

**Body:** Fabricated of #22 ga stainless steel. Face trim is an integral part of the body with a #4 satin finish and 1/4" returns to wall surface for rigidity.

**Uni-Door:** Fabricated of #18 ga stainless steel with a #4 satin finish with 1/2" returns to wall for rigidity.

**Push Panel:** #22 ga stainless steel self closing push panel door.  
\*International Graphic Symbols are optional.

**Waste:** 1.5 gallon removable waste behind door.

**Locks:** Pin tumbler commercial quality locks, keyed like all other AJW cabinets.

**Hinges:** Full length, heavy duty, stainless steel hinge.

**Collars:** #22 ga stainless steel finished and sized to match cabinet.

**Overall Size:** 13"W x 17"H x 4 1/2"D  
**330mm x 432mm x 114mm**

**Wall Opening:** 11 1/2"W x 15 1/2"H x 4"D  
**292mm x 394mm x 108mm**

**Capacity:** 1.5 gallons (.2 cu ft)

**U5814-S2:** semi-recessed Disposal

**Wall Opening:** 11 1/2"W x 15 1/2"H x 2"D  
**292mm x 394mm x 51mm**

**C12174 :** Collar will convert recessed to surf mounted.

Coordinate installation with architect or contractor to avoid interference with pipes, vents, etc. Provide a rough wall opening 11 1/2"W x 15 1/2"H. Verify depth for either the recessed or semi-recessed model. Remove waste from cabinet and secure in opening with proper fasteners for each application making sure unit is level.

**NOTES**

JOB #:

ITEM #:

QUANTITY:

MOUNTING	HANDING	TYPE	SIZE	OTHER

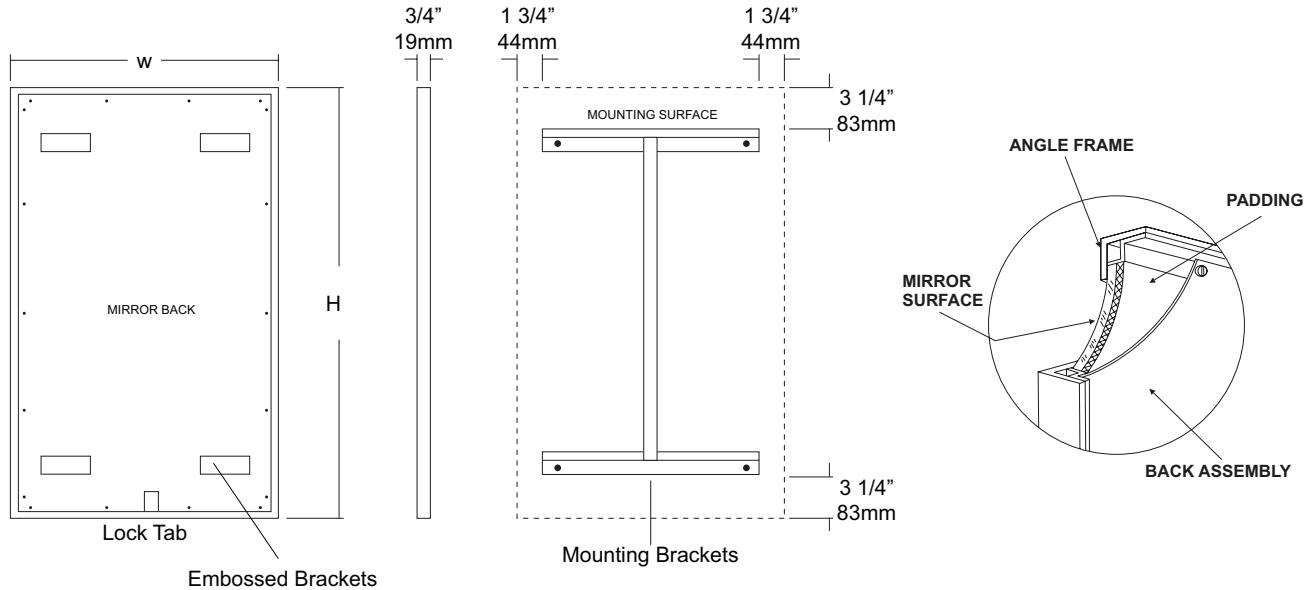

#### SPECIFICATIONS

**Frame:** Fabricated of #18 ga stainless steel, #4 satin finish. 3/4" x 3/4" frame with welded mitered corners are ground and polished smooth. #22 ga concealed "Z" channel is spot welded to inner perimeter of frame for reinforcement and greater rigidity.

**Mirror:** 1/4" thick type 1 transparent flat type, class 1 - clear glass mirrors. Mirror is coated with silver and sealed with a uniform electrolytic copper plating, along with two coats of paint for added protection. Mirrors are guaranteed against silver spoilage for a period of 15 years. Mirrors conform to ASTM C1036 and ASTM C1503-R8.

**Filler:** 3/16" thick full size, shock absorbing, water resistant, non-abrasive polyethylene padding protects all concealed mirror surfaces.

**Back:** #20 ga pre-plated galvanized steel, with embossed horizontal louver mounting brackets. Embossed theft resistant pressure activated clip lock device, locks mirror in place to wall hangers. Back is secured to frame with concealed Phillips head screws.

**Hangers:** Fabricated of #20 ga pre-plated steel galvanized steel with mounting points.

**Standard Sizes Available (W x H):** 16"x24", 16"x20", 16"x30", 18"x24", 18"x30", 18"x36", 20"x60", 24"x30", 24"x36", 24"x42", 24"x48", 18"x60", 24"x60", 24"x72", 18"x72"

#### Options:

- LG:** Laminated Glass
- LX:** Polycarbonate
- PM:** Plastic Acrylic
- T:** Tempered Glass
- VC:** Vinyl Clad (Safety Glass)
- 8B:** #8 Reflective Stainless Steel

\* Stainless steel mirrors reflect images in different optic quality than plate glass. There will be a slight distortion which increases proportionately with the mirror size. Therefore, AJW Architectural Products™ cannot be held responsible for quality of image.

\*\* Mirrors are always ordered Width x Height

\*\*\* Recommended max size for 8B mirrors: 72" x 47-1/2"

\*\*\*\* Framed mirrors are fabricated to a tolerance of (+/-) 1/8"

\*\*\*\*\* Mirrors conform to Federal Specifications DD-M-00411b & DDg-541D.

#### INSTALLATION

Coordinate installation with architect / contractor for specific mounting location and height for each mirror application. Making sure "I" bracket is level, transfer all mounting point locations to wall surface from drawing. Secure brackets with proper fasteners for each application. Slide mirror down over horizontal brackets until clip lock secures mirror in place. Mirror can only be removed by inserting tool through hole at bottom of frame depressing clip. This will allow mirror to slide up over brackets. Fillers are available if mirrors are mounted above and below tile line. (U004 Filler) filler material will match mirror frame to form a one piece construction.

To meet ADA Code, bottom edge of reflective surface can be no higher than 40" above finished floor. (4.19.6) Full length mirrors may be used for universal application when installed in correct locations.

Abrasive cleaners & chloric solutions should not be used on mirrors. Discoloring and /or scratching of frame and reflective surface may occur.

#### NOTES



**U851**  
Seat Cover Dispenser

Revision 07/15

JOB #:

ITEM #:

QUANTITY:

MOUNTING	HANDING	TYPE	SIZE	OTHER

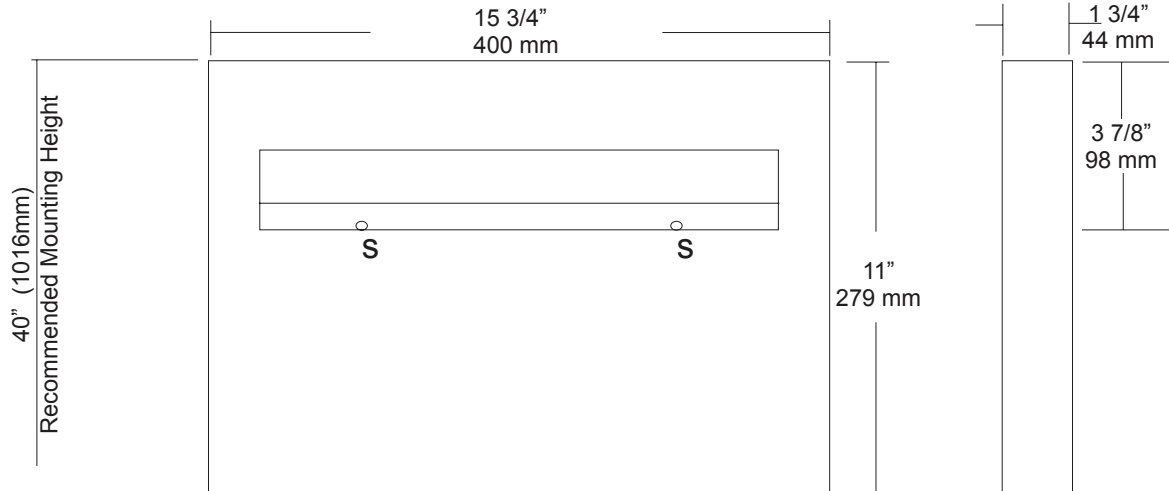

**SPECIFICATIONS**

**Dispenser:** Unit is fabricated of #22 gauge stainless steel with a #4 satin finish. Beveled edge around the dispensing areas ensures a clean dispensing area that prevents product from tearing and injury. Loading of product is accomplished from below without having to open any locking mechanism or access panel. Hat style mounting bracket provides added rigidity for body and acts as a support for the packaging.

**Overall Size:** 15 3/4"W x 11"H x 1 3/4"D

**400mm x 279mm x 44mm**

**Capacity:** 500 seat covers

**INSTALLATION**

Place unit on wall surface at desired or specified location making sure unit is level. Transfer mounting point locations and drill pilot holes for mounting. Secure unit to surface with proper fasteners per application. Product loads from the bottom out of site from public view.

**NOTES**



# UG2-A

Grab Bars

Revised 03/11

JOB #:

ITEM #:

QUANTITY:

MOUNTING	HANDING	TYPE	SIZE	OTHER

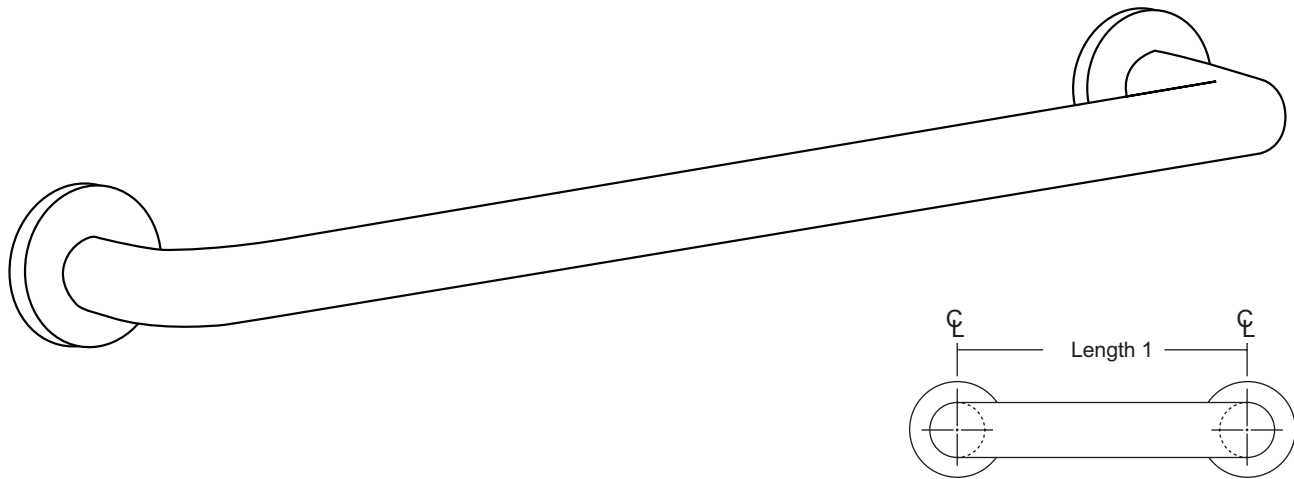

## SPECIFICATIONS & INSTALLATION

**Tubing:** Fabricated of #18 ga stainless steel with a #4 satin finish. Available in 1 1/4" outside diameter. All bends are formed by an automatic mandrel bending process. All bars maintain a constant 1 1/2" offset.

**Finish:** Standard finish is a #4 satin finish. For a non-slip finish (peened) add suffix X to model number. (Ex. UG2X-A)

**Flanges:** Snap flanges are fabricated of 3" diameter, 3/8" deep drawn #22 ga stainless steel with #4 satin finish to match tubing. Flanges have dimples that secure over mounting plate.

**Strength:** Bars with a 1 1/2" offset clearance will support loads in excess of 900lbs when properly installed. Bars with greater offsets will support loads up to 250lbs when properly installed.

**Installation:** Before installing grab bars, verify with all state and local codes for requirements on bar diameter and type finish. Recommended mounting heights for grab bars are 33" - 36" centerline above finished floor. All mounting of grab bars when possible should have in wall mounting back plates. Find centerline mounting points and place bar on line making sure to be on center. Transfer mounting points (3 per flange) to wall. Drill pilot holes and secure bar with proper anchors per application. Snap cover over mounting plate.

**Standard Lengths (Other sizes available upon request):** 12", 16", 18", 24", 30", 32", 36", 42", 48", 50", 52", 54", 56"

## FLANGE INFORMATION

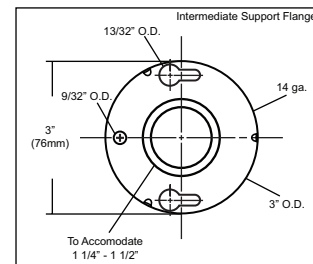
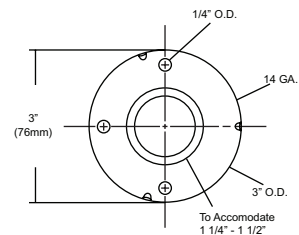
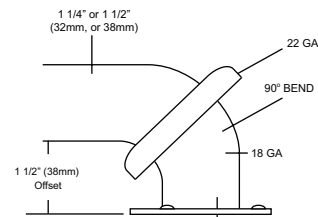

## NOTES