

date
projectname
attn
from
fax
email
phone

1/29/19
RYDER
SHANNON KENNEDY



U125 Soap Dispenser

Revision 11/14

JOB #:

ITEM #:

QUANTITY:

MOUNTING	HANDING	TYPE	SIZE	OTHER

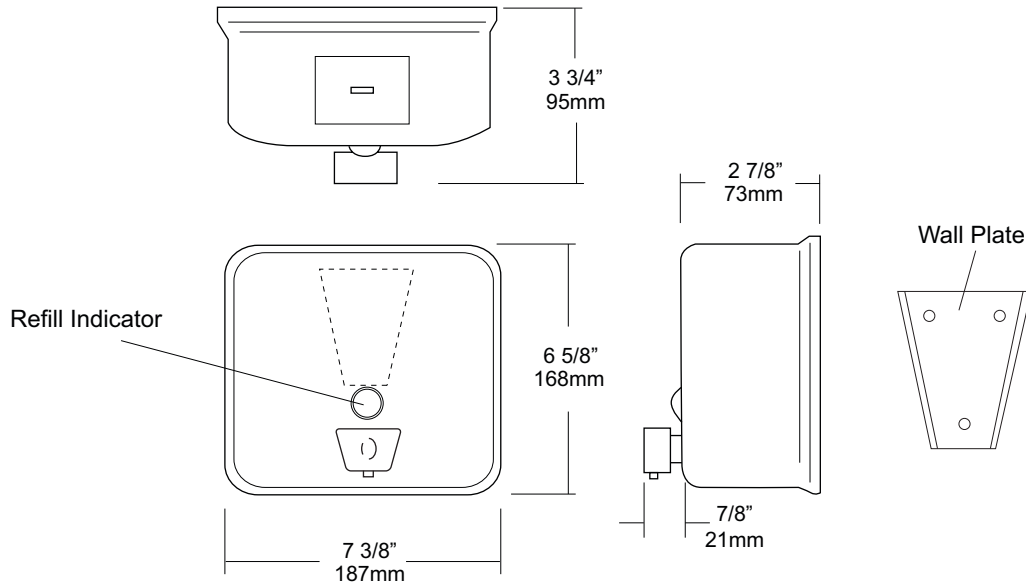

SPECIFICATIONS

Tank: #20 ga stainless steel with satin finish, Drawn one piece construction with a curved front design and radius corners.

Back: #22 gauge stainless steel with #20 gauge stainless steel mounting plate attached. Back plate and tank are welded together to form a one piece unit

Valve: All purpose antibacterial soap valve cylinder, black molded plastic push style valve that takes less than 5 lbs of force and one hand to operate complies with barrier free guidelines when mounted at proper height.

Refill Indicator: Clear plastic viewer window allows a constant fluid level check.

Filler Cap: Fabricated of stainless steel, hinged to allow easy servicing, Cap is secured with special key that creates a vandal resistant dispenser.

Overall Size: 7 3/8"W x 6 5/8"H x 3 3/4"D

187mm x 168mm x 95mm

Capacity: 45 oz

Recommend type soaps without chloric solutions for proper operation.

INSTALLATION

Provide an area on wall surface at desired or specified location, Secure concealed mounting plate to wall surface with proper fasteners, Slide dispenser down over mounting plate and secure by means of a set screw located inside the tank accessible by opening service lid, Fill unit with soap, Secure lid, Prime the valve and test for proper operation.

*It is not recommended to mount any soap dispenser on mirrors

**For best performance, use pre-mixed low concentrate solutions. Dispensers should have periodic maintenance performed to insure the life dispenser. Rinse out globe and valve with warm water to avoid sludge buildup.

Preventative Maintenance: Each dispenser should be flushed out aprx, Every 30 days with warm water to prevent valve from; clogging with old soap, Abrasive cleaners should not be used when wiping down dispenser.

NOTES

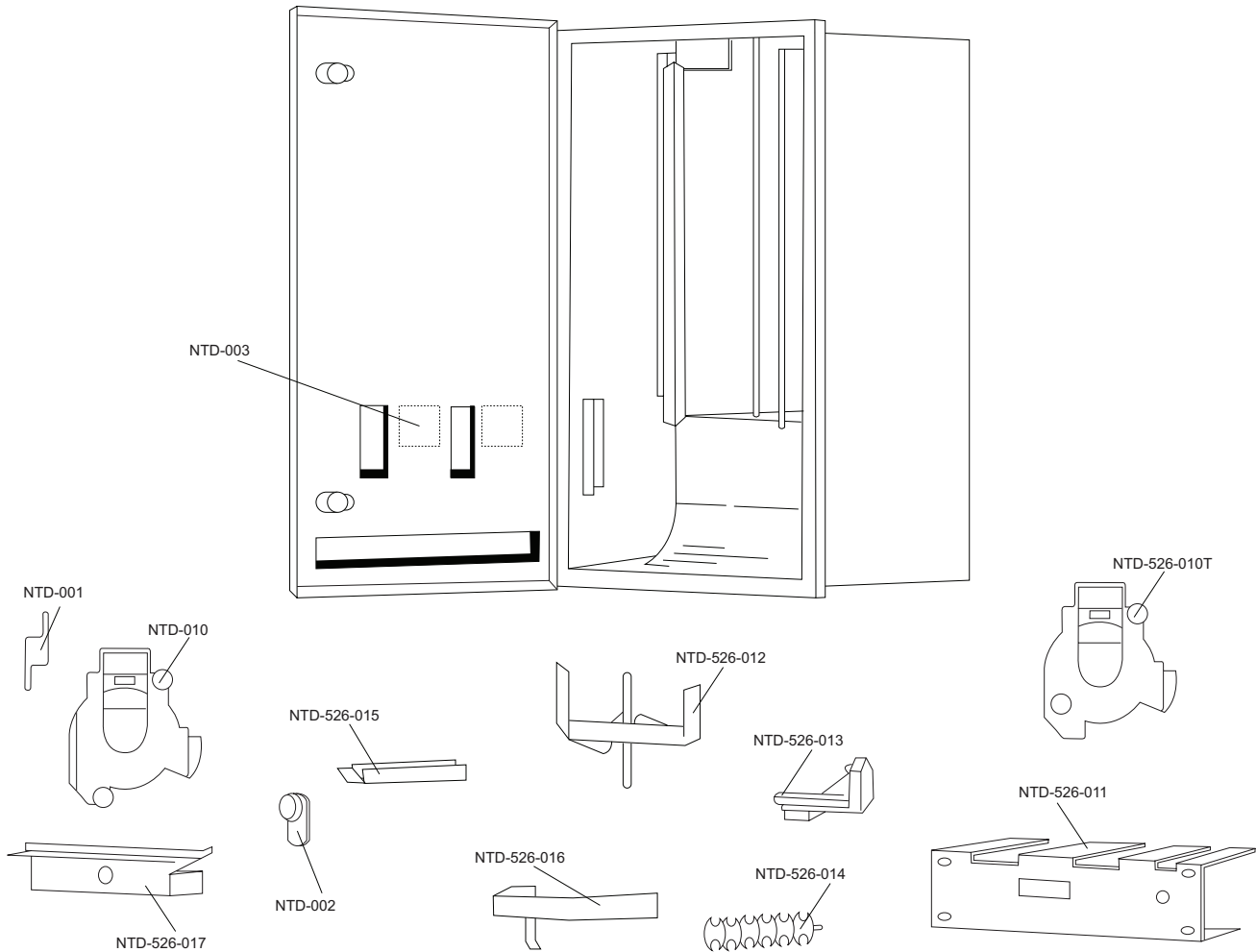

Part Number	Part Description
NTD-001	Turn knob with set screw
NTD-002	HL100 lock & key
NTD-003	Coin & denomination label
NTD-526-011	Mounting plate
NTD-526-012	Two stack finger plate
NTD-526-013	Flipper horn
NTD-526-014	Tampon rotor
NTD-526-015	Tampon weight
NTD-526-016	Napkin weight
NTD-526-10N	Coin mechanism for napkin dispenser only (.10, .25, .50 & Free)
NTD-010	Coin mechanism for tampon dispenser (.10, .25, .50 & Free)
NTD-526-017	Coin box



U5814

Uni-Door Sanitary Napkin Disposal

Revision 03/11

JOB #:

ITEM #:

QUANTITY:

MOUNTING	HANDING	TYPE	SIZE	OTHER

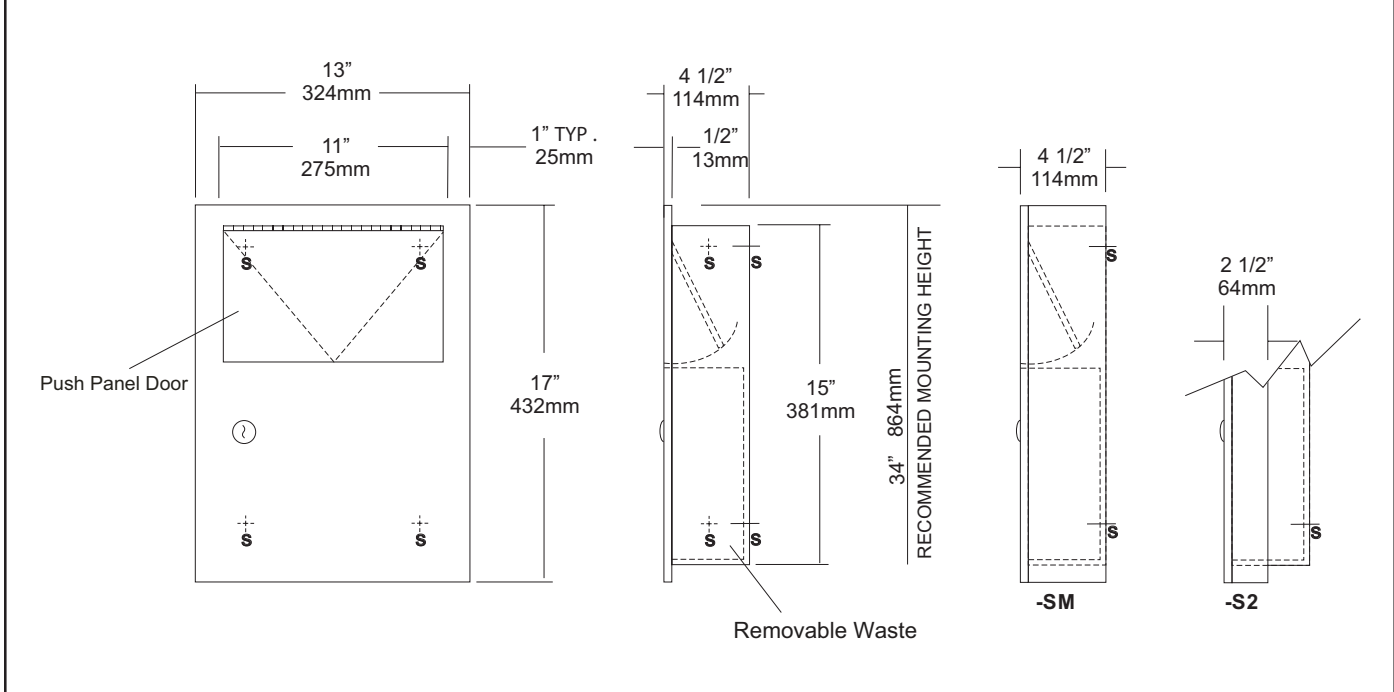

SPECIFICATIONS INSTALLATION

Body: Fabricated of #22 ga stainless steel. Face trim is an integral part of the body with a #4 satin finish and 1/4" returns to wall surface for rigidity.

Uni-Door: Fabricated of #18 ga stainless steel with a #4 satin finish with 1/2" returns to wall for rigidity.

Push Panel: #22 ga stainless steel self closing push panel door.
*International Graphic Symbols are optional.

Waste: 1.5 gallon removable waste behind door.

Locks: Pin tumbler commercial quality locks, keyed like all other AJW cabinets.

Hinges: Full length, heavy duty, stainless steel hinge.

Collars: #22 ga stainless steel finished and sized to match cabinet.

Overall Size: 13"W x 17"H x 4 1/2"D
330mm x 432mm x 114mm

Wall Opening: 11 1/2"W x 15 1/2"H x 4"D
292mm x 394mm x 108mm

Capacity: 1.5 gallons (.2 cu ft)

U5814-S2: semi-recessed Disposal

Wall Opening: 11 1/2"W x 15 1/2"H x 2"D
292mm x 394mm x 51mm

C12174 : Collar will convert recessed to surf mounted.

Coordinate installation with architect or contractor to avoid interference with pipes, vents, etc. Provide a rough wall opening 11 1/2"W x 15 1/2"H. Verify depth for either the recessed or semi-recessed model. Remove waste from cabinet and secure in opening with proper fasteners for each application making sure unit is level.

NOTES



U650

Folded Towel & Waste Combination Unit

Revision 10/14

JOB #:

ITEM #:

QUANTITY:

MOUNTING	HANDING	TYPE	SIZE	OTHER

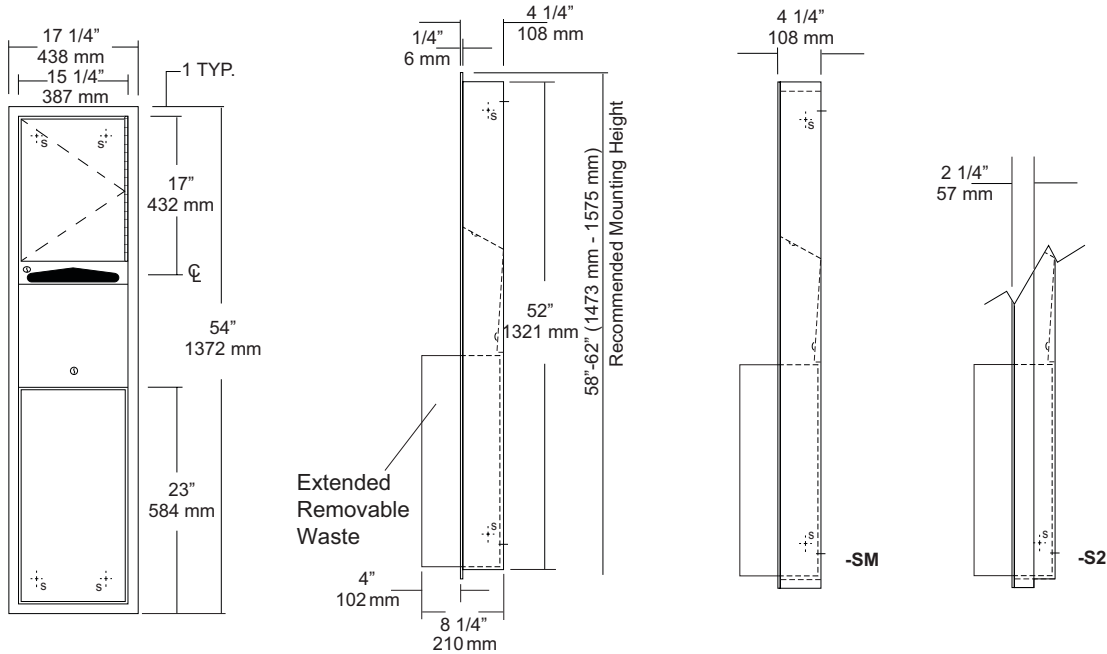

SPECIFICATIONS

Body: Fabricated of #22 ga stainless steel with a #4 satin finish.

Flange: Fabricated of #22 ga stainless steel finished to match cabinet with 1/4" returns. (No miters or welds)

Cabinet Back: Fabricated of stainless steel formed for rigidity with multiple welds to cabinet body.

Cabinet Door: Fabricated of #22 ga stainless steel with #4 satin finish.

Towel Dispenser: Fabricated of #22 ga stainless steel with hemmed edges to prevent injury and towel tearing.

Removable Waste: Fabricated of #22 ga stainless steel #4 satin finish with all leading edges to have a radius. Unit is secured in place by a bottom bracket guide and top lock.

Hinge: Full length, heavy duty, stainless steel piano type hinge.

Locks: Pin tumbler commercial quality, keyed like all other AJW cabinets.

Collars: Fabricated of #22 ga stainless steel, finished to match cabinet. (Used when full recessing cannot be accomplished)

Overall Size: 17 1/4"W x 54"H x 8 1/4"D
438mm x 1372mm x 210mm

Wall Opening: 15 3/4"W x 52 1/2"H x 4"D
400mm x 1334mm x 102mm

U650-S2: semi-recessed. with 2" collar, 2" wall opening 51mm

U650-SM: Full surface mounted collar.

Towel Capacity: 600 c-fold or 800 multifold

Waste Capacity: 12 gallons (1.6 cu ft)

Options :

-VL1: Vinyl Liner

INSTALLATION

Coordinate installation with architect and contractor to avoid interference with pipes, vents, etc. Provide a rough wall opening 15 3/4"W x 52 1/2"H. See chart for required wall depth. If collar is required, slide collar over the back before installing into wall. Remove waste from cabinet and mount unit plumb and true in opening with proper fasteners per application. Secure waste in cabinet and load paper towels.

When cleaning cabinet use a non abrasive non-chloric solution and wiped off with the grain of the cabinet.

NOTES



U705 Series Angle Frame Mirror & Shelf

Revision 11/15

JOB #:

ITEM #:

QUANTITY:

MOUNTING	HANDING	TYPE	SIZE	OTHER

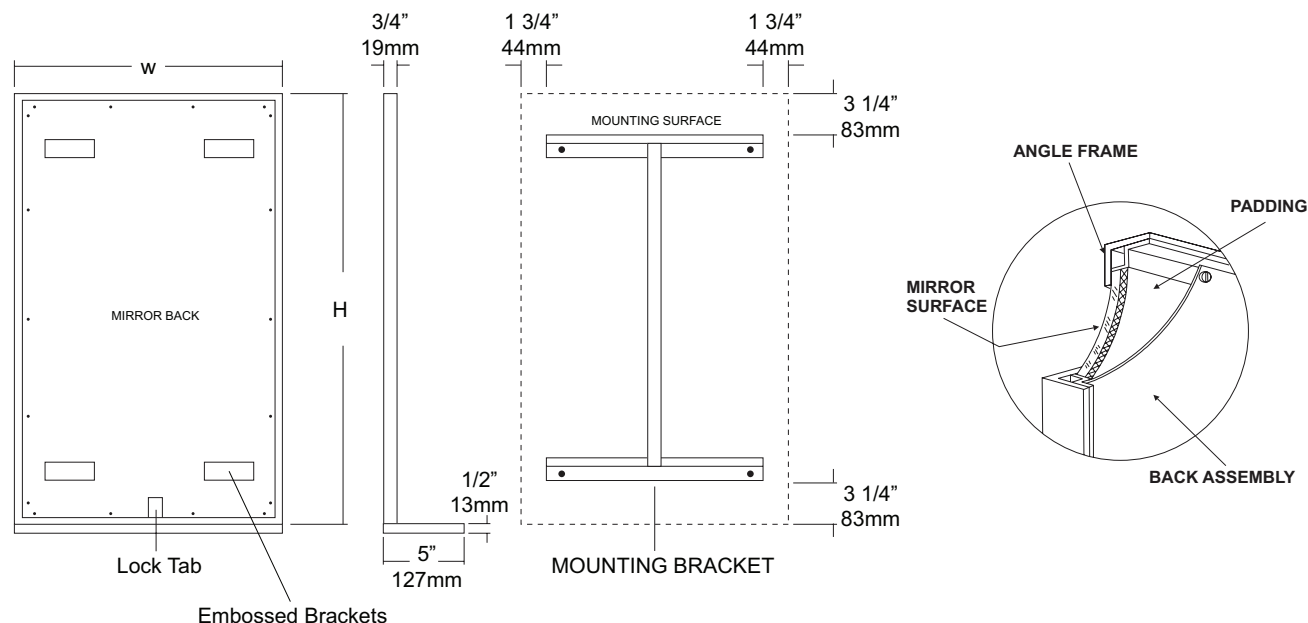

SPECIFICATIONS

Frame: Fabricated of #18 ga stainless steel, #4 satin finish. 3/4" x 3/4" frame with welded mitered corners are ground and polished smooth. #22 ga concealed "Z" channel is spot welded to frame for greater rigidity.

Mirror: 1/4" thick type 1 transparent flat type, class 1 - clear glass mirrors. Mirror is coated with silver and sealed with a uniform electrolytic copper plating, along with two coats of paint for added protection. Mirrors are guaranteed against silver spoilage for a period of 15 years. Mirrors conform to ASTM C1036 and ASTM C1503-R8.

Shelf: #18 ga stainless steel with #4 satin finish. Shelf is 5"D x full width of mirror. All edges are turned down 1/2" with front edge turned back 1/2" for rigidity and prevents possible injury. #18 ga support bracket is welded to both frame and shelf then ground smooth.

Filler: 3/16" thick full size, shock absorbing, water resistant, non-abrasive polyethylene padding protects all concealed mirror surfaces.

Back: #20 ga pre-plated galvanized steel, with embossed horizontal louver mounting brackets. Embossed theft resistant pressure activated clip lock device, locks mirror in place to wall hangers.

Hangers: Fabricated of #20 ga pre-plated galv. steel.

Standard Sizes Available (W x H): 16"x24", 16"x30", 18"x24", 18"x30", 18"x36", 24"x30", 24"x36"

Options:

LG: Laminated Glass

LX: Polycarbonate

PM: Plastic Acrylic

T: Tempered Glass

VC: Vinyl Clad (Safety Glass)

8B: #8 Reflective Stainless Steel

*Stainless steel mirrors reflect images in different optic quality than plate glass. There will be a slight distortion which increases proportionately with the mirror size. Therefore, AJW Architectural Products™ cannot be held responsible for quality of image.

**Mirrors are always ordered Width x Height

***Recommended max size for 8B mirrors: 72" x 47'-1/2"

****Framed mirrors are fabricated to a tolerance of (+/-) 1/8"

***** Mirrors conform to Federal Specifications DD-M-00411b & DD-g-541D

INSTALLATION

Coordinate installation with architect / contractor for specific mounting location and height for each mirror application. Making sure "I" bracket is level, transfer all mounting point locations to wall surface from drawing. Secure brackets with proper fasteners for each application. Slide mirror down over horizontal brackets until clip lock secures mirror in place. Mirror can only be removed by inserting tool through hole at bottom of frame depressing clip. This will allow mirror to slide up over brackets. Fillers are available if mirrors are mounted above and below tile line. (U004 Filler) filler material will match mirror frame to form a one piece construction.

To meet ADA Code, bottom edge of reflective surface can be no higher than 40" above finished floor. (4.19.6) Full length mirrors may be used for universal application when installed in correct locations.

Abrasive cleaners & chloric solutions should not be used on mirrors. Discoloring and /or scratching of frame and reflective surface may occur.

NOTES



U929

Retractable Shower Seat

Revision 1/14

JOB #:

ITEM #:

QUANTITY:

MOUNTING	HANDING	TYPE	SIZE	OTHER

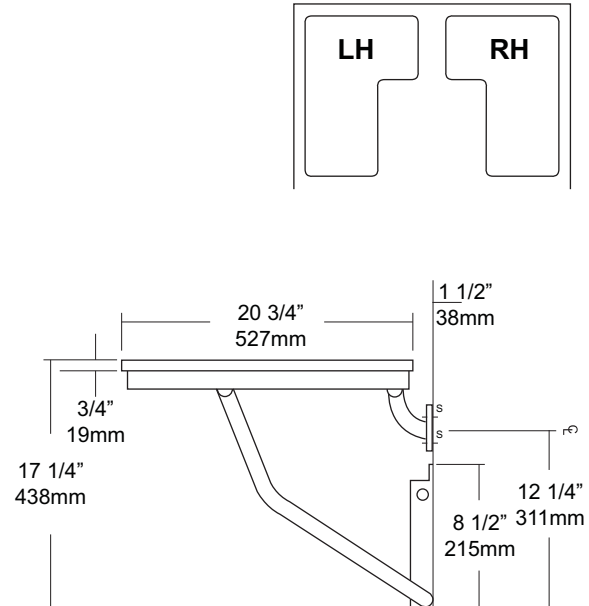
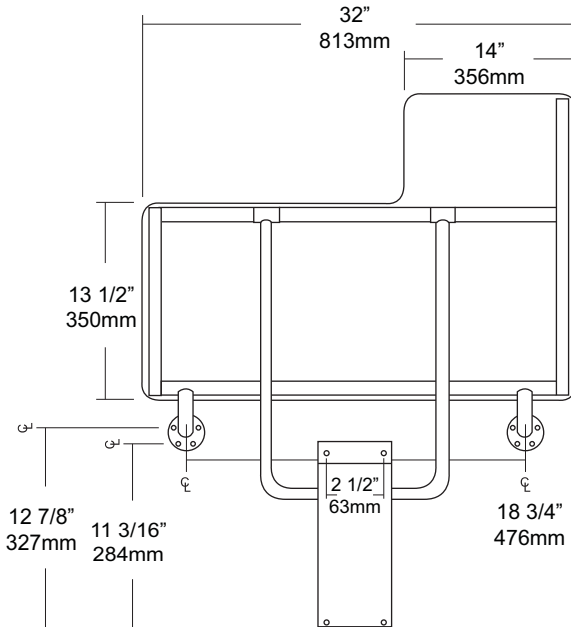

SPECIFICATIONS	INSTALLATION
----------------	--------------

Seat: Fabricated of 3/4" thick, one piece polymers (white) with all leading edges having a radius to prevent injury. Seat is secured to frame with carriage bolts and acorn nuts. Seat is reversible and handing is not required

Tubing: Fabricated of #18 ga stainless steel with #4 satin finish.

Main Frame: 1 1/4" diameter square tubing with capped ends.

Flanges: #18 gauge stainless steel with exposed mounting points. Under slung supports have a 1 1/4" OD

Supports: #18 ga stainless steel 1 1/4" dia diagonal stainless steel support guides for raising and lowering of seat.

Mounting Bracket: #18 gauge stainless steel "hat" style bracket with four (4) mounting points. Bracket acts as a guide for raising and lowering of seat. For maximum support, bracket is mounted resting on floor absorbing load transfer. Seat will remain in an upright position when not in use by means of a spring clip. Seat has been tested to maintain a 500 lb static load.

Overall Size: 32"W x 20 3/4"D (seating area)
813mm x 514mm

***Wall to floor mounting design provides equal distribution of weight to ensure safe operation.**

To comply with ADA Code, seat should be mounted at a height between 17" - 19" above finished floor. Check all state and local codes for building requirements.. Recommend in wall mounting on all shower seats. (BP10) Place seat up against wall making sure the extended part of seat has an offset no more than 1 1/2" away from wall. (Same as grab bar) Transfer mounting points to wall surface and drill pilot holes. Secure seat to surface with proper fasteners for each application. Snugly secure seat to surface and check seat to be level. If seat is level raise and lower seat to check path of travel. Finish securing seat after checking seat for proper operation. When properly mounted seat will support up to 500 lbs and will conform with ADA Code 4.21.3 and 4.26.3. To change handing, remove carriage bolts, switch square length tubing to opposite side and flip deck to change handing and secure with carriage bolts to framing.

Note: This shower seat is not intended to be installed in applications that have shower bases with rounded corners. AJW recommends the U928 for such applications.

NOTES



UG130-A

Grab Bars

Revised 03/11

JOB #:

ITEM #:

QUANTITY:

MOUNTING	HANDING	TYPE	SIZE	OTHER

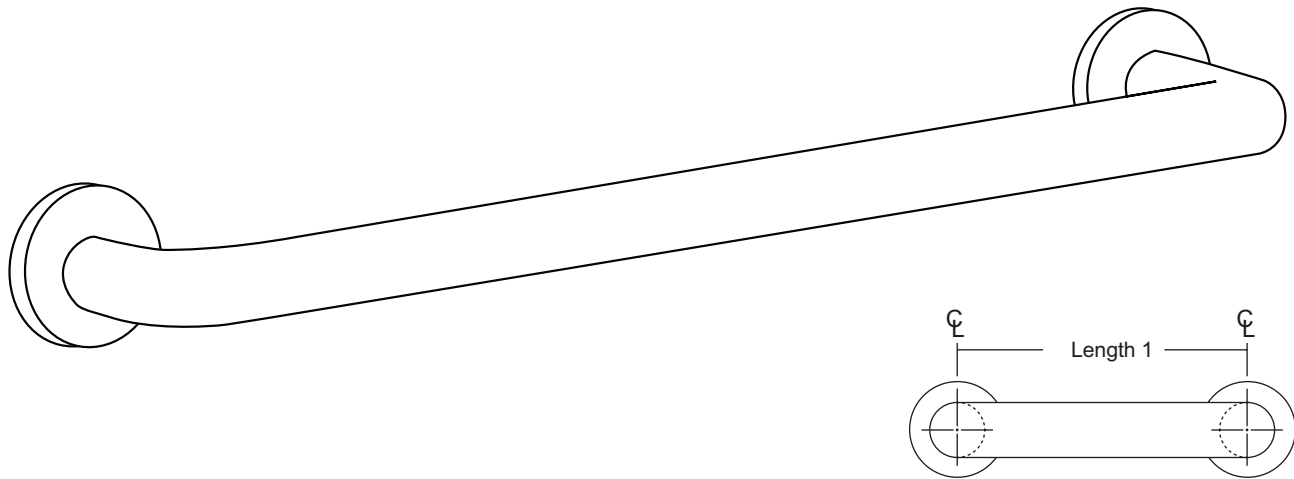

SPECIFICATIONS & INSTALLATION

Tubing: Fabricated of #18 ga stainless steel with a #4 satin finish. Available in 1 1/2" outside diameter. All bends are formed by an automatic mandrel bending process. All bars maintain a constant 1 1/2" offset.

Finish: Standard finish is a #4 satin finish. For a non-slip finish (peened) add suffix X to model number. (Ex. UG130X-A)

Flange: Fabricated of 3" diameter, #11 ga stainless steel with #4 satin finish to match tubing. Flanges are heliarc welded to bar to form a one piece construction. Each flange has three (3) mounting points (1/4" dia.)

Strength: Bars with a 1 1/2" offset clearance will support loads in excess of 900lbs when properly installed. Bars with greater offsets will support loads up to 250lbs when properly installed.

Installation: Before installing grab bars, verify with all state and local codes for requirements on bar diameter and type finish. Recommended mounting heights for grab bars are 33" - 36" centerline above finished floor. All mounting of grab bars when possible should have in wall mounting back plates. Find centerline mounting points and place bar on line making sure to be on center. Transfer mounting points (3 per flange) to wall. Drill pilot holes and secure bar with proper anchors per application.

Standard Lengths (Other sizes available upon request): 12", 16", 18", 24", 30", 32", 36", 42", 48", 50", 52", 54", 56"

FLANGE INFORMATION

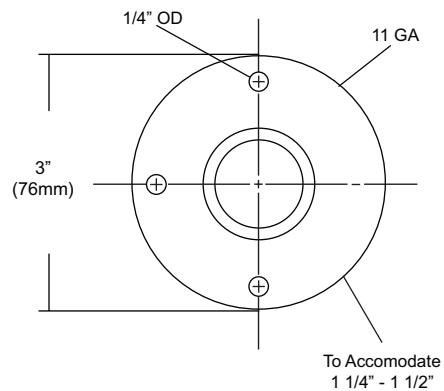
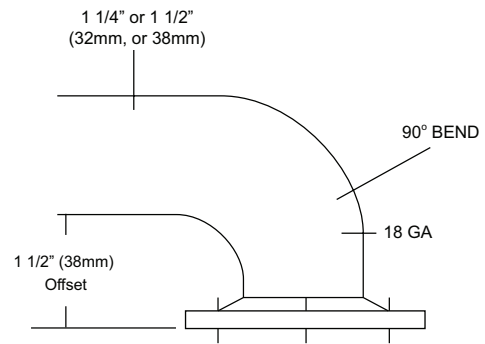

NOTES



UG130-G

Grab Bars

Revised 03/11

JOB #:

ITEM #:

QUANTITY:

MOUNTING	HANDING	TYPE	SIZE	OTHER

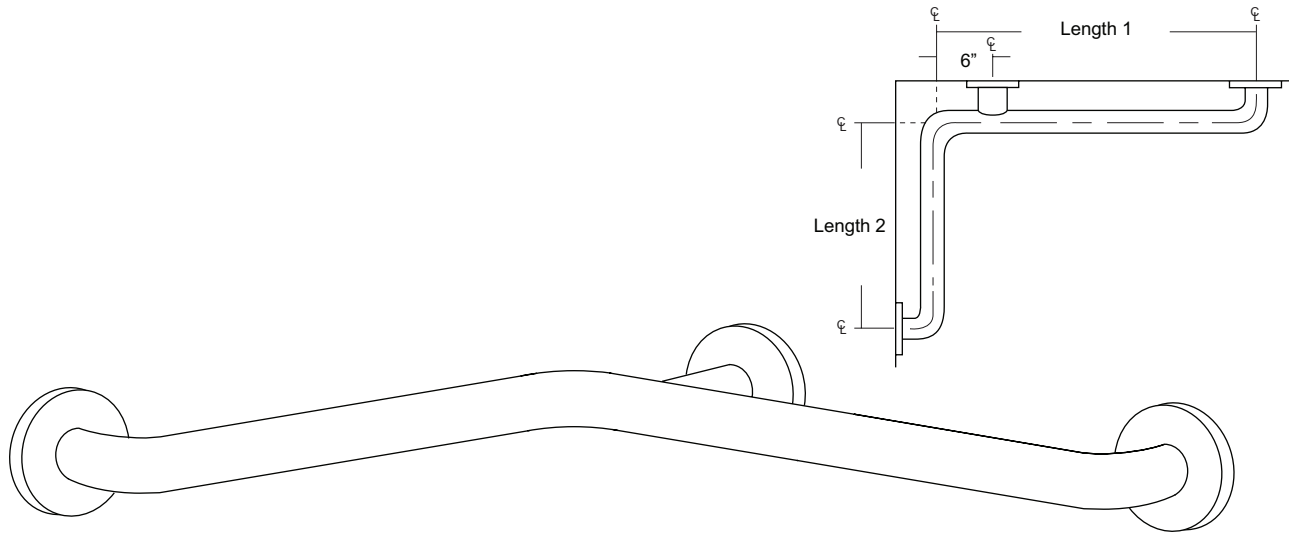

SPECIFICATIONS & INSTALLATION

Tubing: Fabricated of #18 ga stainless steel with a #4 satin finish. Available in 1 1/2" outside diameter. All bends are formed by an automatic mandrel bending process. All bars maintain a constant 1 1/2" offset.

Finish: Standard finish is a #4 satin finish. For a non-slip finish (peened) add suffix X to model number. (Ex. UG130X-G)

Flange: Fabricated of 3" diameter, #11 ga stainless steel with #4 satin finish to match tubing. Flanges are heliarc welded to bar to form a one piece construction. Each flange has three (3) mounting points (1/4" dia.)

Strength: Bars with a 1 1/2" offset clearance will support loads in excess of 900lbs when properly installed. Bars with greater offsets will support loads up to 250lbs when properly installed.

Installation: Before installing grab bars, verify with all state and local codes for requirements on bar diameter and type finish. Recommended mounting heights for grab bars are 33" - 36" centerline above finished floor. All mounting of grab bars when possible should have in wall mounting back plates. Find centerline mounting points and place bar on line making sure to be on center. Transfer mounting points (3 per flange) to wall. Drill pilot holes and secure bar with proper anchors per application.

Standard Lengths (Other sizes available upon request): 30" x 16", 30" x 18", 36" x 18", 36" x 24", 42" x 36", 54" x 36"

FLANGE INFORMATION

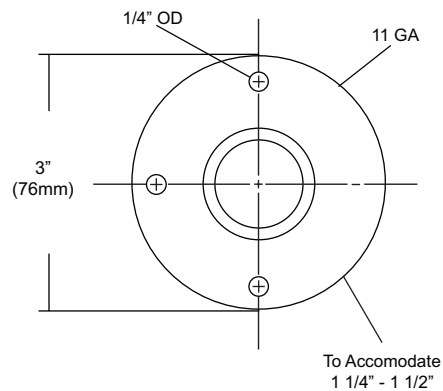
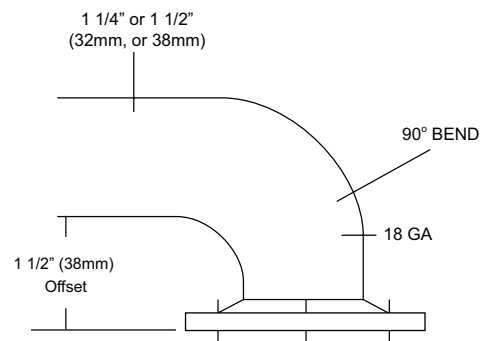

NOTES



UJ41 Series

Mop Holder & Hook Strip Combination Unit

Revision 03/11

JOB #:

ITEM #:

QUANTITY:

MOUNTING	HANDING	TYPE	SIZE	OTHER

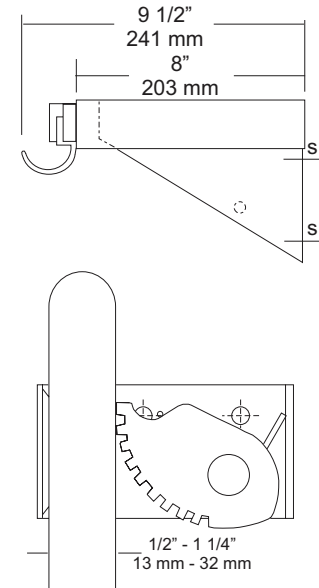
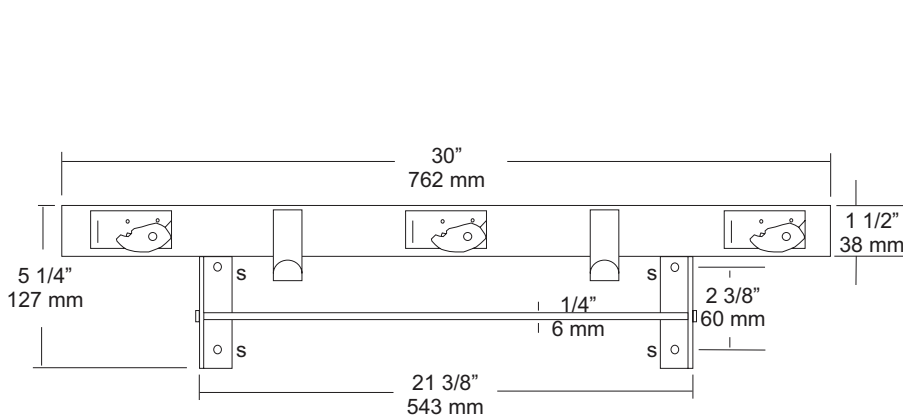

SPECIFICATIONS

Shelf: Fabricated of #18 ga stainless steel with a #4 satin finish, 8" deep (203mm) bent down 1 1/2" with 1/2" returns back for rigidity and safety.

Mop Holders: UJ19 plated reinforced steel with serrated cam type hard rubber mop or broom holder. Holds handles 1/2" to 1 1/4" diameter.

Rag Hooks: Fabricated of #18 ga stainless steel with a #4 satin finish.

Mounting Brackets: #16 ga stainless steel with exposed mounting points.

Drying Rod: 1/4" diameter stainless steel rod, secured to outside of support/mounting brackets with locking caps.

Verify Style:

- UJ41A:** 30"L (762mm) with 3 holders, 2 hooks.
- Rod Length:** 21 3/8" (565mm)
- UJ41B:** 36"L (914mm) with 4 holders, 3 hooks.
- Rod Length:** 27 3/8" (692mm)
- UJ41C:** 42"L (1066mm) with 5 holders, 4 hooks.
- Rod Length:** 33 3/8" (845mm)
- UJ41D:** 48"L (1219mm) with 6 holders, 5 hooks.
- Rod Length:** 39 3/8" (997mm)

INSTALLATION

Place unit to wall surface making sure unit is level and transfer mounting points. Drill pilot holes and secure unit with proper fasteners per application.

NOTES



UX142-BF

Toilet Tissue Dispenser

Revision 10/14

JOB #:

ITEM #:

QUANTITY:

MOUNTING	HANDING	TYPE	SIZE	OTHER

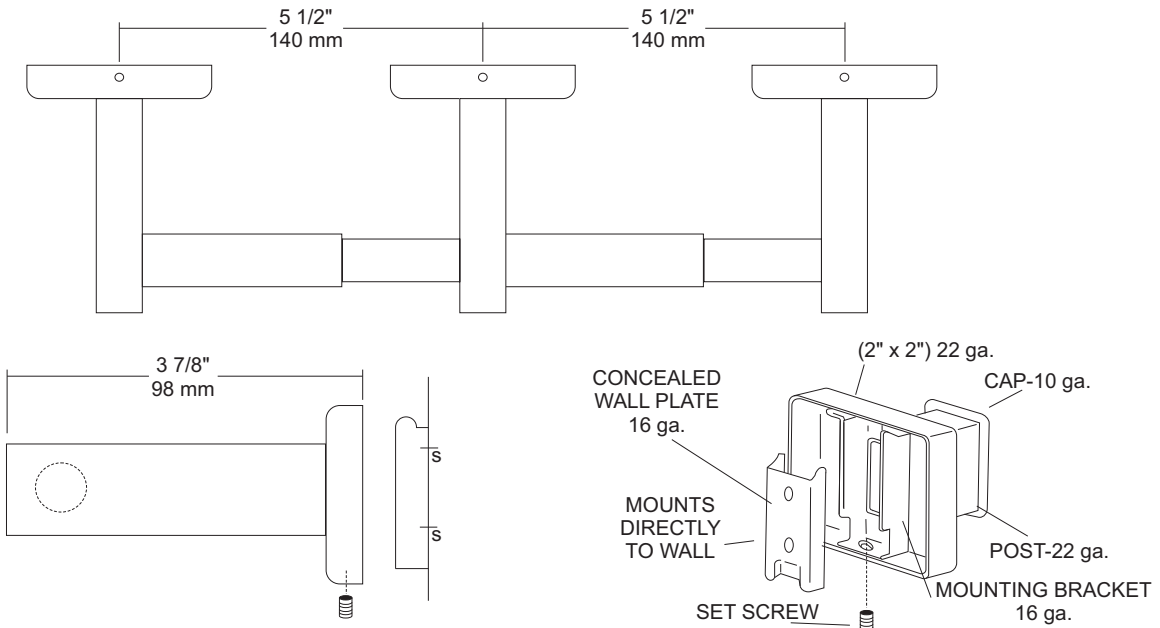

SPECIFICATIONS

UX Accessories: All UX bath accessories series are fabricated of stainless steel with a bright or satin finish. Mounting plates are concealed with a snap-on type plate secured by a set screw.

Flange: 2" x 2" flange #22 ga stainless steel.

Post: #22 ga stainless steel.

Mounting Plate: #16 ga concealed wall plate. Set screw secures mounting plate and flange.

Spindle: Spring loaded, chrome plated plastic.

Optional U007 Theft Resistant Adapter: Prevents spindle from being removed until roll has been depleted.

Overall Size: 13" W x 2"H x 3 7/8"D

330mm x 51mm x 98mm

UX142-SF: Same as UX142-BF with satin finish

INSTALLATION

Provide an area on wall surface at desired or specified location. Place concealed mounting plate on wall surface and transfer mounting points. Drill pilot holes and secure with proper fasteners. Place snap-on flange over plate and secure with set screw. Centerline space between posts is aprx. 5 1/2"W. Repeat same steps for other post. Place a roll of tissue on spindle and place in posts before securing the covers down securely. If roll spins freely, secure post with set screw. All toilet tissue dispensers must have a non-control delivery to meet ADA code. (4.16)

NOTES



UX1C

Flange & Shower Rod

Revision 03/11

JOB #:

ITEM #:

QUANTITY:

MOUNTING	HANDING	TYPE	SIZE	OTHER

To Accomodate
1" O.D. Shower Rod

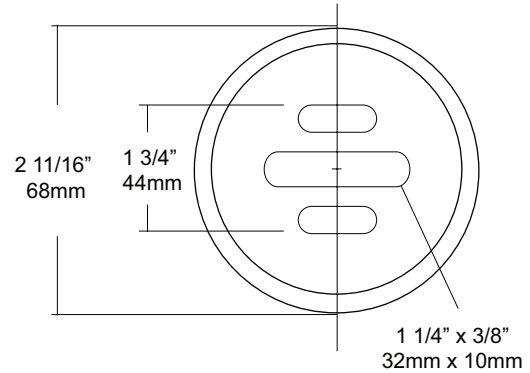
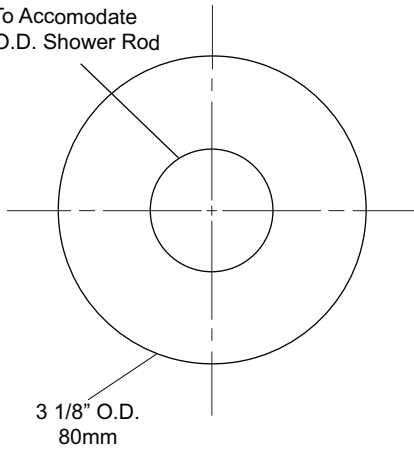

SPECIFICATIONS

Set Screw Cover: Fabricated of #11 gauge stainless steel with a #4 satin finish, secured with four (4) set screws.

Flanges: Fabricated of 3" diameter, 1/2" drawn #11 ga stainless steel with #4 satin finish to match tubing. Flanges are heliarc welded to bar to form a one piece construction. Each flange is secured to concealed mounting plate with four (4) 1/4"-20 stainless steel tamper resistant set screws.

Shower Rod: Fabricated of 18 gauge stainless steel with a #4 satin finish.

UX1: 1" outside diameter

INSTALLATION

Provide an area on wall surface at desired or specified location. Hold flange to wall surface and transfer mounting points. Drill pilot holes. Place flanges on the ends of the rods. Secure flanges to wall surface with proper fasteners per application.

NOTES



UX1K

Flange & Shower Rod

Revision 03/11

JOB #:

ITEM #:

QUANTITY:

MOUNTING	HANDING	TYPE	SIZE	OTHER

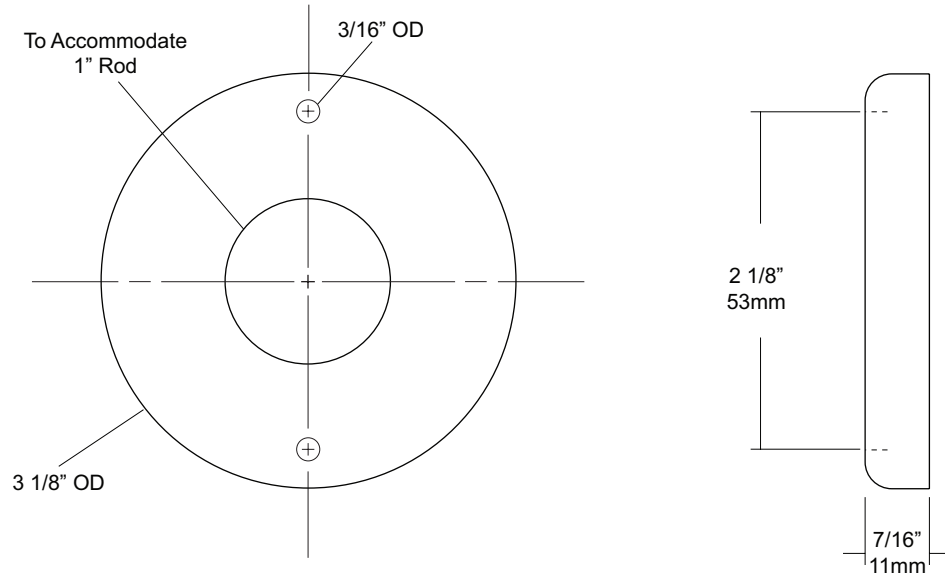

SPECIFICATIONS	INSTALLATION
----------------	--------------

Exposed Cover: Fabricated of #22 gauge stainless steel with a #4 satin finish. Cover has two (2) exposed mounting points.

Shower Rod: Fabricated of 18 gauge stainless steel with a #4 satin finish.

UX1: 1" outside diameter

Provide an area on wall surface at desired or specified location. Hold flange to wall surface and transfer mounting points. Drill pilot holes. Place flanges on the ends of the rods. Secure flanges to wall surface with proper fasteners per application.

NOTES

UX250P Vinyl Shower Curtain

Installation & Cleaning Instructions

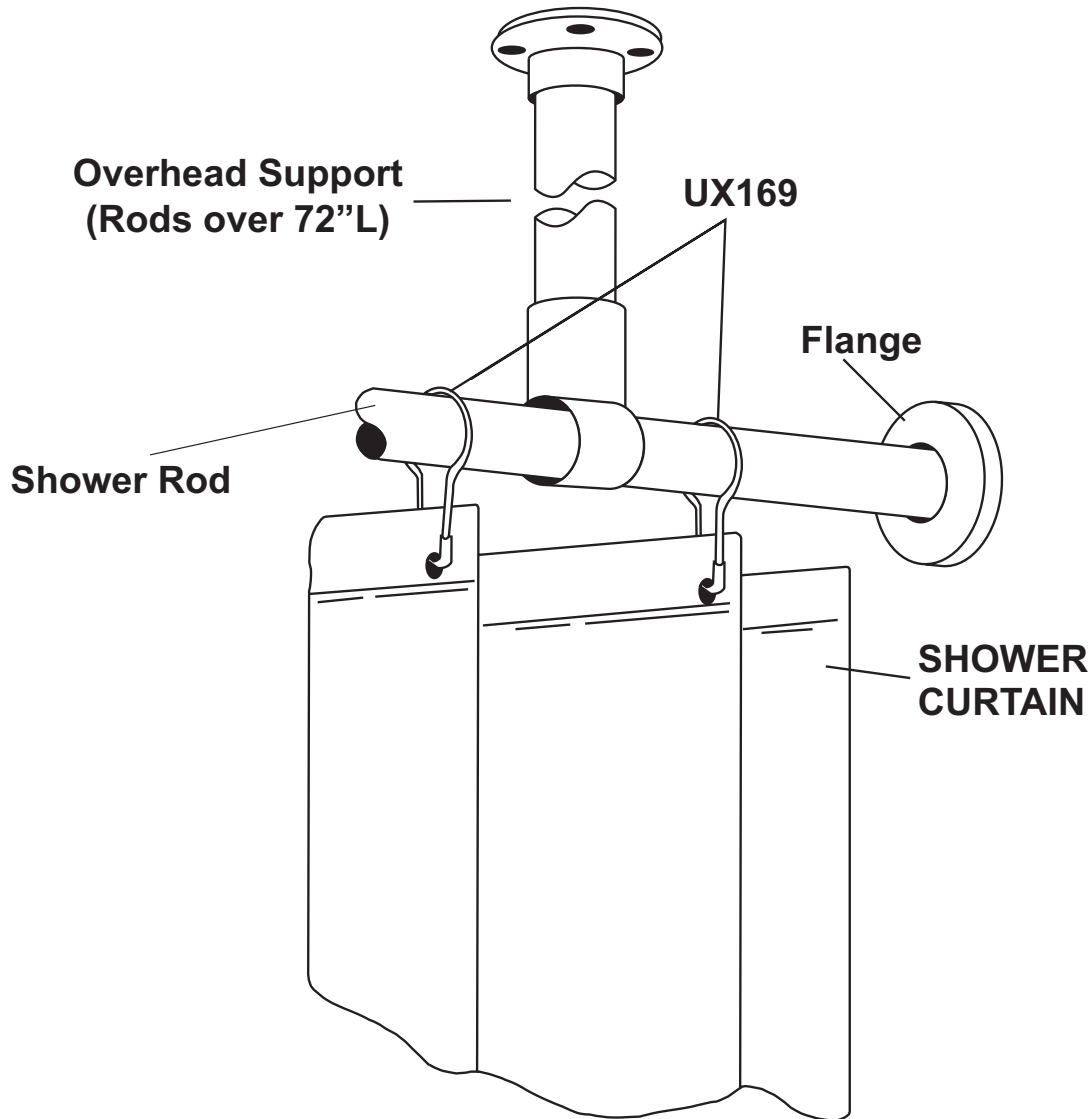

INSTALLATION

Recommended: UX169 stainless steel shower curtain hooks to connect to AJW shower curtain rods. Various types of flanges are available to secure rod and curtain to mounting surface (exposed and concealed).

Measuring Curtains: Curtains are measured W x H. The same curtain will fit a 1 or 1 1/4" diameter rod.

CARE & CLEANING

Machine wash cold water (not exceeding 41°C / 105°F). Do not bleach. Do not dry clean. Tumble dry low (not exceeding 140°F). Remove promptly.

JOB #:

ITEM #:

QUANTITY:

MOUNTING	HANDING	TYPE	SIZE	OTHER

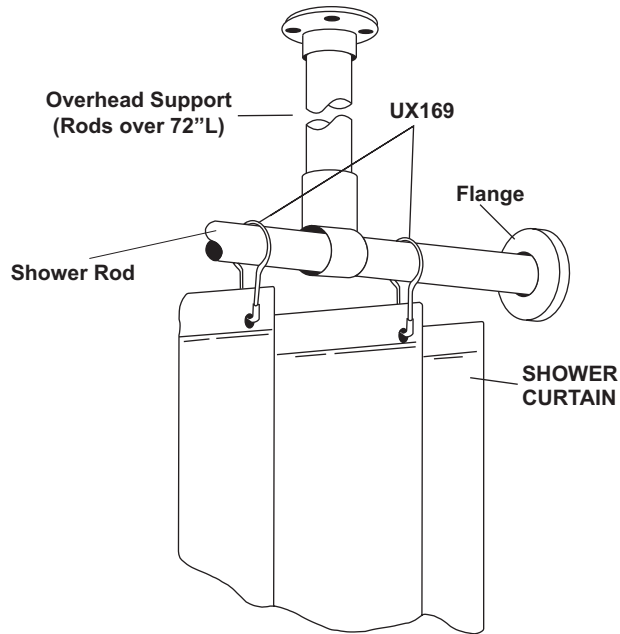

SPECIFICATIONS	INSTALLATION
----------------	--------------

Bacteria & Mildew Resistant: Heavy duty vinyl film (8 mil) that is flame retardant, durable and waterproof. Microbiotic KV-33 is an integral part added to the fabrication of this curtain that can be laundered repeatedly without losing this barrier against bacteria, fungus and mildew. KV-33 is a durable bacteriostat, mildewstat and fungistat that will provide protection for as long as you use this style curtain. It will retard the growth of organisms, thereby inhibiting odors caused by decaying bacteria.

Design: To insure the ultimate in bacteria free curtain, there are no side hems to hinder the flow-off of soap and water. This also makes cleaning easier. The heading is reinforced with a ten gauge vinyl film with rust proof anodized eyelets spaced 6" apart.

Cleaning: Sponge with warm mild soap and rinse with clear water.

Machine washing: Relatively cool water temp not to exceed 120 degrees F. DO NOT USE DETERGENTS. Air dry at low temp. Colors: Standard stock color is white. Special order for other colors are available on request.

***UX1-V/UX2-V:** Overhead s/s supports for oversized shower rods. (For shower rods over 72" in length an overhead support is recommended)

UX1-V: 1" OD shower rods.

UX2-V: 1 1/4" OD shower rods.

Recommended: UX169 stainless steel shower curtain hooks to connect to AJW shower curtain rods. Various types of flanges are available to secure rod and curtain to mounting surface (exposed and concealed).

Measuring Curtains: Curtains are measured W x H. The same curtain will fit a 1 or 1 1/4" diameter rod.

NOTES

Formerly Model #: 250P