

date
projectname
attn
from
fax
email
phone

12/30/20
Destrehan High School Gym Reno and Addition
Tabb
Brittany Correa-Rivera

brittany@cisairproducts.com
2253471690

Care, Cleaning, and Maintenance Instructions – Washroom Accessories

With proper care and cleaning, as well as routine maintenance, you will help to maximize the life of your AJW accessories. Please refer to these procedures when maintaining our products:

Stainless Steel Surfaces:

Wipe stainless steel cabinets with a soft cloth, rubbing with the grain to prevent scratching the surface. The grain of AJW's stainless steel cabinets runs in a vertical direction. Do not use abrasive cleaners containing chloric solutions on stainless steel. Avoid cleaning products that contain hydrochloric acids, bleach, or chlorides.

Soap Dispensers:

The majority of operational issues with soap dispensers are due to improper maintenance and lack of cleaning. Soap tanks, valves, and globes should be cleaned periodically to avoid sludge and soap build up, thus promoting better operation. When soap dispensers are left unmaintained for long periods of time, the soap could potentially dry out inside the valve mechanism, causing clogs or leaking. While cleaning, do not remove or take valves apart as this creates problems with the seals and may cause a bypass leak. Flush valves with warm water. If the water does not flow through the valve after cleaning, repeat the procedure until it does.

Take care to make sure you are using the right soap in your soap dispensers. The proper viscosity is imperative for trouble free operation. AJW recommends that the soap viscosity should be at least 95 cps, and no more than 2500 cps for use in all AJW soap dispensers. Coconut oil soaps should be the only products used in liquid valve soap dispensers. We recommend that you use a standard liquid, non-chloric soap, which should be mixed in a solution of one part water to one part soap. We recommend free-flowing, thin viscosity soaps only.

JetAir Hand Dryers:

Begin the cleaning procedure by disconnecting the electrical supply. Using the allen key supplied, remove all tamper-resistant screws and lift the cover of the dryer off of the base, and clear dust and lint from the inside of the machine and cover. When you have finished cleaning, reinstall the cover onto the base and secure with tamper-resistant screws. Wipe cover with a damp cloth; do not use abrasive cleaners. Clean the inner cover and internal mechanism periodically to ensure proper operation.

Note: Hand Dryer maintenance that is performed inside the cover should not be done by unqualified personnel.

Mirrors:

Wipe mirror frames with a soft cloth, making sure to rub stainless steel frames with the grain to avoid scratching. Do not use abrasive cleaners containing chloric solutions on stainless steel frames.

Mirror glass should be cleaned by spraying cleaner on a soft cloth, and then wiped onto the mirror (it is best if cleaner is not sprayed directly onto the mirror). This will ensure that cleaning agents do not run down the mirror and into the frame. If a cleaning agent and/or still water is allowed to sit in a frame or on the back of a mirror, it will lead to a de-lamination of the protective coating, and/or the mirror silver, voiding the AJW warranty.

Note: Soap dispensers should not be mounted directly on a mirror surface, as soap residue and water from a person's hand can be splashed into the mirror frame, causing the same de-lamination as described above.

Corrosive Chemical / Surface Rust Alert

Stainless steel is very resistant to rust, however it is not entirely impervious to it. Proper care, especially under corrosive conditions is needed. Cleaning your stainless steel surface using the instructions above is necessary, but it is also important to keep your stainless steel surface free from contaminants.

The below listed substances will react with stainless steel to produce rust and corrosion. These elements are commonly used in caustic cleaning agents, and should never be used to clean stainless steel washroom accessories. The most common elements that react adversely with stainless steel include:

Bromide
Chloride
Fluoride
Iodine

Other common acids and compounds cause significant damage to stainless steel. Stainless steel will sustain permanent discoloration and/or corrosion if the material comes into contact with even vapor fumes from these substances. The following acids and compounds should never be used to clean any stainless steel product:

Acetic Acids
Nitric Acids
Phosphoric Acids
Hydrochloric / Muriatic Acids
Sodium Chlorides (contains salt)
Sodium Hydrochloride (Bleach)
Sodium Hydroxide
Sulfuric Acids



Some other conditions that can cause stainless steel to corrode, discolor, or develop surface rust are:

1. Contact with Muriatic Acid (commonly used to clean up after tile or concrete installation).
2. Soap residue (chemical additives will cause discoloration and dried soap residue actually looks like rust).
3. Water with high iron content can leave a rusty residue, especially after continuous contact.

Surface Rust Removal

If your stainless steel surface is exposed to any of the contaminants above, please follow the instructions below to remove any discoloration:

- Wash affected accessory with a mild dish detergent and warm water.
- Dry all surfaces with a towel or soft cloth.
- Using a dry Scotch Brite pad, rub all surfaces until rust marks are completely removed. Be sure to rub in the direction of the grain to prevent scratching. Grab bars may be cleaned using a rotating motion, as the grain is random in these products. Do not use on bright polish stainless steel.
- Rinse with a damp cloth and dry with a soft cloth.



LEED Credit Information – Washroom Accessories

As intimidating as LEED certification may seem, we know that a little extra help goes a long way. That's why the AJW collection includes various products that can help you come closer to earning your LEED certification. While LEED doesn't certify products, using recycled, sustainable, and energy-efficient products earns you points in the LEED program.

The LEED credit information for AJW Washroom Accessories is as follows:

- **Sourced Material:** Stainless steel sourced within a 500 mile radius. Our stainless steel products will help with your eligibility toward MR Credits 5.1 and 5.2 if your project is within 500 miles of our manufacturing facility in New Windsor, NY and the original source, Pittsburgh, PA.
- **Raw material:** All AJW stainless steel products are made up of between 55% and 65% recycled material. 35% of our stainless steel is recycled pre-consumer and 25% is recycled post-consumer. Our stainless steel will help with your eligibility toward MR Credits 4.1 and 4.2.
- **Plastics:** All plastic AJW baby changing stations are made up of 50% recycled polyethylene, and AJW HD plastic retractable shower seat decks are made of 35% pre-consumer recycled polymers. Our plastic materials will help with your eligibility toward MR Credits 4.1 and 4.2.
- **Packaging:** Our corrugated cardboard packaging is made up of 87% post-consumer recycled material.
- **Glass:** All glass used in AJW mirrors are made up of 20% pre-consumer recycled materials.



U1521EA Series

Stainless Steel Hands Free Dryer

Revision 11/14

JOB #:

ITEM #:

QUANTITY:

MOUNTING	HANDING	TYPE	SIZE	OTHER

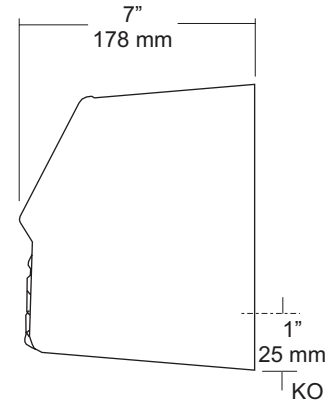
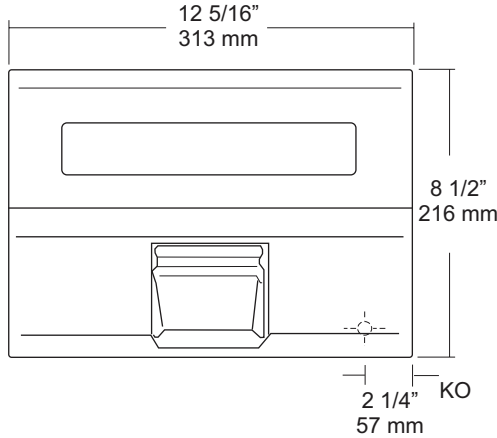
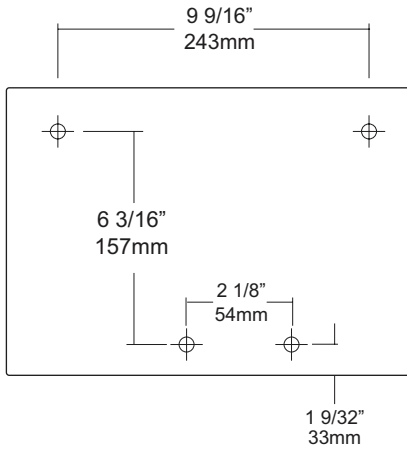

SPECIFICATIONS

Motor: Brushless, 1/8 hp, 3450 RPM capacitor initiated with non-lubricating bearings and thermally protected against over heating. 66.1 dB.

Fan: Dynamically balanced to eliminate vibration & noise.

Heating Element: Dynamically balanced to eliminate vibration & noise. 2300 watt nichrome coil would element on state of the art convective cooling system. Ambient temp produced at nozzle is 70 degrees F.(21 C) Unit is protected by an integral thermal safety circuit breaker.

Timer: Fully enclosed, non-mechanical timer, that automatically turns off when hands are moved away from path of sensor.

Electric Eye: Sensor allows a hands free operation. When sensor beam path is disturbed, dryer will automatically turn on. When hands move away from beam, dryer stops.

Cover: Fabricated of #18 ga stainless steel, #4 satin finish, spot welded to form one piece unibody construction. Cover is secured to base with two tamper resistant fasteners. Special key provided to remove cover. All seams polished smooth.

Nozzle: Fixed chrome plated nozzle that can be changed from fixed to 2 position in the field.

Base: One piece #14 ga steel with 3/4" returns to wall surface for maximum strength and rigidity.

Unit	Volts	Amps	Cycles	Cover
U1521EA	120V	110-120	20 60	S/S
U1521EA	230V	220-230	10 60	S/S

Overall Size: 12 5/16"W x 8 1/2"H x 7"D
313mm x 216mm x 178mm

INSTALLATION

Coordinate installation with contractor, architect and licensed electrician. Transfer mounting points to wall surface with supplied templates. Check all code requirements for proper mounting heights. Secure base with proper fasteners for each application. Properly connect power supply to dryer. Test dryer for operation. Secure cover to base with supplied theft resistant fasteners(2). Test dryer again after cover is secured. Dryers have a full five (5) year warranty to original purchaser against defective materials and workmanship. Unit must be installed by a qualified licensed electrician.

Mounting	Hands	Hair
Men	46" (1168mm)	73" (1854mm)
Women	44" (1118mm)	68" (1727mm)
Physically Impaired	38" (965mm)	46" (1168mm)
Children 6-10	34" (864mm)	43" (1092mm)
Children 11-14	42" (1067mm)	56" (1422mm)

*Above are recommended mounting heights from lower mounting point above the finished floor.

NOTES

Formerly Model #: U1521EA



U775 Series
Surface Mounted Shelf

Revision 07/11

JOB #:

ITEM #:

QUANTITY:

MOUNTING	HANDING	TYPE	SIZE	OTHER

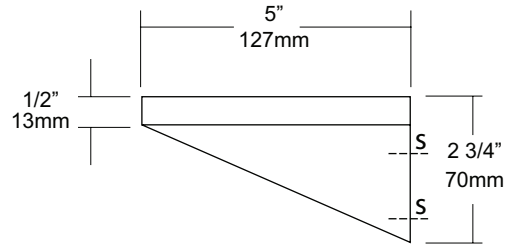
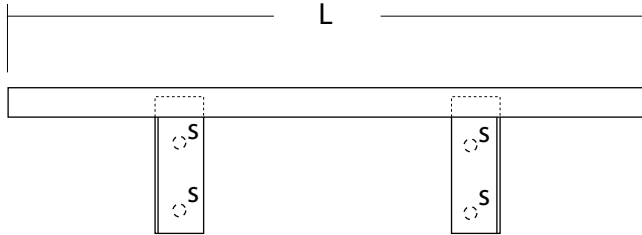

SPECIFICATIONS

Shelves: Fabricated of #18 ga stainless steel. All edges are turned down 1/2" with front edges turned down & back 1/2" for maximum strength and rigidity. All corners are deburred and polished smooth for safety.

Brackets: Fabricated of #16 ga stainless steel permanently welded to shelf with exposed mounting points. Brackets are spaced maximum 30" centerline.

Surface mounted shelf 5"D (127mm)

INSTALLATION

Provide an area on wall surface at desired or specified location. Place unit up to wall making sure unit is level. Transfer mounting points to surface and drill pilot holes. Secure shelf to surface with proper fasteners per each application.

NOTES



UJ13 Series

Mop Holder Strip & Shelf Combination Unit

Revision 03/11

JOB #:

ITEM #:

QUANTITY:

MOUNTING	HANDING	TYPE	SIZE	OTHER

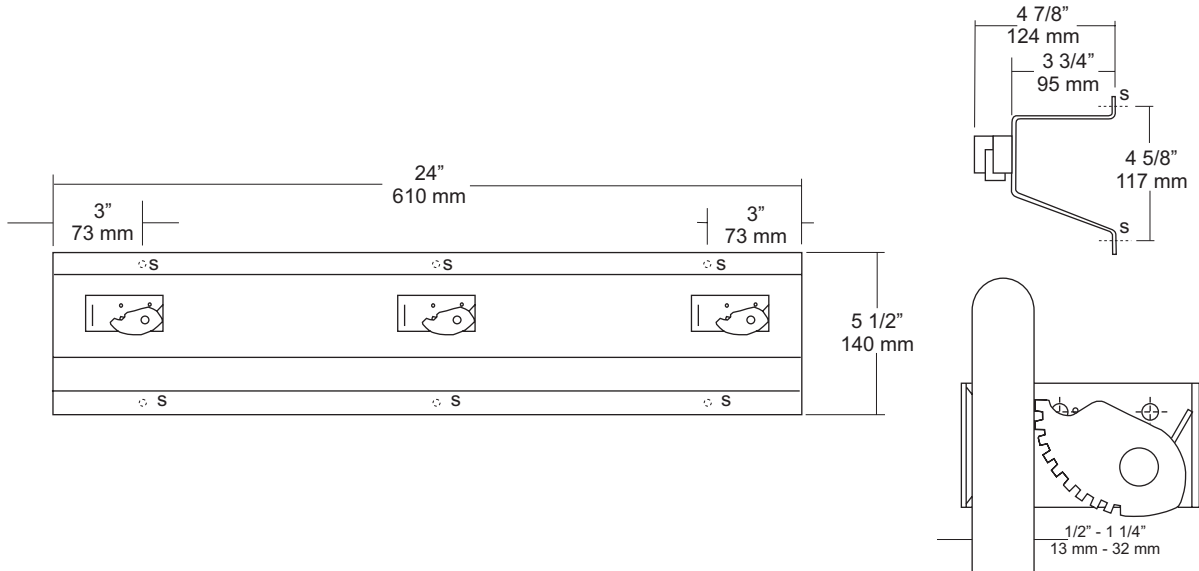

SPECIFICATIONS	INSTALLATION
----------------	--------------

Mop Strip & Shelf: Fabricated of #18 ga stainless steel with a #4 satin finish. Upper portion of strip is formed in the shape of a "hat" channel, that is utilized as a shelf, projects 3 3/4" from wall surface. Lower portion is angled to add rigidity and strength to strip.

Mop Holders: UJ19 plated reinforced steel with serrated cam type hard rubber mop or broom holder. Holds handles 1/2" to 1 1/4" diameter.

Verify Style:

- UJ13A:** 24"L (610mm) with 3 holders.
- UJ13B:** 36"L (914mm) with 4 holders.
- UJ13C:** 48"L (1219mm) with 5 holders.
- UJ13D:** 60"L (1524mm) with 6 holders.

Place unit to wall surface making sure unit is level and transfer mounting points. Drill pilot holes and secure unit with proper fasteners per application.

NOTES



Warranty – Washroom Accessories

Accessories

AJW guarantees its Washroom Accessories to be free of material defects, and defects from workmanship for a period of one (1) year from the date of shipment.

Baby Changing Stations

AJW baby changing stations are guaranteed for five (5) years from the date of shipment.

Mirrors

We guarantee our mirrors against silver spoilage for a period of fifteen (15) years under normal use. This guarantee includes all ¼” plate glass mirrors including tempered, laminated, and all other ¼” safety glass mirrors.

Hand Dryers

Our Jet Air hand dryers are warranted to be free of defects from workmanship under normal use and maintenance for a period of five (5) years from date of shipment (with the exception of the U1511EA which has a warranty period of two (2) years from date of shipment). Hand dryer warranty info is as follows:

- U1511EA- 2 Year Limited Warranty, Motor Brushes 2 Years, Eye Sensor One Year
- U1512EA- 5 Year Limited Warranty, Motor Brushes 2 Years, Eye Sensor One Year
- U1521EA- 5 Year Limited Warranty, Eye Sensor One Year
- U1525EA- 5 Year Limited Warranty, Eye Sensor One Year

This warranty excludes defects in the Washroom Accessory caused by: vandalism, improper use, improper installation, neglect, and environmental damage.

If the Washroom Accessory is found to be defective in workmanship or materials within the warranty period, AJW will replace all affected components, free of charge. AJW will not be responsible for any other expenses including, but not limited to: removal costs, installation costs, freight costs, or any other costs associated with the repair or replacement of the product.

The replacement or repair of defective material as stated in this warranty shall constitute the sole remedy of the buyer and the sole liability of AJW under this warranty. AJW shall not be liable for any incidental, consequential, or indirect damages caused by the failure or defect in the material supplied, or any delay in the replacement or repair of warranty items.

Warranty claims must be made during the warranty period, and communicated to AJW by contacting AJW Architectural Products at: 509 Temple Hill Road – New Windsor, NY 12553 – Phone: 845-562-3332.