

date
projectname
attn
from
fax
email
phone

1
sas
saasa
1



U8504

Uni-Door Seat Cover Dispenser

Revision 05/11

JOB #:

ITEM #:

QUANTITY:

MOUNTING	HANDING	TYPE	SIZE	OTHER

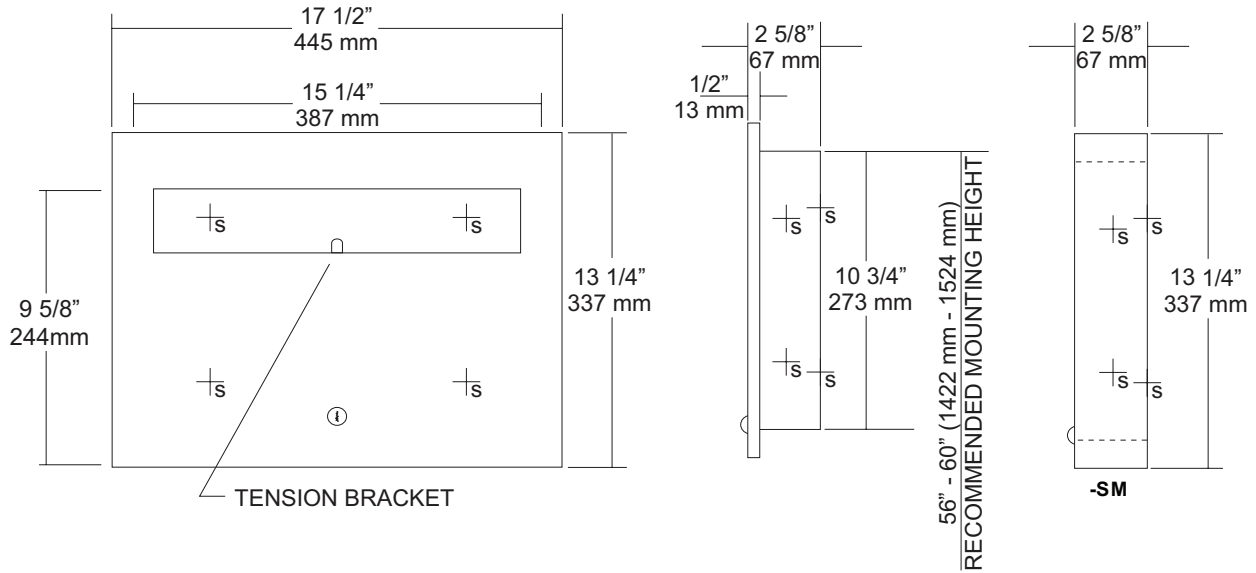

SPECIFICATIONS

- Body:** Fabricated of #22 gauge stainless steel with a #4 satin finish on all exposed surfaces.
- Flange:** #22 gauge stainless steel with 1/4" returns to wall without any miters.
- Uni-Door:** #18 ga stainless steel door. Seat cover dispensing area (on both units) are deburred and polished smooth to avoid paper tearing and injury.
- Hinge:** Full length, stainless steel piano type hinge.
- Lock:** Pin tumbler commercial quality, keyed like all other AJW cabinets.
- Overall Size:** 17 1/2"W x 13 1/4"H x 2 5/8"D
445mm x 337mm x 68mm
- Wall Opening:** 15 3/4"W x 11 1/4"H x 2 5/8"D
400mm x 286mm x 60mm
- U8504-SM:** Surface mounted unit
- Capacity:** 500 seat covers

INSTALLATION

Provide required wall opening at desired or specified location with coordination with architect or contractor to avoid interference with pipes, vets, etc. Unlock cabinet and place unit in opening. Secure to rough framing with proper fasteners per each application. Fill dispenser with product and secure cabinet door.

NOTES



U851 Seat Cover Dispenser

Revision 07/15

JOB #:

ITEM #:

QUANTITY:

MOUNTING	HANDING	TYPE	SIZE	OTHER

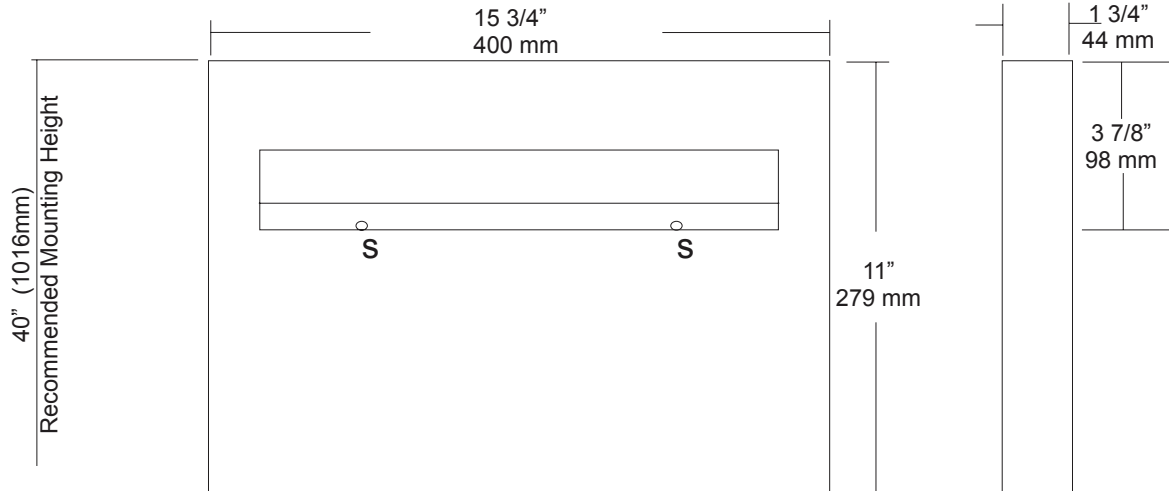

SPECIFICATIONS

Dispenser: Unit is fabricated of #22 gauge stainless steel with a #4 satin finish. Beveled edge around the dispensing areas ensures a clean dispensing area that prevents product from tearing and injury. Loading of product is accomplished from below without having to open any locking mechanism or access panel. Hat style mounting bracket provides added rigidity for body and acts as a support for the packaging.

Overall Size: 15 3/4"W x 11"H x 1 3/4"D

400mm x 279mm x 44mm

Capacity: 500 seat covers

INSTALLATION

Place unit on wall surface at desired or specified location making sure unit is level. Transfer mounting point locations and drill pilot holes for mounting. Secure unit to surface with proper fasteners per application. Product loads from the bottom out of site from public view.

NOTES



U860

Seat Cover, Sanitary Napkin Disposal &
Toilet Tissue Dispenser Combination Unit

Revision 03/11

JOB #:

ITEM #:

QUANTITY:

MOUNTING	HANDING	TYPE	SIZE	OTHER

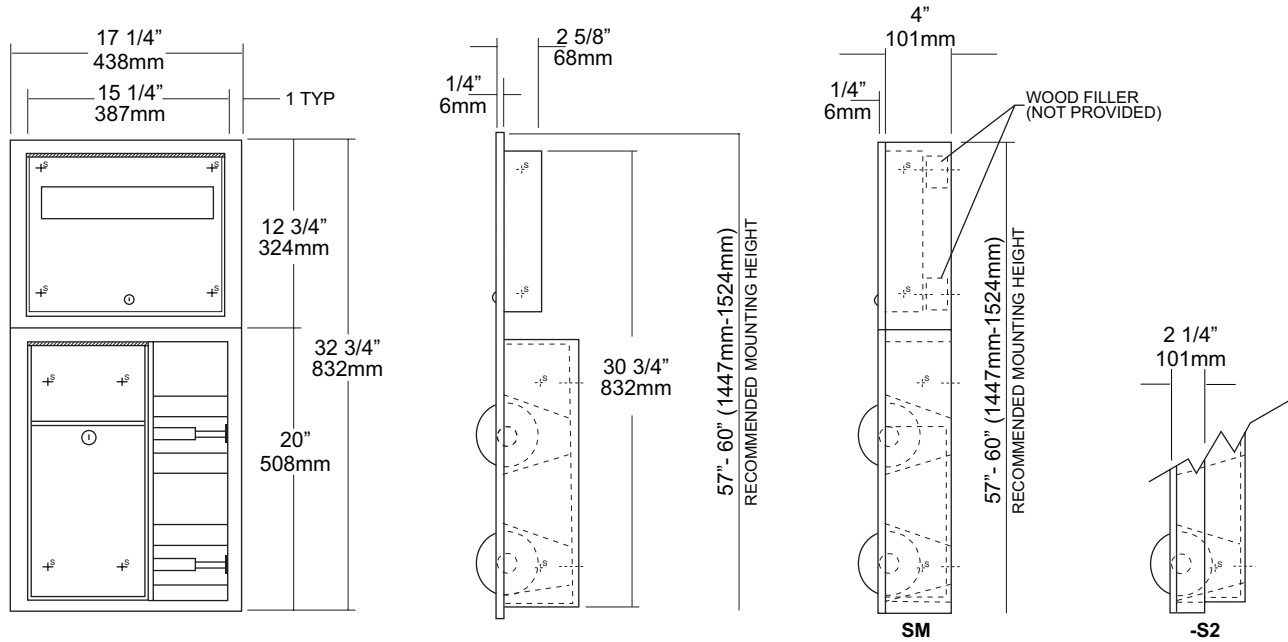

SPECIFICATIONS

Cabinet: Fabricated of #22 gauge stainless steel. All exposed surfaces have a #4 satin finish.

Flange: Fabricated of #22 gauge stainless steel one-piece drawn seamless construction. No seams or exposed miters with 1/4" returns to wall surface.

Napkin Disposal: Self closing push panel door is fabricated of #22 gauge stainless steel. Removable Waste is fabricated of same material with pin tumbler lock. Waste is identified with International Graphic symbol.

Toilet Tissue Dispenser: #22 gauge stainless steel hat adapters secure chrome plated, spring loaded rollers in place.

U007 Theft Resistant Adapter: Prevents spindle from being removed until roll has been depleted.

Seat Cover Dispenser: #22 gauge stainless steel secured by pin tumbler lock.

Hinges: All hinges are full length, heavy duty, stainless steel piano type hinges.

Collars: #22 ga stainless steel finished to match cabinet.

Overall Size: 17 1/4"W x 32 3/4"H x 4 1/4"D
 438mm x 832mm x 108mm

Wall Opening: 15 3/4"W x 31 1/4"H x 4"D
 400mm x 793mm x 102mm

U860-S2: 2" semi-recessed. collar, 2" wall opening, 51 mm

U860-SM: Full surface mounted collar.

Waste Capacity: 2 Gallons (.26 cu ft)

Toilet Tissue: Two standard rolls with a 5 1/4" (133mm) OD.

Seat Cover Capacity: 500

INSTALLATION

Provide rough wall opening at desired or specified location of 15 3/4"W x 31 3/4"H. (Depth of opening will depend on type mounting required.) Place lower unit in opening. Before securing place seat cover dispenser in opening to ensure proper fit. If both units fit properly in opening, secure bottom unit than the top. If collars are required, place collar onto the units from the back before securing to mounting area. Fill seat cover dispenser and toilet tissue rolls.

Toilet Paper Dispensers: All dispensers that are to meet ADA code cannot have any type of controlled delivery. (4.16)

NOTES