

date
projectname
attn
from
fax
email
phone

11/11/20
BLDG 2064
JAY DAVENPORT
Charlie Mills

jay@adelaideservicesllc.com



U126 Soap Dispenser

Revision 11/14

JOB #:

ITEM #:

QUANTITY:

MOUNTING	HANDING	TYPE	SIZE	OTHER

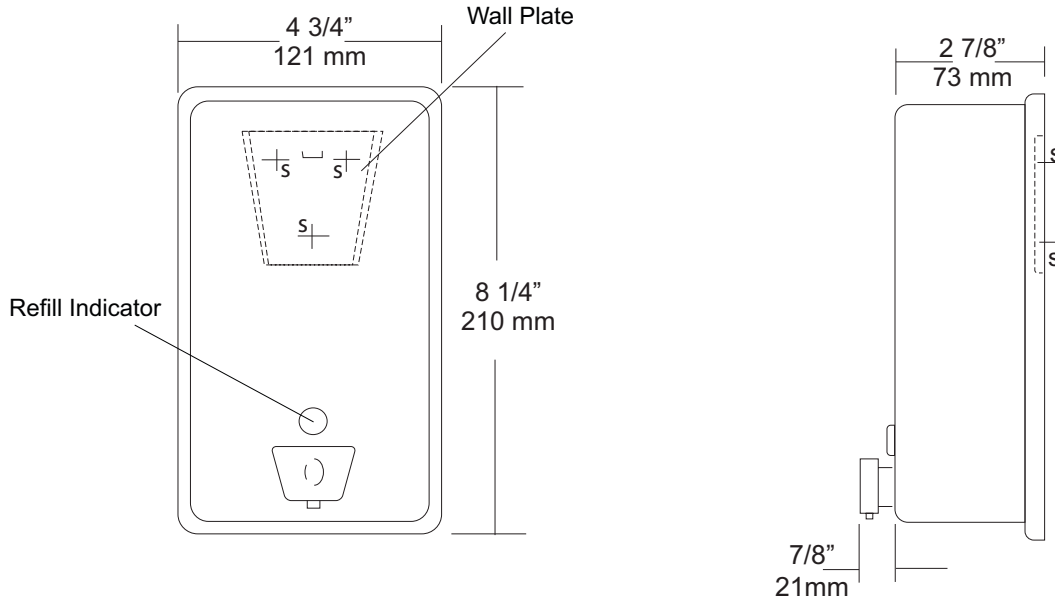

SPECIFICATIONS

Soap Tank: Fabricated of #20 ga stainless steel, #4 satin finish, fully welded one-piece construction.

Valve: All purpose antibacterial soap valve cylinder, black molded plastic push style valve that takes less than 5 lbs of force and one hand to operate complies with barrier free guidelines when mounted at proper height.

Viewer: Clear plastic window allows a constant fluid level check.

Concealed Mounting Plate: Fabricated of heavy gauge stainless steel.

Filler Cap: Fabricated of stainless steel, hinged to allow easy servicing, secured with special key that creates a vandal resistant dispenser.

Overall Size: 4 3/4"W x 8 1/4"H x 3 3/4"D (wall to valve)

121mm x 210mm x 95mm

Capacity: 40 oz.

Recommend type soaps without chloric solutions for proper operation.

INSTALLATION

Provide an area on mounting surface at desired or specified location. Secure concealed mounting plate to wall surface with proper fasteners. Slide dispenser down over mounting plate and secure by means of set screw located inside tank. Fill unit with proper soap. Close lid and secure with special key. Test valve for proper operation.

*It is not recommended to mount any soap dispenser on mirrors

**For best performance, use pre-mixed low concentrate solutions. Dispensers should have periodic maintenance performed to insure the life dispenser. Rinse out globe and valve with warm water to avoid sludge buildup.

Preventative Maintenance: Each dispenser should be flushed out aprx. Every 30 days with warm water to prevent valve from clogging with old soap. Do not use abrasive cleaners to clean dispenser.

NOTES



U1521EA Series

Stainless Steel Hands Free Dryer

Revision 11/14

JOB #:

ITEM #:

QUANTITY:

MOUNTING	HANDING	TYPE	SIZE	OTHER

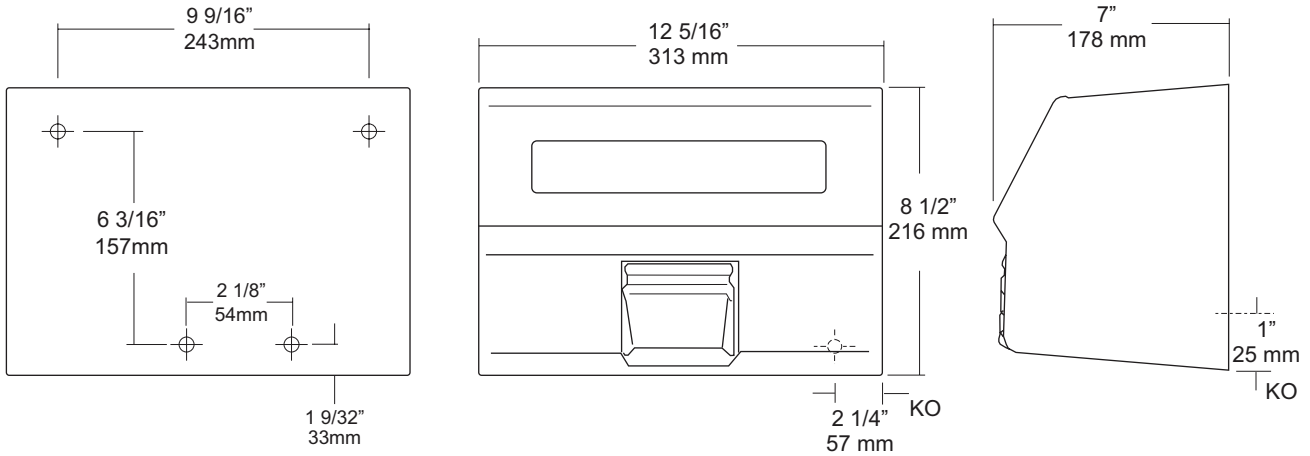

SPECIFICATIONS

Motor: Brushless, 1/8 hp, 3450 RPM capacitor initiated with non-lubricating bearings and thermally protected against over heating. 66.1 dB.

Fan: Dynamically balanced to eliminate vibration & noise.

Heating Element: Dynamically balanced to eliminate vibration & noise. 2300 watt nichrome coil would element on state of the art convective cooling system. Ambient temp produced at nozzle is 70 degrees F.(21 C) Unit is protected by an integral thermal safety circuit breaker.

Timer: Fully enclosed, non-mechanical timer, that automatically turns off when hands are moved away from path of sensor.

Electric Eye: Sensor allows a hands free operation. When sensor beam path is disturbed, dryer will automatically turn on. When hands move away from beam, dryer stops.

Cover: Fabricated of #18 ga stainless steel, #4 satin finish, spot welded to form one piece unibody construction. Cover is secured to base with two tamper resistant fasteners. Special key provided to remove cover. All seams polished smooth.

Nozzle: Fixed chrome plated nozzle that can be changed from fixed to 2 position in the field.

Base: One piece #14 ga steel with 3/4" returns to wall surface for maximum strength and rigidity.

Unit	Volts	Amps	Cycles	Cover
U1521EA	120V	110-120	20 60	S/S
U1521EA	230V	220-230	10 60	S/S

Overall Size: 12 5/16"W x 8 1/2"H x 7"D
313mm x 216mm x 178mm

INSTALLATION

Coordinate installation with contractor, architect and licensed electrician. Transfer mounting points to wall surface with supplied templates. Check all code requirements for proper mounting heights. Secure base with proper fasteners for each application. Properly connect power supply to dryer. Test dryer for operation. Secure cover to base with supplied theft resistant fasteners(2). Test dryer again after cover is secured. Dryers have a full five (5) year warranty to original purchaser against defective materials and workmanship. Unit must be installed by a qualified licensed electrician.

Mounting	Hands	Hair
Men	46" (1168mm)	73" (1854mm)
Women	44" (1118mm)	68" (1727mm)
Physically Impaired	38" (965mm)	46" (1168mm)
Children 6-10	34" (864mm)	43" (1092mm)
Children 11-14	42" (1067mm)	56" (1422mm)

*Above are recommended mounting heights from lower mounting point above the finished floor.

NOTES

Formerly Model #: U1521EA

JOB #:

ITEM #:

QUANTITY:

MOUNTING	HANDING	TYPE	SIZE	OTHER
----------	---------	------	------	-------

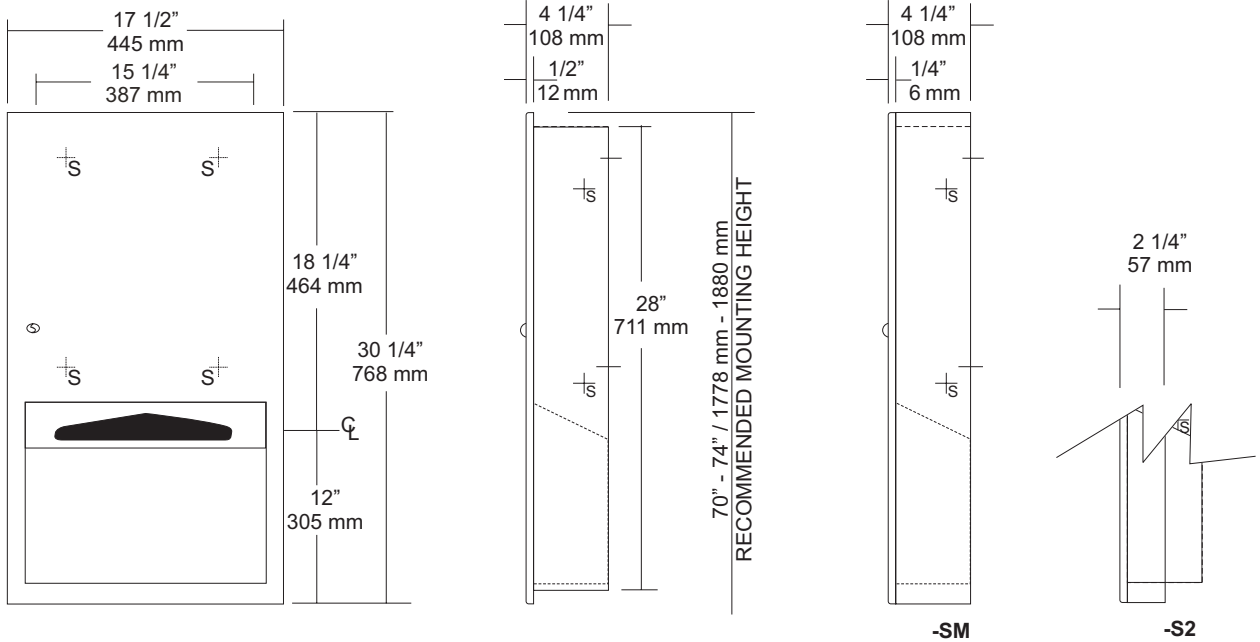

SPECIFICATIONS	INSTALLATION
----------------	--------------

Cabinet Body: Fabricated of #22 ga stainless steel. Face trim is an integral part of body with a #4 satin finish and 1/4" returns to wall surface for rigidity. One piece construction without miters or welds.

Uni-Door: Fabricated of #18 ga stainless steel with a #4 satin finish with 1/2" returns to wall surface.

Cabinet Back: Fabricated of #22 ga stainless steel with multiple welds to cabinet body:

Towel Dispensing: Hemmed edges that prevent injury and towel tearing.

Hinges: Heavy duty, full length, stainless steel piano type hinge secured door to cabinet.

Lock: Commercial quality, pin tumbler type lock keyed like all other AJW accessories.

Collars: Fabricated of #22 ga stainless steel finished to match cabinet for surface or recess mounting.

Overall Size: 17 1/2"W x 30 1/4"H x 4 1/4"D

445mm x 762mm x 108mm

Wall Opening: 15 3/4"W x 28 1/2"H x 4"D

400mm x 733mm x 102mm

U2314-S2: 2" semi-recessed collar, 2" wall opening 51mm.

U2314-SM: Full surface mounted collar.

Capacity: 600 c-fold or 800 multifold

Coordinate installation with architect and contractor to avoid interference with pipes vents etc. in wall. Provide a rough wall opening 15 3/4"W x 28 1/2"H. See specification for proper wall depth opening. Open cabinet and insert into wall opening. Secure with proper fasteners per each application. Fill unit with recommended towels, without overfilling. Make sure towels overlap each other so they will be available each time a towel is removed from dispensing area. Do not use abrasive or chloric solutions when cleaning cabinet.

NOTES

MOUNTING	HANDING	TYPE	SIZE	OTHER
----------	---------	------	------	-------

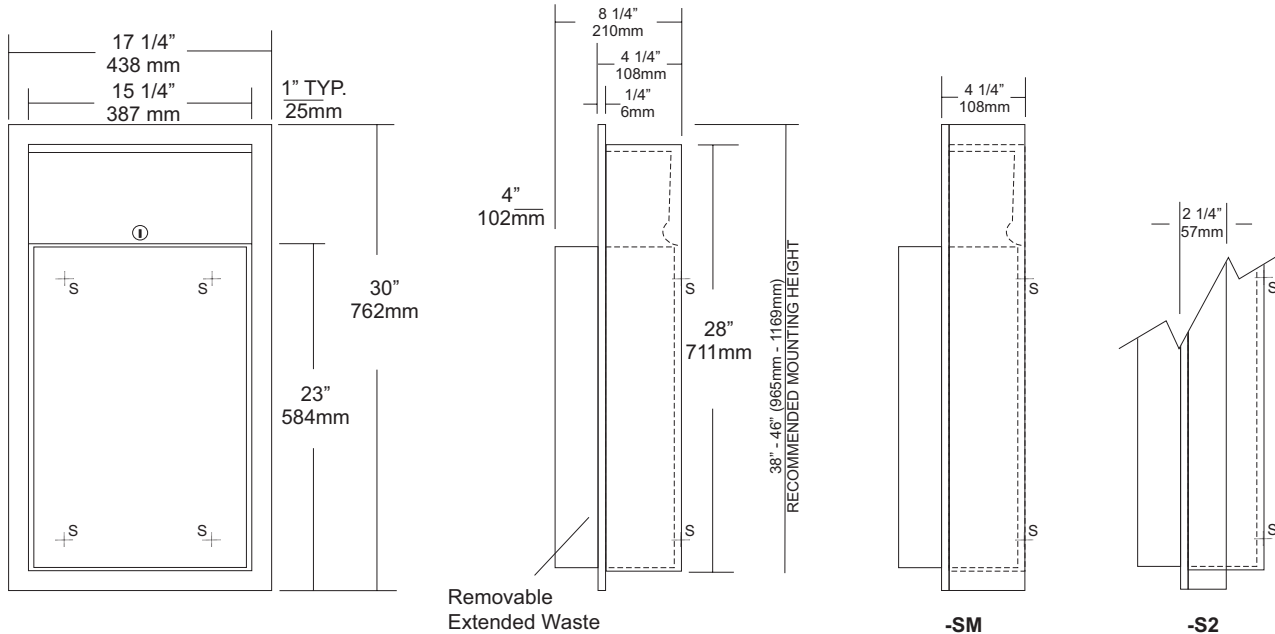

Removable
Extended Waste

-SM

-S2

SPECIFICATIONS

Body: Fabricated of #22 ga stainless steel with #4 satin finish on all exposed areas.

Flange: Fabricated of #22 ga stainless steel finished to match cabinet. One piece construction without miters or welds with 1/4" returns to wall surface for maximum strength.

Back: Fabricated of stainless steel formed for rigidity with multiple welds to cabinet body to form a one-piece construction.

Removable Waste: #22 ga stainless steel with #4 satin finish with hemmed edges and radius corners. Hook tabs allow liner to be installed are an integral part of waste can. Waste is secured in place by tumbler lock and bottom hanger. (12 gallon capacity)

Lock: Pin tumbler, commercial quality, keyed like all other AJW cabinets.

Collars: #22 ga stainless steel, sized & finished to match cabinet. (Used for surface mounting & semi-recessing)

Overall Size: 17 1/4"W x 30"H x 8 1/4"D (4" extended waste)
438mm x 762mm x 203mm

Wall Opening: 15 3/4"W x 28 1/2"H x 4"D
400mm x 724mm x 102mm

U410-S2: semi-recessed 2" collar(2" wall open.,51mm)

U410-SM: Surface mounting collar

Waste Capacity: 12 gallons (1.6 cu ft)

Options:

- VL1: Reusable vinyl liner
- CV: Covered Waste

INSTALLATION

Coordinate installation with architect and contractor. Provide a wall opening 15 3/4"W x 28 1/2"H . Wall depth will vary if collars are required. Remove waste from cabinet and insert into opening. Secure unit with proper fasteners for each application. Make sure each unit is plumb and true. Secure unit in cabinet by locking in place by tumbler lock. Liners may be installed. (VL1 Re-usable liner)

If semi-recessed cabinets are required see specification for wall depth's.

NOTES



U580
 Partition Mounted Sanitary Napkin
 Disposal
 Revision 09/13

JOB #:
 ITEM #:
 QUANTITY:

MOUNTING	HANDING	TYPE	SIZE	OTHER
----------	---------	------	------	-------

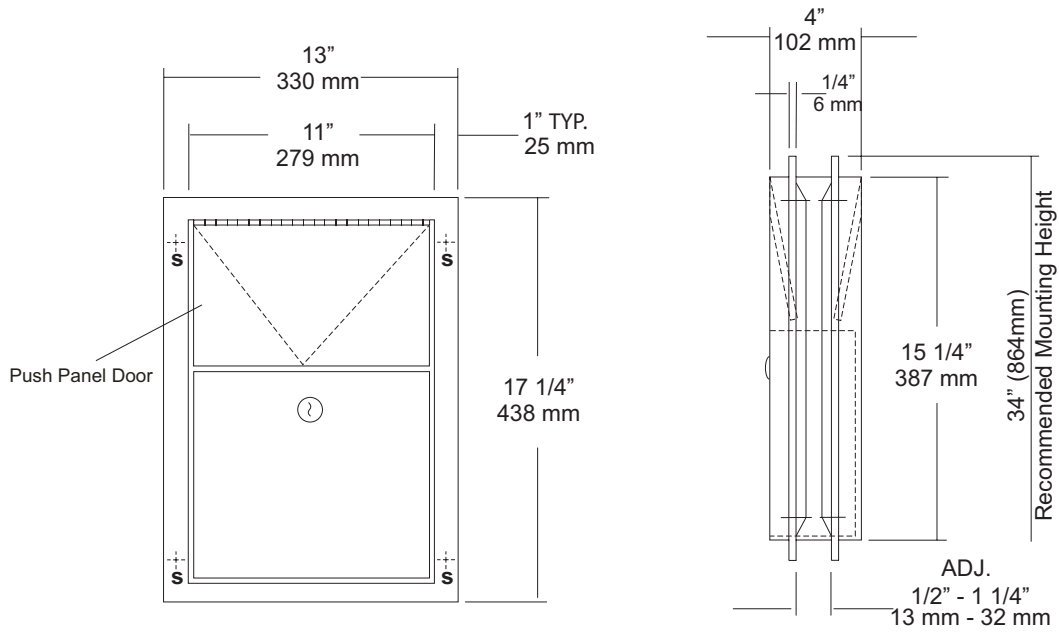

SPECIFICATIONS

Body: Fabricated of #22 ga stainless steel, #4 satin finish.
Flanges: Fabricated of #22 ga stainless steel, drawn one-piece construction with 1/4" returns to wall surface. One flange is welded to body the other is adjustable to fit 1/2" - 1 1/4" thick partitions. (No miters or welds).
Push Panels: Fabricated of #22 ga stainless steel self closing push panel door. *International graphic symbol optional*
Waste: #22 ga stainless steel removable from one side with pin tumbler type lock securing in place. Optional finger grip in lieu of lock
Locks: Pin tumbler locks keyed like all other AJW cabinets.
Hinges: Full length, heavy duty, stainless steel piano type.
Overall Size: 13"W x 17 1/4"H x 4"D
330mm x 438mm x 108mm
Wall Opening: 11 1/2"W x 15 3/4"H
292mm x 400mm
Capacity: 1.5 gallons (.2 cu ft)
NDL-13-50: Waxed disposable liners. (50 per Case)
U580-PW: Same as U580 with plastic removable waste.

INSTALLATION

Provide a rough partition opening 11 1/2"W x 15 3/4"H. Remove adjustable flange and place unit into opening. Secure welded flange to partition at four points making sure unit fits flush and is level. Place adjustable flange over unit and secure to partition the same way as the fixed flange. Be sure the proper fasteners are used for each application.

NOTES

JOB #:

ITEM #:

QUANTITY:

MOUNTING	HANDING	TYPE	SIZE	OTHER

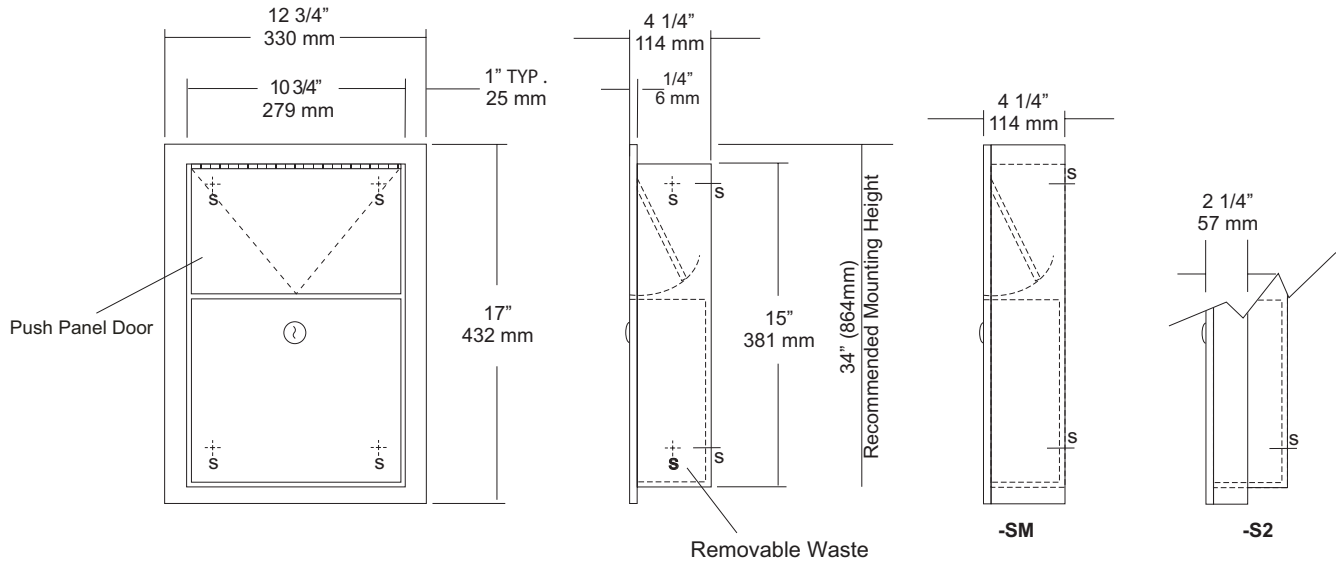

SPECIFICATIONS

Body: Fabricated of #22 ga stainless steel, #4 satin finish.
Flange: Fabricated of #22 ga stainless steel #4 satin finish, drawn one piece construction with 1/4" returns to wall surface. (Without miters or welds)
Push Panel: #22 ga stainless steel self closing push panel door.
 *International Graphic Symbols are optional.
Waste: #22 ga stainless steel, removable type waste, secured by pin tumbler lock. Pin tumbler commercial quality locks, keyed like all other AJW cabinets. *(Optional finger grip in lieu of lock)
Hinges: Full length, heavy duty, stainless steel hinge.
Collars: #22 ga stainless steel finished and sized to match cabinet.
Overall Size: 12 3/4"W x 17"H x 4 1/4"D
330mm x 432mm x 108mm
Wall Opening: 11 1/4"W x 15 1/2"H x 4"D
292mm x 394mm x 108mm
Capacity: 1.5 gallons (.2 cu ft)
U581-S2: semi-recessed Disposal
Wall Opening: 11 1/4"W x 15 1/2"H x 2"D
292mm x 394mm x 51mm
NDL-13-50: Waxed disposable liners(50 per Case)
C12174 : Collar will convert recessed to surf mounted.
U581-PW: Same as U581 with plastic removable waste.

INSTALLATION

Coordinate installation with architect or contractor to avoid interference with pipes, vents, etc. Provide a rough wall opening 11 1/2"W x 15 1/2"H. Verify depth for either the recessed or semi-recessed model. Remove waste from cabinet and secure in opening with proper fasteners for each application making sure unit is level.

NOTES

U705 Series Angle Frame Mirror & Shelf

Revision 11/15

JOB #:

ITEM #:

QUANTITY:

MOUNTING	HANDING	TYPE	SIZE	OTHER

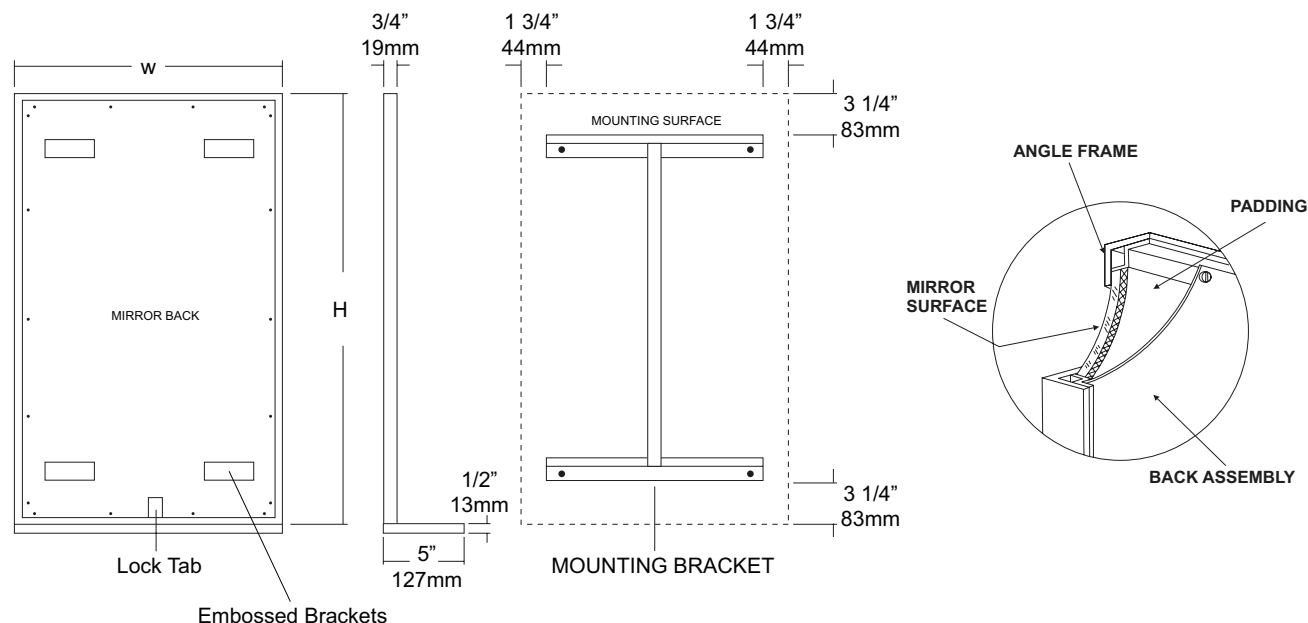

SPECIFICATIONS

Frame: Fabricated of #18 ga stainless steel, #4 satin finish. 3/4" x 3/4" frame with welded mitered corners are ground and polished smooth. #22 ga concealed "Z" channel is spot welded to frame for greater rigidity.

Mirror: 1/4" thick type 1 transparent flat type, class 1 - clear glass mirrors. Mirror is coated with silver and sealed with a uniform electrolytic copper plating, along with two coats of paint for added protection. Mirrors are guaranteed against silver spoilage for a period of 15 years. Mirrors conform to ASTM C1036 and ASTM C1503-R8.

Shelf: #18 ga stainless steel with #4 satin finish. Shelf is 5"D x full width of mirror. All edges are turned down 1/2" with front edge turned back 1/2" for rigidity and prevents possible injury. #18 ga support bracket is welded to both frame and shelf then ground smooth.

Filler: 3/16" thick full size, shock absorbing, water resistant, non-abrasive polyethylene padding protects all concealed mirror surfaces.

Back: #20 ga pre-plated galvanized steel, with embossed horizontal louver mounting brackets. Embossed theft resistant pressure activated clip lock device, locks mirror in place to wall hangers.

Hangers: Fabricated of #20 ga pre-plated galv. steel.

Standard Sizes Available (W x H): 16"x24", 16"x30", 18"x24", 18"x30", 18"x36", 24"x30", 24"x36"

Options:

LG: Laminated Glass

LX: Polycarbonate

PM: Plastic Acrylic

T: Tempered Glass

VC: Vinyl Clad (Safety Glass)

8B: #8 Reflective Stainless Steel

*Stainless steel mirrors reflect images in different optic quality than plate glass. There will be a slight distortion which increases proportionately with the mirror size. Therefore, AJW Architectural Products™ cannot be held responsible for quality of image.

**Mirrors are always ordered Width x Height

***Recommended max size for 8B mirrors: 72" x 47'-1/2"

****Framed mirrors are fabricated to a tolerance of (+/-) 1/8"

***** Mirrors conform to Federal Specifications DD-M-00411b & DD-g-541D

INSTALLATION

Coordinate installation with architect / contractor for specific mounting location and height for each mirror application. Making sure "I" bracket is level, transfer all mounting point locations to wall surface from drawing. Secure brackets with proper fasteners for each application. Slide mirror down over horizontal brackets until clip lock secures mirror in place. Mirror can only be removed by inserting tool through hole at bottom of frame depressing clip. This will allow mirror to slide up over brackets. Fillers are available if mirrors are mounted above and below tile line. (U004 Filler) filler material will match mirror frame to form a one piece construction.

To meet ADA Code, bottom edge of reflective surface can be no higher than 40" above finished floor. (4.19.6) Full length mirrors may be used for universal application when installed in correct locations.

Abrasive cleaners & chloric solutions should not be used on mirrors. Discoloring and /or scratching of frame and reflective surface may occur.

NOTES



U840 Toilet Tissue Dispenser

Revision 03/11

JOB #:

ITEM #:

QUANTITY:

MOUNTING	HANDING	TYPE	SIZE	OTHER

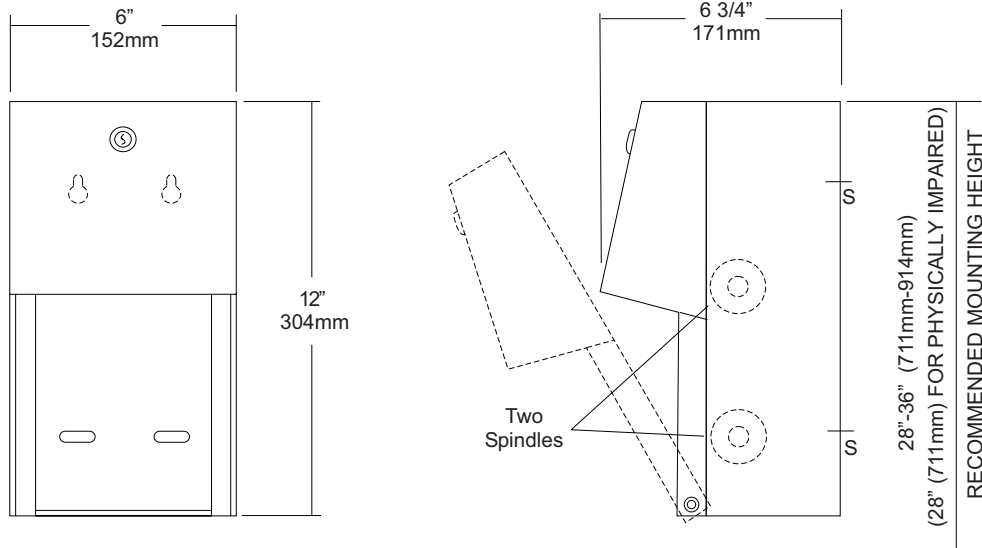

SPECIFICATIONS

Body: Fabricated of #22 ga stainless steel with #4 satin finish. Concealed inner dispensing mechanism is #18 ga stainless steel.

Back: Fabricated of #18 ga stainless steel with multiple welds to cabinet body forming a one piece construction.

Hood: Fabricated of #18 ga stainless steel finished to match cabinet body. Hood is secured with stainless steel hinge rivets to cabinet body. Top roll of tissue will not drop down unless the bottom roll has been depleted. When unit is closed, this will provide a theft resistant, non-control operation and reduce vandalism.

Locks: Pin tumbler, commercial quality locks keyed like all other AJW cabinets.

Spindles: (U005) Fabricated of one-piece molded high impact black ABS material.

Overall Size: 6"W x 12"H x 6 3/4"D

152mm x 305mm x 171mm

Capacity: Two standard rolls with a 5 1/4" (133mm) OD..

INSTALLATION

Provide an area on mounting surface at desired or specified location. Open cabinet, remove spindles and hold unit to wall at desired location. Transfer mounting points and drill pilot holes. Secure unit with proper fasteners per each application. Load toilet tissue on rollers, place in concealed track and close hood. Raise lower roll against upper and take hand away. Lower roll should fall into place with upper roll remaining up above the hood line. If loaded properly, top roll will not fall for use until bottom roll has been depleted. When servicing dispenser, full rolls must be used on both spindles to insure proper operation.

All toilet tissue dispensers that meet ADA code cannot have any type of control delivery. (4.16)

NOTES

Formerly Model #: U840A

JOB #:

ITEM #:

QUANTITY:

MOUNTING	HANDING	TYPE	SIZE	OTHER

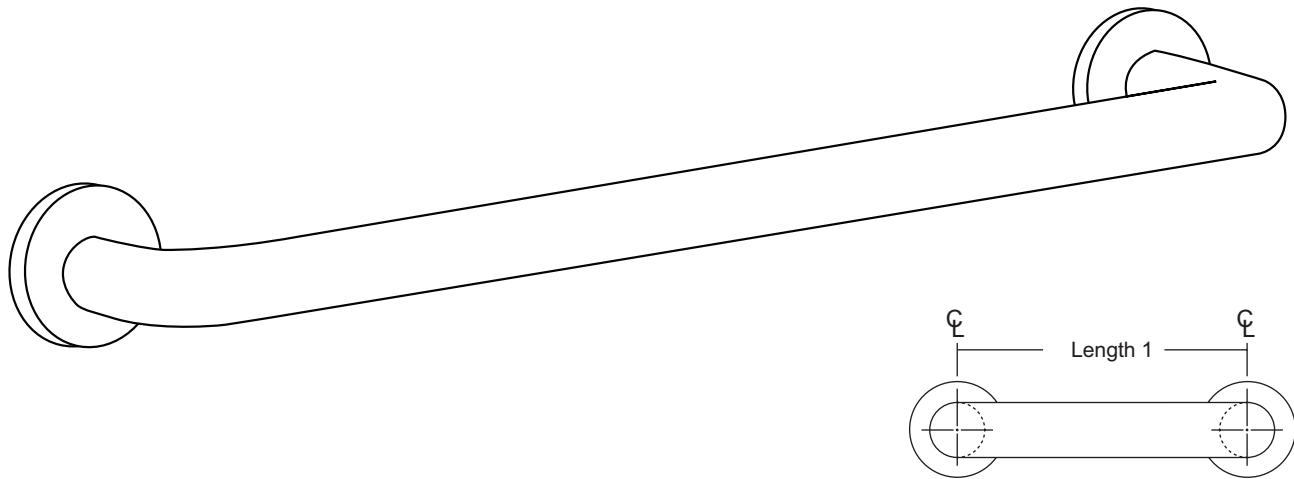

SPECIFICATIONS & INSTALLATION

Tubing: Fabricated of #18 ga stainless steel with a #4 satin finish. Available in 1 1/4" outside diameter. All bends are formed by an automatic mandrel bending process. All bars maintain a constant 1 1/2" offset.

Finish: Standard finish is a #4 satin finish. For a non-slip finish (peened) add suffix X to model number. (Ex. UG120X-A)

Flange: Fabricated of 3" diameter, #11 ga stainless steel with #4 satin finish to match tubing. Flanges are heliarc welded to bar to form a one piece construction. Each flange has three (3) mounting points (1/4" dia.)

Strength: Bars with a 1 1/2" offset clearance will support loads in excess of 900lbs when properly installed. Bars with greater offsets will support loads up to 250lbs when properly installed.

Installation: Before installing grab bars, verify with all state and local codes for requirements on bar diameter and type finish. Recommended mounting heights for grab bars are 33" - 36" centerline above finished floor. All mounting of grab bars when possible should have in wall mounting back plates. Find centerline mounting points and place bar on line making sure to be on center. Transfer mounting points (3 per flange) to wall. Drill pilot holes and secure bar with proper anchors per application.

Standard Lengths (Other sizes available upon request): 12", 16", 18", 24", 30", 32", 36", 42", 48", 50", 52", 54", 56"

FLANGE INFORMATION

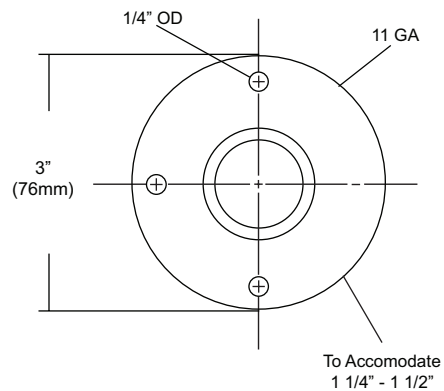
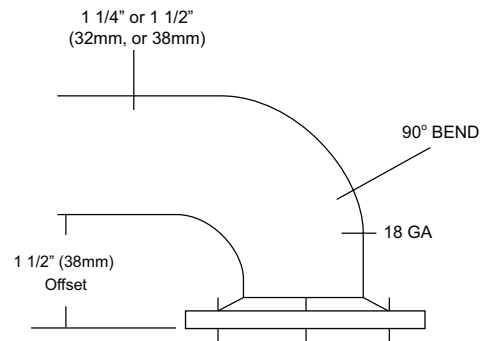

NOTES



UJ45 Series

Mop Holder & Hook Strip Combination Unit

Revision 03/11

JOB #:

ITEM #:

QUANTITY:

MOUNTING	HANDING	TYPE	SIZE	OTHER

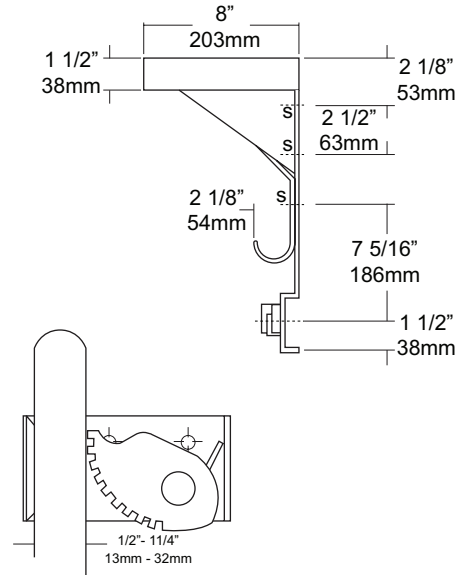
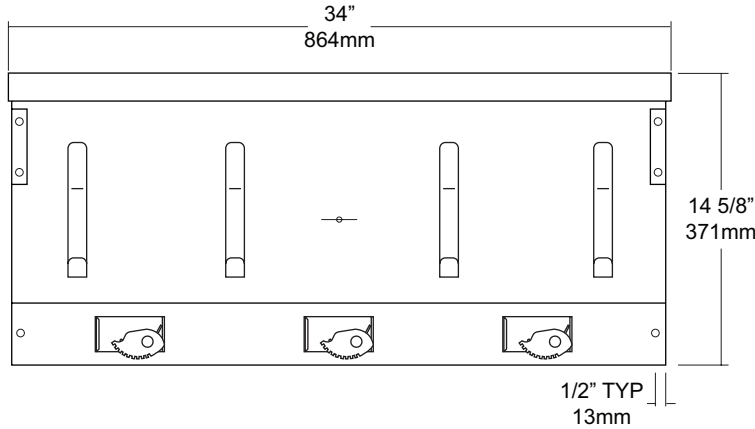

SPECIFICATIONS

Shelf: Fabricated of #18 ga stainless steel with a #4 satin finish, 8" deep (203mm) bent down 1 1/2" with 1/2" returns back for rigidity and safety.

Back: Fabricated of #18 ga stainless steel, #4 satin finish. Lower portion has a formed channel for added rigidity to support the mop holders.

Mop Holders: UJ19 plated reinforced steel with serrated cam type hard rubber mop or broom holder. Holds handles 1/2" to 1 1/4" diameter.

Hooks: #14 ga stainless steel with a #4 satin finish.

Mounting Brackets: #16 ga stainless steel with exposed mounting points.

Verify Style:

UJ45A: 34"L (864mm) with 3 holders, 4 hooks.

UJ45B: 44"L (1118mm) with 4 holders, 5 hooks.

UJ45C: 54"L (1372mm) with 5 holders, 6 hooks.

INSTALLATION

Place unit to wall surface making sure unit is level and transfer mounting points. Drill pilot holes and secure unit with proper fasteners per application.

NOTES