

date  
projectname  
attn  
from  
fax  
email  
phone

6/28/16  
WOHS  
R.T.



# U124 Soap Dispenser

Revision 11/14

JOB #:

ITEM #:

QUANTITY:

MOUNTING	HANDING	TYPE	SIZE	OTHER



### SPECIFICATIONS

**Soap Tank:** Fabricated of #20 ga stainless steel, #4 satin finish, fully welded one-piece construction.

**Valve:** All purpose antibacterial soap valve cylinder, black molded plastic push style valve that takes less than 5 lbs of force and one hand to operate complies with barrier free guidelines when mounted at proper height.

**Viewer:** Clear plastic window allows a constant fluid level check.

**Concealed Mounting Plate:** Fabricated of heavy gauge stainless steel.

**Filler Cap:** Fabricated of stainless steel, hinged to allow easy servicing, secured with special key that creates a vandal resistant dispenser.

**Overall Size:** 8 1/4"W x 4 3/4"H x 3 3/4"D  
**210mm x 121mm x 95mm (Horizontal Mounting)**

**Capacity:** 40 oz.

**Recommend type soaps without chloric solutions for proper operation.**

### INSTALLATION

Provide an area on mounting surface at desired or specified location. Secure concealed mounting plate to wall surface with proper fasteners. Slide dispenser down over mounting plate and secure by means of set screw located inside tank. Fill unit with proper soap. Close lid and secure with special key. Test valve for proper operation.

\*It is not recommended to mount any soap dispenser on mirrors

\*\*For best performance, use pre-mixed low concentrate solutions. Dispensers should have periodic maintenance performed to insure the life dispenser. Rinse out globe and valve with warm water to avoid sludge buildup.

Preventative Maintenance: Each dispenser should be flushed out aprx. Every 30 days with warm water to prevent valve from; clogging with old soap. Abrasive cleaners should not be used when wiping down dispenser.

### NOTES



# U180

Folded Towel Dispenser

Revision 03/11

JOB #:

ITEM #:

QUANTITY:

MOUNTING	HANDING	TYPE	SIZE	OTHER



### SPECIFICATIONS

**Cabinet:** #22 ga. stainless steel with #4 satin finish. Striker tabs prevents damage to mounting surface when cover is closed. (Unibody design)

**Cabinet Back:** #22 ga stainless steel with embossed towel guides.

**Hinges:** Full length, heavy duty, stainless steel , piano type hinge. (Welded, no rivets)

**Locks:** Pin tumbler, commercial quality, keyed like all other AJW cabinets.

**Towel Dispenser:** Area is hemmed to prevent towel tearing and injury.

**Overall Size:** 11"W x 14 1/2"H x 4"D (stainless steel)  
**279mm x 368mm x 102mm**

**Capacity:** 400 c-fold or 525 multifold

**Options:**

- TK: Twist lock in lieu of keyed lock.

### INSTALLATION

Provide an area on mounting surface at desired or specified location. Open cover and place unit against wall and transfer mounting points after checks out to be level and is at the proper mounting height. Secure unit to surface with proper fasteners, fill cabinet with towels, close cover and remove key.

Recommend towel dispensing area at a height of 40" above finished floor to meet ADA Code.

### NOTES

JOB #:

ITEM #:

QUANTITY:

MOUNTING	HANDING	TYPE	SIZE	OTHER
----------	---------	------	------	-------

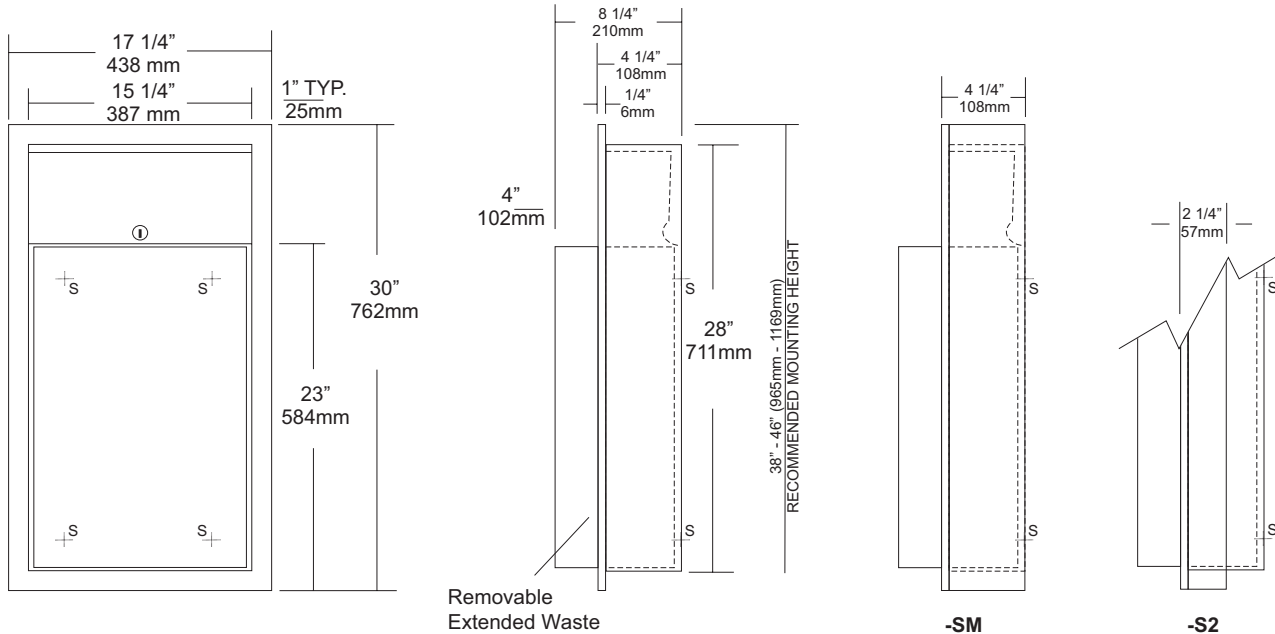

Removable  
Extended Waste

-SM

-S2

### SPECIFICATIONS

**Body:** Fabricated of #22 ga stainless steel with #4 satin finish on all exposed areas.

**Flange:** Fabricated of #22 ga stainless steel finished to match cabinet. One piece construction without miters or welds with 1/4" returns to wall surface for maximum strength.

**Back:** Fabricated of stainless steel formed for rigidity with multiple welds to cabinet body to form a one-piece construction.

**Removable Waste:** #22 ga stainless steel with #4 satin finish with hemmed edges and radius corners. Hook tabs allow liner to be installed are an integral part of waste can. Waste is secured in place by tumbler lock and bottom hanger. (12 gallon capacity)

**Lock:** Pin tumbler, commercial quality, keyed like all other AJW cabinets.

**Collars:** #22 ga stainless steel, sized & finished to match cabinet. (Used for surface mounting & semi-recessing)

**Overall Size:** 17 1/4"W x 30"H x 8 1/4"D (4" extended waste)  
**438mm x 762mm x 203mm**

**Wall Opening:** 15 3/4"W x 28 1/2"H x 4"D  
**400mm x 724mm x 102mm**

**U410-S2:** semi-recessed 2" collar(2" wall open.,51mm)

**U410-SM:** Surface mounting collar

**Waste Capacity:** 12 gallons (1.6 cu ft)

**Options:**

- VL1: Reusable vinyl liner
- CV: Covered Waste

### INSTALLATION

Coordinate installation with architect and contractor. Provide a wall opening 15 3/4"W x 28 1/2"H . Wall depth will vary if collars are required. Remove waste from cabinet and insert into opening. Secure unit with proper fasteners for each application. Make sure each unit is plumb and true. Secure unit in cabinet by locking in place by tumbler lock. Liners may be installed. (VL1 Re-usable liner)

If semi-recessed cabinets are required see specification for wall depth's.

### NOTES



**U590**  
 Sanitary Napkin Disposal with Access  
 Panel  
 Revision 10/11

JOB #:
ITEM #:
QUANTITY:

MOUNTING	HANDING	TYPE	SIZE	OTHER

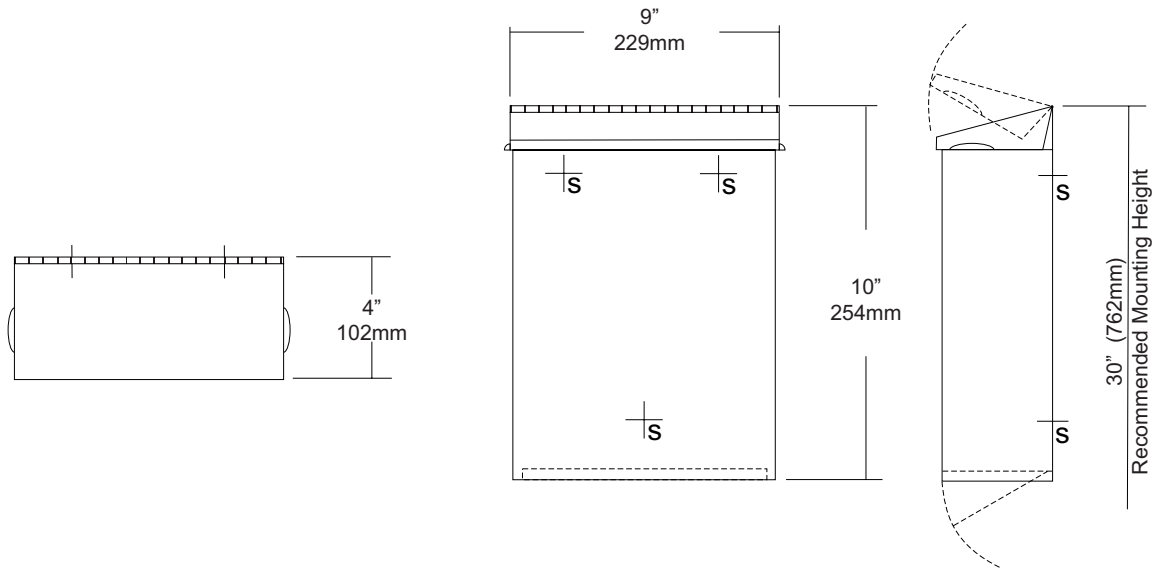

**SPECIFICATIONS**

**Cabinet Body:** Fabricated of #22 ga stainless steel with #4 satin finish. Seamless construction with radius and hemmed edges.  
**Cabinet Back:** Fabricated of Stainless steel welded to cabinet body with key hole mounting points.  
**Cover:** Fabricated of #22 ga stainless steel #4 satin finish with embossed handles on each side and sloped top.  
**Bottom Panel:** #22 ga hinged and locked for removal of contents.  
**Hinges:** Heavy duty, full length, stainless steel piano type hinges.  
**Lock:** Commercial quality keyed like all other AJW cabinets.  
**Overall Size:** 9"W x 10"H x 4"D  
**229mm x 254mm x 102mm**  
**Capacity:** 1.6 gallons (.2 cu ft)  
**NDL-13-50:** Waxed disposable liners. (50 per Case)

**INSTALLATION**

Provide an area at desired or specified location. Place unit on surface and transfer mounting points. Drill pilot holes and secure with proper fasteners. Install waxed liner.

**NOTES**

MOUNTING	HANDING	TYPE	SIZE	OTHER
----------	---------	------	------	-------

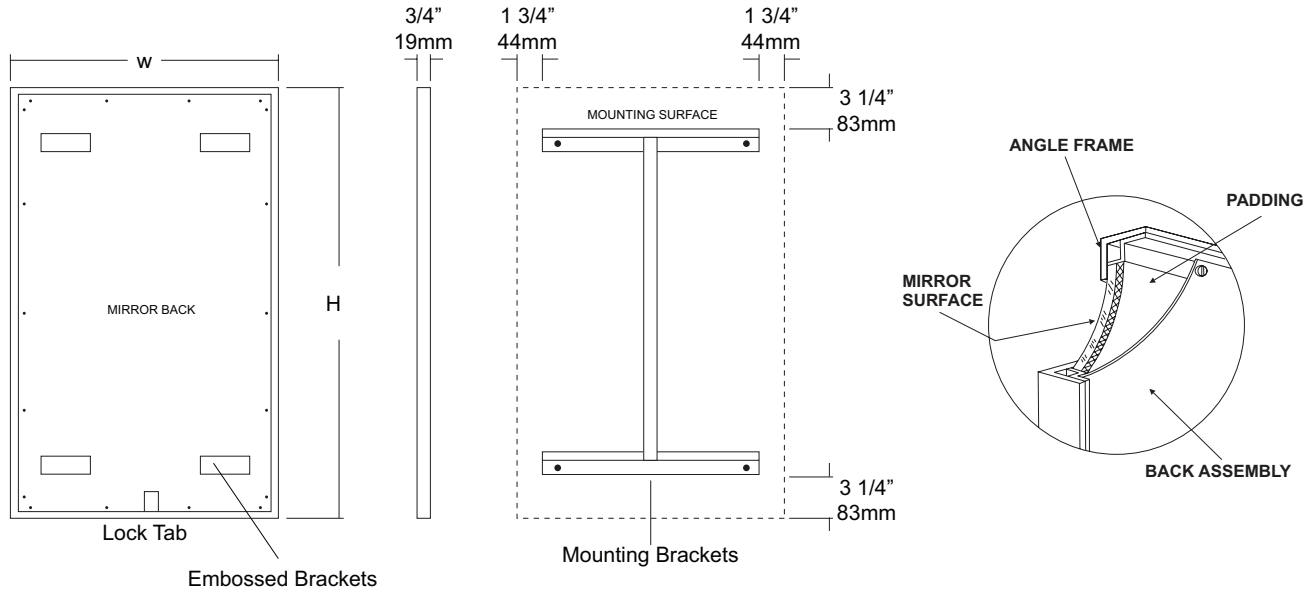

#### SPECIFICATIONS

**Frame:** Fabricated of #18 ga stainless steel, #4 satin finish. 3/4" x 3/4" frame with welded mitered corners are ground and polished smooth. #22 ga concealed "Z" channel is spot welded to inner perimeter of frame for reinforcement and greater rigidity.

**Mirror:** 1/4" thick type 1 transparent flat type, class 1 - clear glass mirrors. Mirror is coated with silver and sealed with a uniform electrolytic copper plating, along with two coats of paint for added protection. Mirrors are guaranteed against silver spoilage for a period of 15 years. Mirrors conform to ASTM C1036 and ASTM C1503-R8.

**Filler:** 3/16" thick full size, shock absorbing, water resistant, non-abrasive polyethylene padding protects all concealed mirror surfaces.

**Back:** #20 ga pre-plated galvanized steel, with embossed horizontal louver mounting brackets. Embossed theft resistant pressure activated clip lock device, locks mirror in place to wall hangers. Back is secured to frame with concealed Phillips head screws.

**Hangers:** Fabricated of #20 ga pre-plated steel galvanized steel with mounting points.

**Standard Sizes Available (W x H):** 16"x24", 16"x20", 16"x30", 18"x24", 18"x30", 18"x36", 20"x60", 24"x30", 24"x36", 24"x42", 24"x48", 18"x60", 24"x60", 24"x72", 18"x72"

#### Options:

- LG:** Laminated Glass
- LX:** Polycarbonate
- PM:** Plastic Acrylic
- T:** Tempered Glass
- VC:** Vinyl Clad (Safety Glass)
- 8B:** #8 Reflective Stainless Steel

\* Stainless steel mirrors reflect images in different optic quality than plate glass. There will be a slight distortion which increases proportionately with the mirror size. Therefore, AJW Architectural Products™ cannot be held responsible for quality of image.

\*\* Mirrors are always ordered Width x Height

\*\*\* Recommended max size for 8B mirrors: 72" x 47-1/2"

\*\*\*\* Framed mirrors are fabricated to a tolerance of (+/-) 1/8"

\*\*\*\*\* Mirrors conform to Federal Specifications DD-M-00411b & DDg-541D.

#### INSTALLATION

Coordinate installation with architect / contractor for specific mounting location and height for each mirror application. Making sure "I" bracket is level, transfer all mounting point locations to wall surface from drawing. Secure brackets with proper fasteners for each application. Slide mirror down over horizontal brackets until clip lock secures mirror in place. Mirror can only be removed by inserting tool through hole at bottom of frame depressing clip. This will allow mirror to slide up over brackets. Fillers are available if mirrors are mounted above and below tile line. (U004 Filler) filler material will match mirror frame to form a one piece construction.

To meet ADA Code, bottom edge of reflective surface can be no higher than 40" above finished floor. (4.19.6) Full length mirrors may be used for universal application when installed in correct locations.

Abrasive cleaners & chloric solutions should not be used on mirrors. Discoloring and /or scratching of frame and reflective surface may occur.

#### NOTES



# U704 Series

## Fixed Tilt Angle Frame Mirror

Revision 11/15

JOB #:

ITEM #:

QUANTITY:

MOUNTING	HANDING	TYPE	SIZE	OTHER

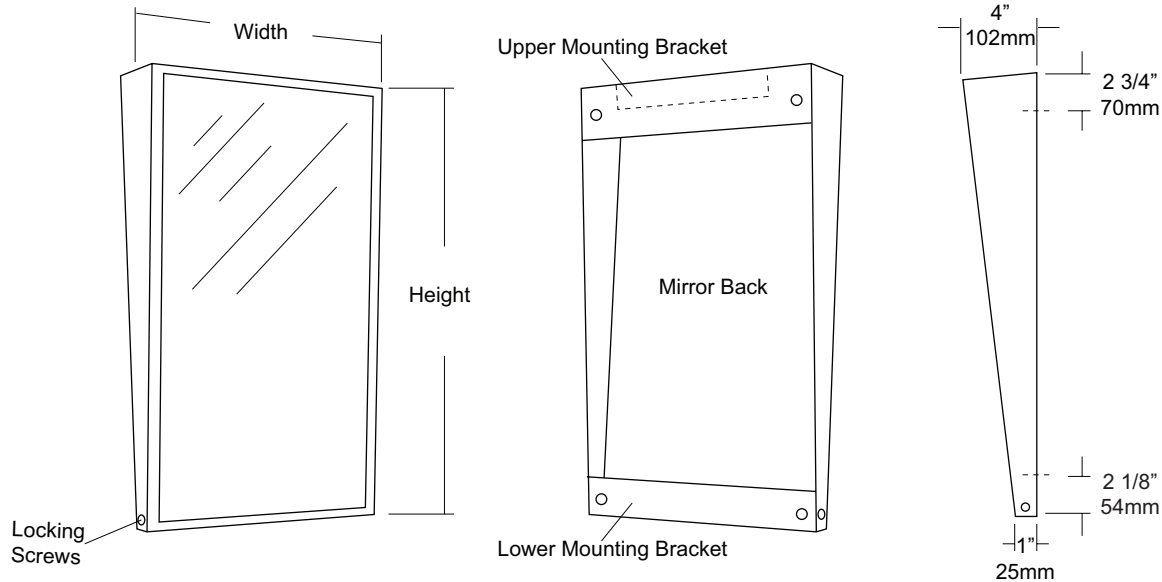

### SPECIFICATIONS

**Frame:** Fabricated of #18 ga stainless steel, #4 satin finish. Stainless steel frame is fabricated with welded mitered corners that are ground and polished smooth. Mirror extends out 4" at top and tapers to 1" at bottom.

**Mirror:** 1/4" thick type 1 transparent flat type, class 1 - clear glass mirrors. Mirror is coated with silver and sealed with a uniform electrolytic copper plating, along with two coats of paint for added protection. Mirrors are guaranteed against silver spoilage for a period of 15 years. Mirrors conform to ASTM C1036 and ASTM C1503-R8.

**Filler:** 3/16" thick full size, shock absorbing, water resistant, non-abrasive polyethylene padding protects all concealed mirror surfaces

**Brackets:** Mounting brackets are fabricated of #20 ga pre-plated, galvanized steel. Lower bracket has two (2) side mounting points that allow frame to be secured to bracket.

**Standard Sizes Available (W x H):** 16"x24", 16"x30", 18"x24", 18"x30", 18"x36", 24"x30", 24"x36"

**Options:**

**LG:** Laminated Glass

**LX:** Polycarbonate

**PM:** Plastic Acrylic

**T:** Tempered Glass

**VC:** Vinyl Clad (Safety Glass)

**8B:** #8 Reflective Stainless Steel

\*Stainless steel mirrors reflect images in different optic quality than plate glass. There will be a slight distortion which increases proportionately with the mirror size. Therefore, AJW Architectural Products™ cannot be held responsible for quality of image.

\*\* Mirrors are always ordered Width x Height

\*\*\* Recommended max size for 8B mirrors: 72" x 47-1/2"

\*\*\*\* Framed mirrors are fabricated to a tolerance of (+/-) 1/8"

\*\*\*\*\* Mirrors conform to Federal Specifications DD-M-00411b & DD-g-541D

### INSTALLATION

Coordinate installation with architect / contractor for specific mounting location and height for each mirror application. Check all state and local codes for installation requirements. Remove hanger brackets and transfer mounting points to wall surface. Secure with proper fasteners for each application. Slide mirror frame over brackets and secure in place. Secure frame to bracket. Fillers are available if mirrors are mounted above and below tile line. (U004 Filler) Filler material will match mirror frame to form a one piece construction.

To meet ADA Code, bottom edge of reflective surface can be no higher than 40" above finished floor. (4.19.6) Full length mirrors may be used for universal application when installed in correct locations.

Abrasive cleaners & chloric solutions should not be used on mirrors. Discoloring or scratching may occur on frame and reflective surface.

### NOTES



# U806

Toilet Tissue Dispenser

Revision 03/11

JOB #:

ITEM #:

QUANTITY:

MOUNTING	HANDING	TYPE	SIZE	OTHER

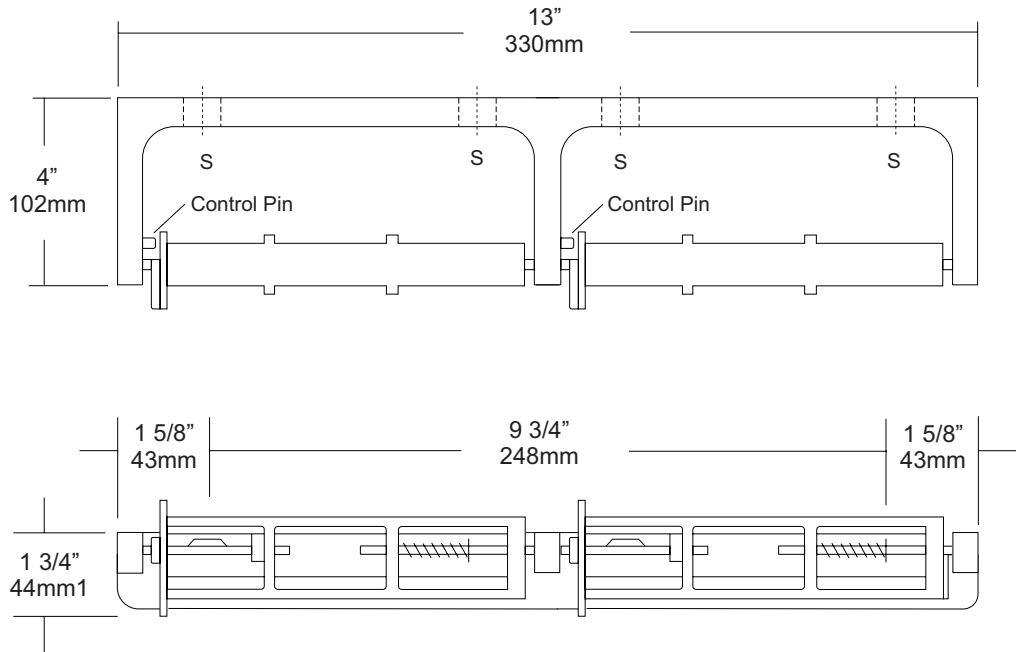

SPECIFICATIONS	INSTALLATION
----------------	--------------

**Mounting Bracket:** Fabricated of heavy duty, die cast aluminum alloy, satin matte finish. One piece formed construction provides maximum strength and rigidity.

**Spindles:** Molded high impact ABS material (theft resistant) with stainless steel spring, designed to retain spindles on bracket. Spring loaded pin prevents roll from being removed until roll is depleted. Spindle rotates only 1/2 revolution.

**Control Pin:** Stainless steel pin provides dispenser a control delivery. On the -NC units (non-control) the pin is removed. This can be removed at the factory or in the field.

**Overall Size:** 13"W x 1 3/4"H x 4"D  
**330mm x 45mm x 102mm**

**Capacity:** Two standard rolls with a 5 1/4" (133mm) OD.

**U806-NC:** Same as U806 with non-controlled delivery to comply with ADA code

Provide an area on wall surface at desired or specified location. Place unit on mounting surface making sure unit is level and transfer mount points. Drill pilot holes and secure with proper fasteners per application. If a controlled delivery dispenser is installed, remove spring loaded pin to obtain a non-controlled delivery. All dispensers must have a non-control delivery, be mounted at the proper height and location to meet ADA code. (4.16)

**NOTES**





# UG120-A

Grab Bars

Revised 03/11

JOB #:

ITEM #:

QUANTITY:

MOUNTING	HANDING	TYPE	SIZE	OTHER



### SPECIFICATIONS & INSTALLATION

**Tubing:** Fabricated of #18 ga stainless steel with a #4 satin finish. Available in 1 1/4" outside diameter. All bends are formed by an automatic mandrel bending process. All bars maintain a constant 1 1/2" offset.

**Finish:** Standard finish is a #4 satin finish. For a non-slip finish (peened) add suffix X to model number. (Ex. UG120X-A)

**Flange:** Fabricated of 3" diameter, #11 ga stainless steel with #4 satin finish to match tubing. Flanges are heliarc welded to bar to form a one piece construction. Each flange has three (3) mounting points (1/4" dia.)

**Strength:** Bars with a 1 1/2" offset clearance will support loads in excess of 900lbs when properly installed. Bars with greater offsets will support loads up to 250lbs when properly installed.

**Installation:** Before installing grab bars, verify with all state and local codes for requirements on bar diameter and type finish. Recommended mounting heights for grab bars are 33" - 36" centerline above finished floor. All mounting of grab bars when possible should have in wall mounting back plates. Find centerline mounting points and place bar on line making sure to be on center. Transfer mounting points (3 per flange) to wall. Drill pilot holes and secure bar with proper anchors per application.

**Standard Lengths (Other sizes available upon request):** 12", 16", 18", 24", 30", 32", 36", 42", 48", 50", 52", 54", 56"

### FLANGE INFORMATION

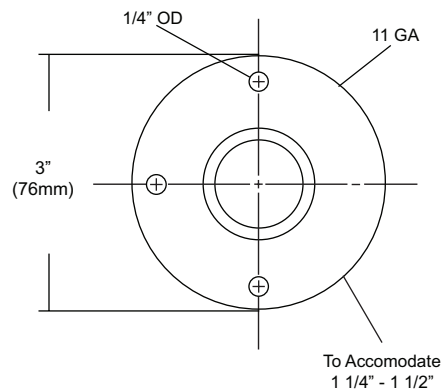
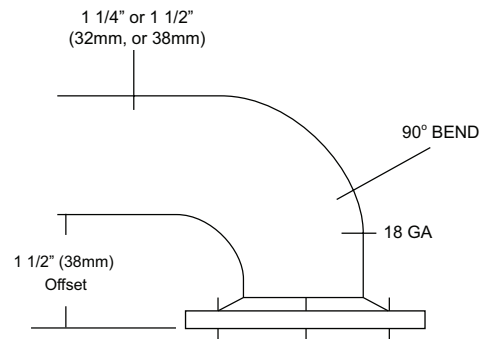

### NOTES



# UG120-G

Grab Bars

Revised 03/11

JOB #:

ITEM #:

QUANTITY:

MOUNTING	HANDING	TYPE	SIZE	OTHER

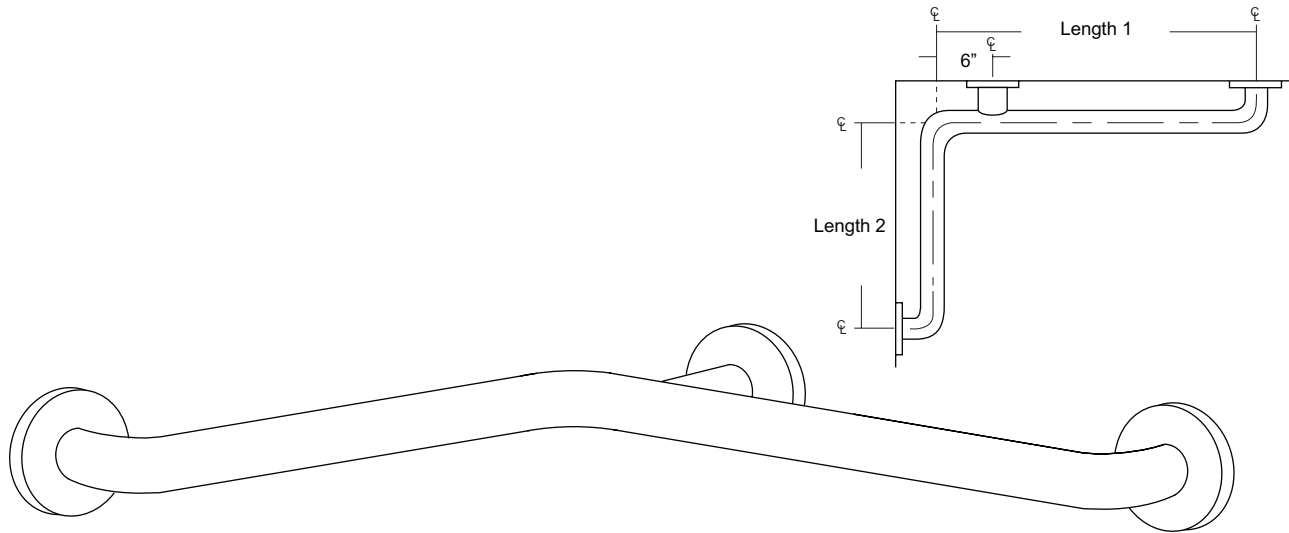

### SPECIFICATIONS & INSTALLATION

**Tubing:** Fabricated of #18 ga stainless steel with a #4 satin finish. Available in 1 1/4" outside diameter. All bends are formed by an automatic mandrel bending process. All bars maintain a constant 1 1/2" offset.

**Finish:** Standard finish is a #4 satin finish. For a non-slip finish (peened) add suffix X to model number. (Ex. UG120X-G)

**Flange:** Fabricated of 3" diameter, #11 ga stainless steel with #4 satin finish to match tubing. Flanges are heliarc welded to bar to form a one piece construction. Each flange has three (3) mounting points (1/4" dia.)

**Strength:** Bars with a 1 1/2" offset clearance will support loads in excess of 900lbs when properly installed. Bars with greater offsets will support loads up to 250lbs when properly installed.

**Installation:** Before installing grab bars, verify with all state and local codes for requirements on bar diameter and type finish. Recommended mounting heights for grab bars are 33" - 36" centerline above finished floor. All mounting of grab bars when possible should have in wall mounting back plates. Find centerline mounting points and place bar on line making sure to be on center. Transfer mounting points (3 per flange) to wall. Drill pilot holes and secure bar with proper anchors per application.

**Standard Lengths (Other sizes available upon request):** 30" x 16", 30" x 18", 36" x 18", 36" x 24", 42" x 36", 54" x 36"

### FLANGE INFORMATION

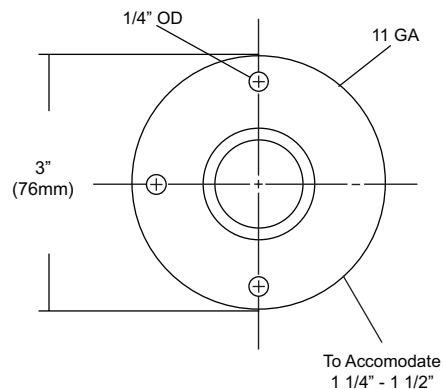
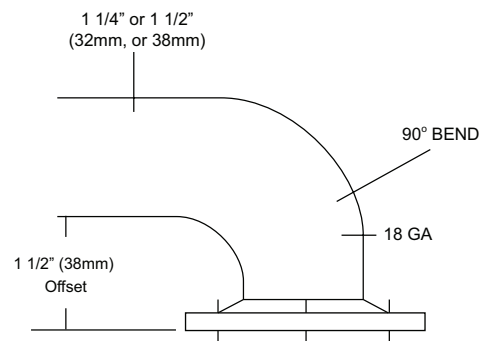

### NOTES



# UX110-BF

Single Robe Hook

Revision 03/11

JOB #:

ITEM #:

QUANTITY:

MOUNTING	HANDING	TYPE	SIZE	OTHER

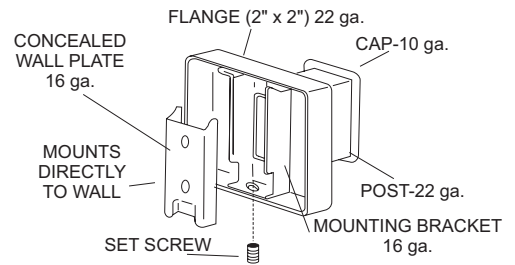
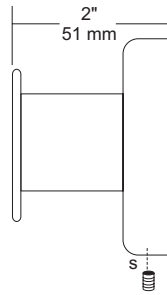
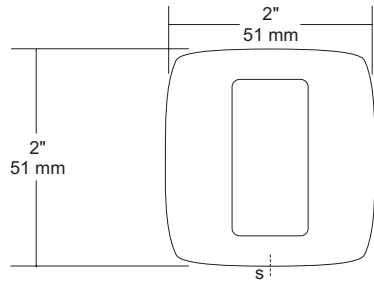

### SPECIFICATIONS

**UX Accessories:** All UX bath accessories series are fabricated of stainless steel with a bright or satin finish. Mounting plates are concealed with a snap-on type plate secured by a set screw.

**Hook:** #10 ga stainless steel hook.

**Flange:** 2" x 2" flange #22 ga stainless steel.

**Post:** #22 ga stainless steel.

**Mounting Plate:** #16 ga concealed wall plate. Set screw secures mounting plate and flange.

**Overall Size:** 2"W x 2"H x 1 5/8"D

**51mm x 51mm x 41mm**

**UX110-SF:** Same as UX110-BF with satin finish

### INSTALLATION

Provide an area on wall surface at desired or specified location. Place concealed mounting plate on wall surface and transfer mounting points. Drill pilot holes and secure with proper fasteners. Place snap on flange over plate and secure with set screw.

### NOTES



# UX111-BF

Single Towel Pin

Revision 03/11

JOB #:

ITEM #:

QUANTITY:

MOUNTING	HANDING	TYPE	SIZE	OTHER

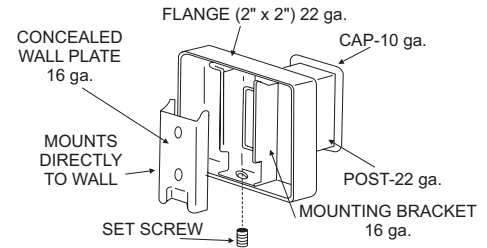
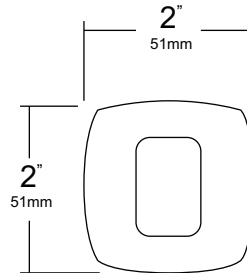
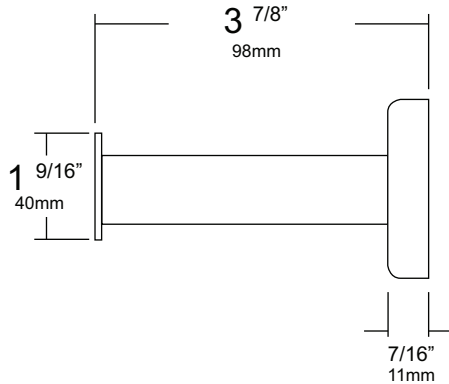

### SPECIFICATIONS

**UX Accessories:** All UX bath accessories series are fabricated of stainless steel with a bright or satin finish. Mounting plates are concealed with a snap-on type plate secured by a set screw.

**Hook:** #10 ga stainless steel hook

**Flange:** 2" x 2" flange #22 ga stainless steel.

**Post:** #22 ga stainless steel.

**Mounting Plate:** #16 ga concealed wall plate. Set screw secures mounting plate and flange.

**Overall Size:** 2"W x 2"H x 3 7/8"

**51mm x 51mm x 120mm**

**UX111-SF:** Same as UX111-BF only satin finish in lieu of a bright finish stainless steel.

### INSTALLATION

Provide an area on wall surface at desired or specified location. Place concealed mounting plate on wall surface and transfer mounting points. Drill pilot holes and secure with proper fasteners. Place snap on flange over plate and secure with set screw.

### NOTES