

date  
projectname  
attn  
from  
fax  
email  
phone

02/09/2021  
Aqaba Project  
.  
AL HARB FOR MEDICAL SUPPLIES



# U126 Soap Dispenser

Revision 11/14

JOB #:

ITEM #:

QUANTITY:

MOUNTING	HANDING	TYPE	SIZE	OTHER



### SPECIFICATIONS

**Soap Tank:** Fabricated of #20 ga stainless steel, #4 satin finish, fully welded one-piece construction.

**Valve:** All purpose antibacterial soap valve cylinder, black molded plastic push style valve that takes less than 5 lbs of force and one hand to operate complies with barrier free guidelines when mounted at proper height.

**Viewer:** Clear plastic window allows a constant fluid level check.

**Concealed Mounting Plate:** Fabricated of heavy gauge stainless steel.

**Filler Cap:** Fabricated of stainless steel, hinged to allow easy servicing, secured with special key that creates a vandal resistant dispenser.

**Overall Size:** 4 3/4"W x 8 1/4"H x 3 3/4"D (wall to valve)

**121mm x 210mm x 95mm**

**Capacity:** 40 oz.

**Recommend type soaps without chloric solutions for proper operation.**

### INSTALLATION

Provide an area on mounting surface at desired or specified location. Secure concealed mounting plate to wall surface with proper fasteners. Slide dispenser down over mounting plate and secure by means of set screw located inside tank. Fill unit with proper soap. Close lid and secure with special key. Test valve for proper operation.

\*It is not recommended to mount any soap dispenser on mirrors

\*\*For best performance, use pre-mixed low concentrate solutions. Dispensers should have periodic maintenance performed to insure the life dispenser. Rinse out globe and valve with warm water to avoid sludge buildup.

Preventative Maintenance: Each dispenser should be flushed out aprx. Every 30 days with warm water to prevent valve from clogging with old soap. Do not use abrasive cleaners to clean dispenser.

### NOTES

## U129PC

Vanity Mounted Soap Dispenser

Revision 07/11

JOB #:

ITEM #:

QUANTITY:

MOUNTING	HANDING	TYPE	SIZE	OTHER

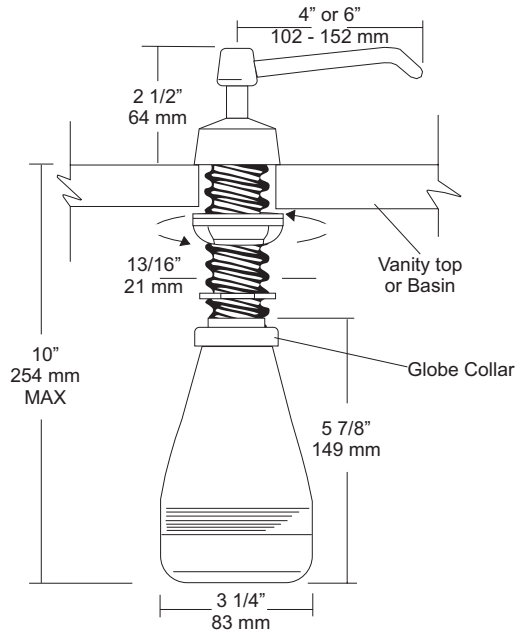

### SPECIFICATIONS

**Piston & Spout:** Highly polished corrosion resistant, stainless steel. Assembly rotates 360 degrees.

**Flange & Collar:** One piece highly polished chrome on brass.

**Valve Assembly:** All purpose bellows valve, fabricated of ABS material, with stainless steel return spring.

**Shank:** Chrome on brass, secured to collar. Special key provided that unlocks collar for servicing.

**Globe & Collar:** High impact translucent polyethylene.

**Capacity:** 16 fl oz

**U129PCA:** Same as U129PC with 6" (152mm) spout.

**Recommend type soaps without chloric solutions for proper operation.**

**\*All vanity soap dispensers are designed to be serviced above the counter**

### INSTALLATION

Provide a 7/8" - 1" diameter opening in vanity or basin. Insert shank through cut out and secure with supplied washers and wing nut. Connect supply tube with valve making sure notch end is at bottom. Secure globe and collar to shank. Fill globe above counter. Secure upper assembly to shank. Prime dispenser every time unit is serviced.

\*It is not recommended to mount any soap dispenser on mirrors

\*\*For best performance, use pre-mixed low concentrate solutions. Dispensers should have periodic maintenance performed to insure the life dispenser. Rinse out globe and valve with warm water to avoid sludge buildup.

Preventative Maintenance: Each dispenser should be flushed out aprx. Every 30 days with warm water to prevent valve from clogging with old soap. Do not use abrasive cleaners to clean dispenser.

### NOTES

Formerly Model #: U129-PC

JOB #:

ITEM #:

QUANTITY:

MOUNTING	HANDING	TYPE	SIZE	OTHER

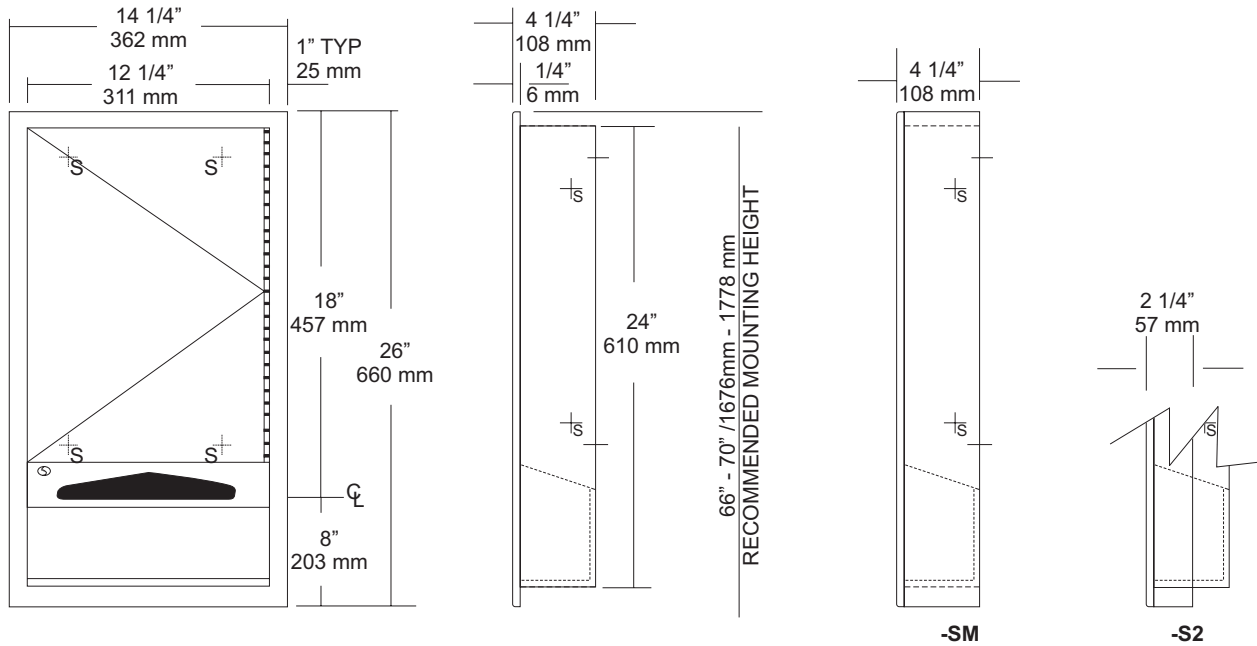

### SPECIFICATIONS

**Cabinet Body:** Fabricated of #22 ga stainless steel. Face trim is an integral part of body with a #4 satin finish and 1/4" returns to wall surface for rigidity. One piece construction without miters or welds.

**Cabinet Door:** Fabricated of #22 ga stainless steel with a #4 satin finish. Full length door stops protect door from vandalism.

**Cabinet Back:** Fabricated of #22 ga stainless steel with multiple welds to cabinet body:

**Towel Dispensing:** Hemmed edges that prevent injury and towel tearing.

**Hinges:** Heavy duty, full length, stainless steel piano type hinge secured door to cabinet.

**Lock:** Commercial quality, pin tumbler type lock keyed like all other AJW accessories.

**Collars:** Fabricated of #22 ga stainless steel finished to match cabinet for surface or recess mounting.

**Overall Size:** 14 1/4"W x 26"H x 4 1/4"D  
**362mm x 660mm x 108mm**

**Wall Opening:** 12 3/4"W x 24 1/2"H x 4"D  
**324mm x 622mm x 102mm**

**U230-S2:** 2" semi-recessed collar, 2" wall opening 51mm.

**U230-SM:** Full surface mounted collar.

**Capacity:** 600 c-fold or 800 multifold Towels

### INSTALLATION

Coordinate installation with architect and contractor to avoid interference with pipes vents etc. in wall. Provide a rough wall opening 12 3/4"W x 24 1/2"H. See specification for proper wall depth opening. Open cabinet and insert into wall opening. Secure with proper fasteners per each application. Fill unit with recommended towels, without overfilling. Make sure towels overlap each other so they will be available each time a towel is removed from dispensing area.

Do not use abrasive or chloric solutions when cleaning cabinet.

### NOTES



# U674

## Vanity Mounted Towel & Waste Door

Revision 03/11

JOB #:

ITEM #:

QUANTITY:

MOUNTING	HANDING	TYPE	SIZE	OTHER

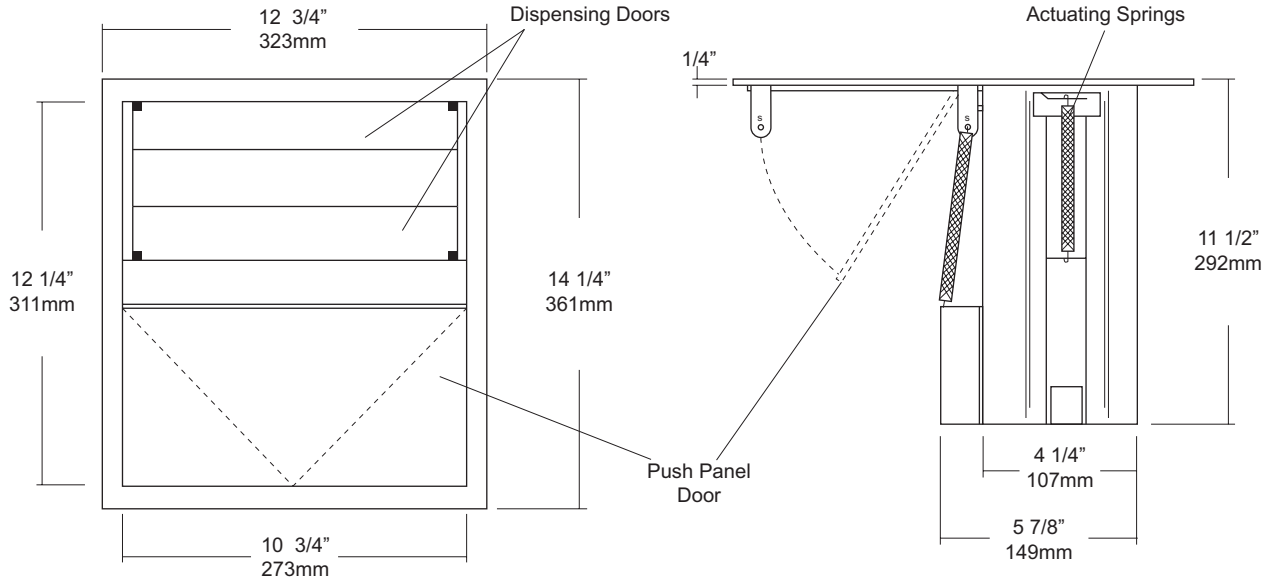

### SPECIFICATIONS

**Mechanism Guide / Body:** Fabricated of #22 gauge stainless steel that controls paper dispensing by means of 2 spring loaded dispensing doors and actuating springs.

**Door:** Assembly is fabricated of #22 gauge stainless steel with a #4 satin finish on all exposed surfaces. Push panel door will return to closed position by means of a return spring loaded mechanism.

**Flange:** Fabricated of #22 gauge stainless steel with a #4 satin finish with 1/4" returns.

**Overall Size:** 12 3/4"W x 14 1/4"L x 11 1/2"D  
**323mm x 361mm x 292mm**

**Counter Top Opening:** 11"W x 12 1/2"L  
**279mm x 318mm**

**Capacity:** 300 c-fold or 400 multifold towels

**Note:** Waste receptacle must be purchased separately.

### INSTALLATION

Coordinate installation with architect and contractor before providing a cut out in vanity to avoid interference with pipes. Provide cut out 11"W x 12 1/2"L. Install unit in opening and secure at four (4) points with proper fasteners (fasteners not provided). Load paper towels into unit by pushing down into unit through the flap doors and test dispensing of towels.

Waste receptacle must be ordered as a separate unit.

### NOTES

Formerly Model #: U974

MOUNTING	HANDING	TYPE	SIZE	OTHER

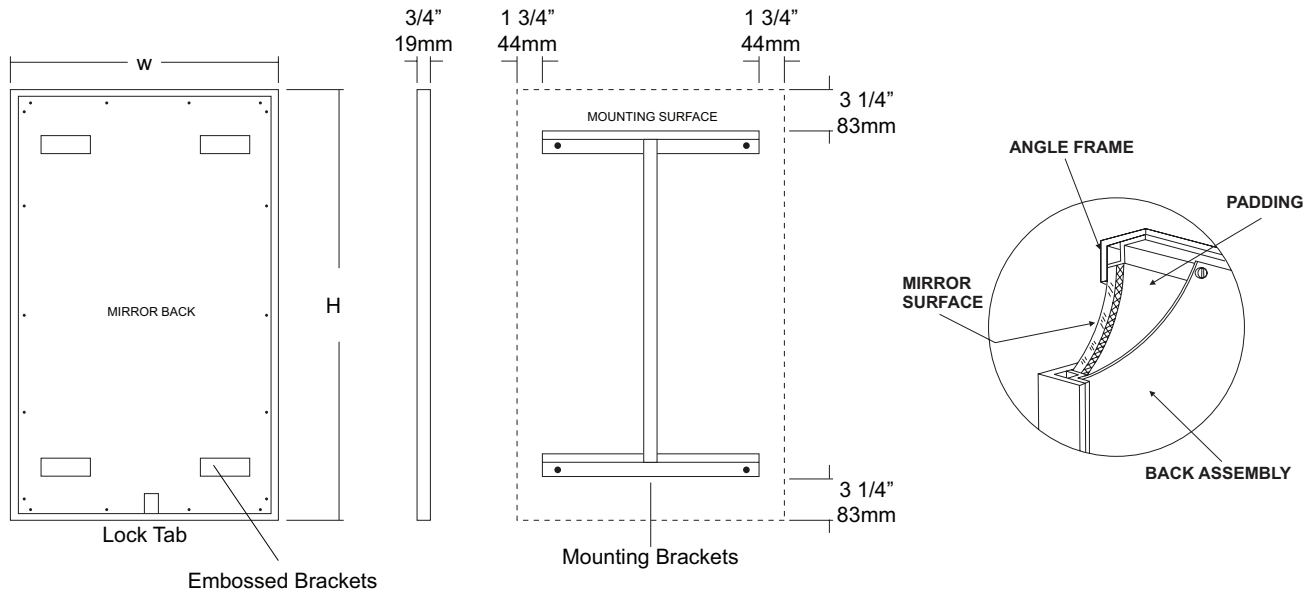

#### SPECIFICATIONS

**Frame:** Fabricated of #18 ga stainless steel, #4 satin finish. 3/4" x 3/4" frame with welded mitered corners are ground and polished smooth. #22 ga concealed "Z" channel is spot welded to inner perimeter of frame for reinforcement and greater rigidity.

**Mirror:** 1/4" thick type 1 transparent flat type, class 1 - clear glass mirrors. Mirror is coated with silver and sealed with a uniform electrolytic copper plating, along with two coats of paint for added protection. Mirrors are guaranteed against silver spoilage for a period of 15 years. Mirrors conform to ASTM C1036 and ASTM C1503-R8.

**Filler:** 3/16" thick full size, shock absorbing, water resistant, non-abrasive polyethylene padding protects all concealed mirror surfaces.

**Back:** #20 ga pre-plated galvanized steel, with embossed horizontal louver mounting brackets. Embossed theft resistant pressure activated clip lock device, locks mirror in place to wall hangers. Back is secured to frame with concealed Phillips head screws.

**Hangers:** Fabricated of #20 ga pre-plated steel galvanized steel with mounting points.

**Standard Sizes Available (W x H):** 16"x24", 16"x20", 16"x30", 18"x24", 18"x30", 18"x36", 20"x60", 24"x30", 24"x36", 24"x42", 24"x48", 18"x60", 24"x60", 24"x72", 18"x72"

#### Options:

- LG:** Laminated Glass
- LX:** Polycarbonate
- PM:** Plastic Acrylic
- T:** Tempered Glass
- VC:** Vinyl Clad (Safety Glass)
- 8B:** #8 Reflective Stainless Steel

\* Stainless steel mirrors reflect images in different optic quality than plate glass. There will be a slight distortion which increases proportionately with the mirror size. Therefore, AJW Architectural Products™ cannot be held responsible for quality of image.

\*\* Mirrors are always ordered Width x Height

\*\*\* Recommended max size for 8B mirrors: 72" x 47-1/2"

\*\*\*\* Framed mirrors are fabricated to a tolerance of (+/-) 1/8"

\*\*\*\*\* Mirrors conform to Federal Specifications DD-M-00411b & DDg-541D.

#### INSTALLATION

Coordinate installation with architect / contractor for specific mounting location and height for each mirror application. Making sure "I" bracket is level, transfer all mounting point locations to wall surface from drawing. Secure brackets with proper fasteners for each application. Slide mirror down over horizontal brackets until clip lock secures mirror in place. Mirror can only be removed by inserting tool through hole at bottom of frame depressing clip. This will allow mirror to slide up over brackets. Fillers are available if mirrors are mounted above and below tile line. (U004 Filler) filler material will match mirror frame to form a one piece construction.

To meet ADA Code, bottom edge of reflective surface can be no higher than 40" above finished floor. (4.19.6) Full length mirrors may be used for universal application when installed in correct locations.

Abrasive cleaners & chloric solutions should not be used on mirrors. Discoloring and /or scratching of frame and reflective surface may occur.

#### NOTES



# U934

## Retractable Shower Seat

Revision 1/14

JOB #:

ITEM #:

QUANTITY:

MOUNTING	HANDING	TYPE	SIZE	OTHER

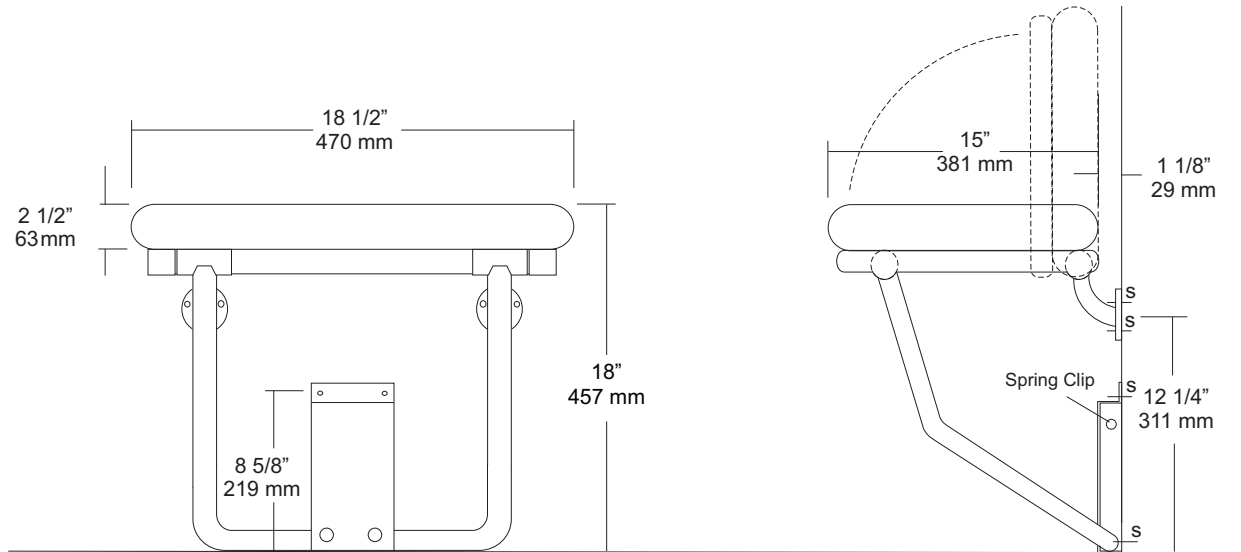

### SPECIFICATIONS

**Seat:** Fabricated of 2 1/2" thick water-resistant reinforced vinyl fabric cushion (white) seamless design with all leading edges having a radius. Seat is secured to a 1/2" thick marine plywood.

**Tubing:** Fabricated of #18 ga stainless steel with #4 satin finish.

**Main Frame:** Fabricated of #18 ga 1 1/4" with satin finish tubing. Underside has no exposed fasteners.

**Flanges:** #18 gauge stainless steel with four (4) countersunk exposed mounting points. Under slung supports have a 1 1/4" OD. (Satin finish)

**Mounting Bracket:** #14 ga stainless steel "hat" style bracket with 4 mounting support points. Bracket acts as a guide to raise and lower seat platform and is equipped with four (4) points to secure to wall surface. For maximum support, bracket is mounted so the bottom is set on the finished floor surface. Seat will remain in an upright position when not in use by means of a spring clip.

**Overall Size:** 18 1/2"W x 15"D (seating area)  
**470mm x 381mm**

**\*Wall to floor mounting design provides equal distribution of weight to ensure safe operation.**

### INSTALLATION

To comply with ADA Code, seat should be mounted at a height 17" - 19" above finished floor. Check all state and local codes for building requirements. Recommend in wall mounting on all shower seats. (BP10) Place seat up against wall making sure the extended part of seat has an offset no more than 1 1/2" away from wall. (Same as grab bar) Transfer mounting points to wall surface and drill pilot holes. Secure seat to surface with proper fasteners per each application. Snugly secure seat to surface and check seat to be level. If seat is level raise and lower seat to check path of travel. Finish securing seat after checking seat for proper operation. When properly mounted seat will support up to 250 lbs and will conform with ADA Code 4.21.3 and 4.26.3

Note: This shower seat is not intended to be installed in applications that have shower bases with rounded corners. AJW recommends the U928 for such applications.

### NOTES

Formerly Model #: U934-1A

JOB #:

ITEM #:

QUANTITY:

MOUNTING	HANDING	TYPE	SIZE	OTHER

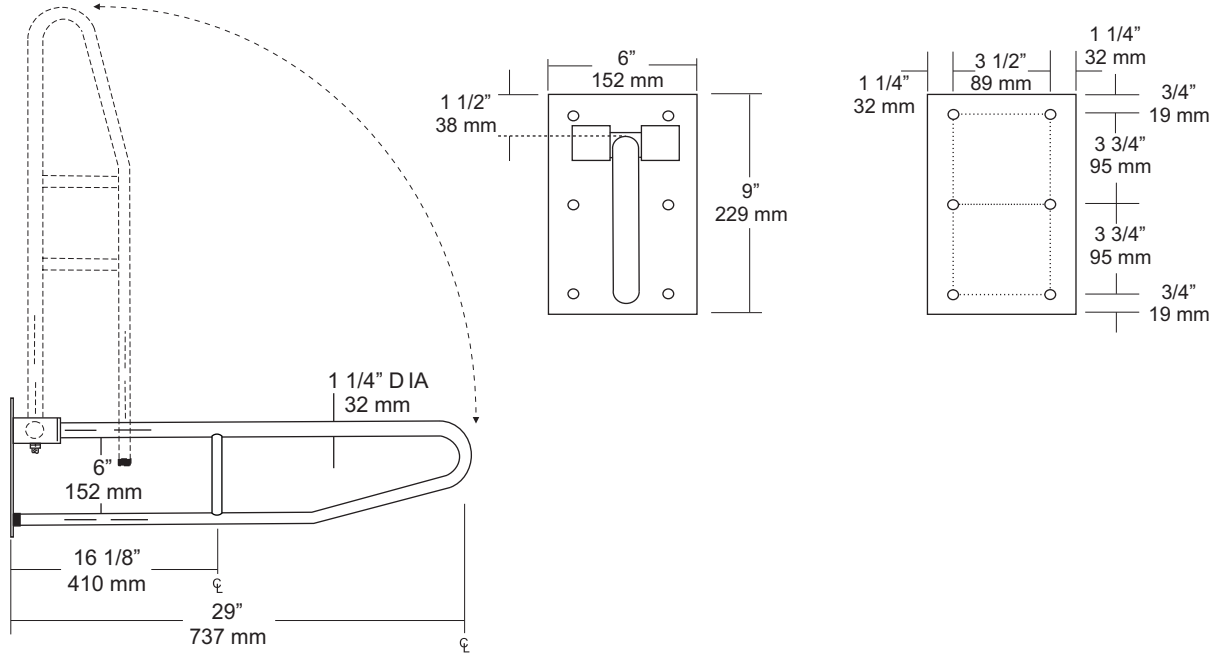

### SPECIFICATIONS

**Mounting Plate:** Fabricated of #11 ga stainless steel, #4 satin finish with 6, 1/4" dia exposed mounting points.

**Bar:** #18 ga, 1 1/4" diameter, stainless steel with a #4 satin finish. All bends formed by an automatic mandrel bending process which maintains a uniform bar diameter around bends.

**Gripping Surface:** Standard surface is satin finish. Use suffix X for peened grip. (Anti-slip)

**Intermediate Supports:** Same material as bar with contour cuts that are heliarc welded.

**Pivot Brackets:** Dual supports fabricated of #18 ga square stainless steel tube with capped ends.

**Tension Control Mechanism:** An adjustable clutch to control the amount of tension on the bar required to raise and lower the bar. This prevents bar from falling when in the up-right position.

**Check all state and local building codes for proper mounting heights and locations. ADA code specifies 33"-36" above finished floor for maximum mounting height.**

**When properly mounted, swing-up type bar will sustain a static load of 250 lbs.**

**Finish:**

-PC: White Powder Coat

### INSTALLATION

**Installation:** Coordinate installation with architect and contractor to avoid interference with toilet, stall doors, etc. Place unit on wall surface making sure unit is level, transfer mounting points and drill pilot holes. Secure unit with proper fasteners per application.

### NOTES





# UG2-A

Grab Bars

Revised 03/11

JOB #:

ITEM #:

QUANTITY:

MOUNTING	HANDING	TYPE	SIZE	OTHER

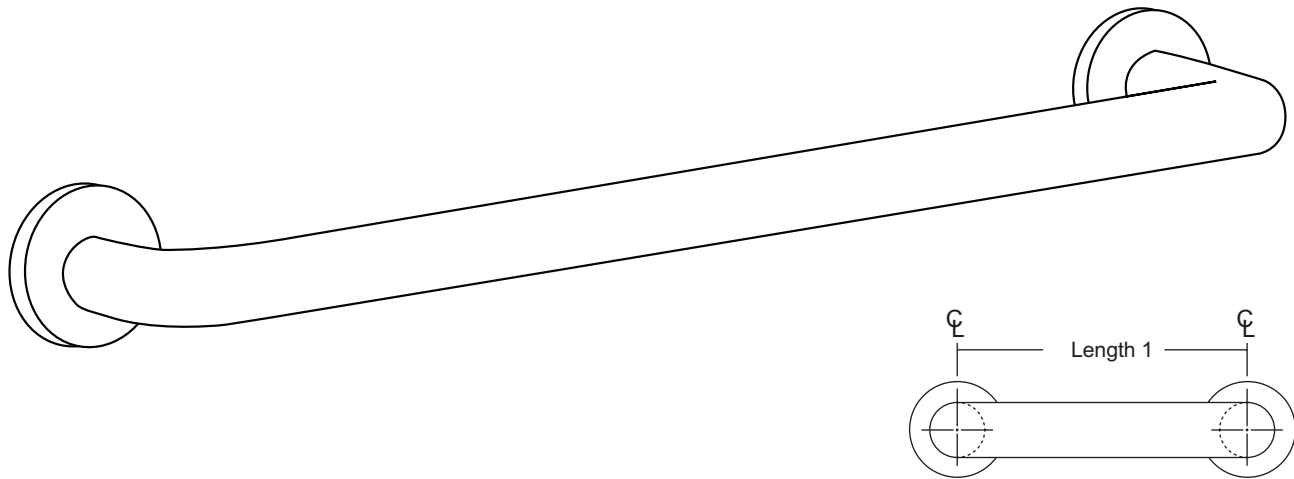

## SPECIFICATIONS & INSTALLATION

**Tubing:** Fabricated of #18 ga stainless steel with a #4 satin finish. Available in 1 1/4" outside diameter. All bends are formed by an automatic mandrel bending process. All bars maintain a constant 1 1/2" offset.

**Finish:** Standard finish is a #4 satin finish. For a non-slip finish (peened) add suffix X to model number. (Ex. UG2X-A)

**Flanges:** Snap flanges are fabricated of 3" diameter, 3/8" deep drawn #22 ga stainless steel with #4 satin finish to match tubing. Flanges have dimples that secure over mounting plate.

**Strength:** Bars with a 1 1/2" offset clearance will support loads in excess of 900lbs when properly installed. Bars with greater offsets will support loads up to 250lbs when properly installed.

**Installation:** Before installing grab bars, verify with all state and local codes for requirements on bar diameter and type finish. Recommended mounting heights for grab bars are 33" - 36" centerline above finished floor. All mounting of grab bars when possible should have in wall mounting back plates. Find centerline mounting points and place bar on line making sure to be on center. Transfer mounting points (3 per flange) to wall. Drill pilot holes and secure bar with proper anchors per application. Snap cover over mounting plate.

**Standard Lengths (Other sizes available upon request):** 12", 16", 18", 24", 30", 32", 36", 42", 48", 50", 52", 54", 56"

## FLANGE INFORMATION

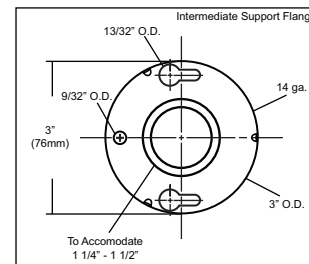
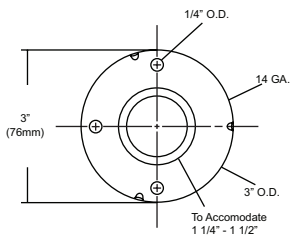
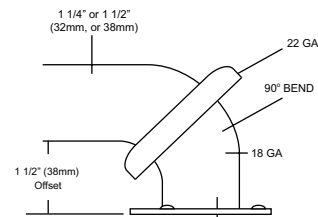

## NOTES



# UX1-V Overhead Supports

Revision 03/11

JOB #:

ITEM #:

QUANTITY:

MOUNTING	HANDING	TYPE	SIZE	OTHER

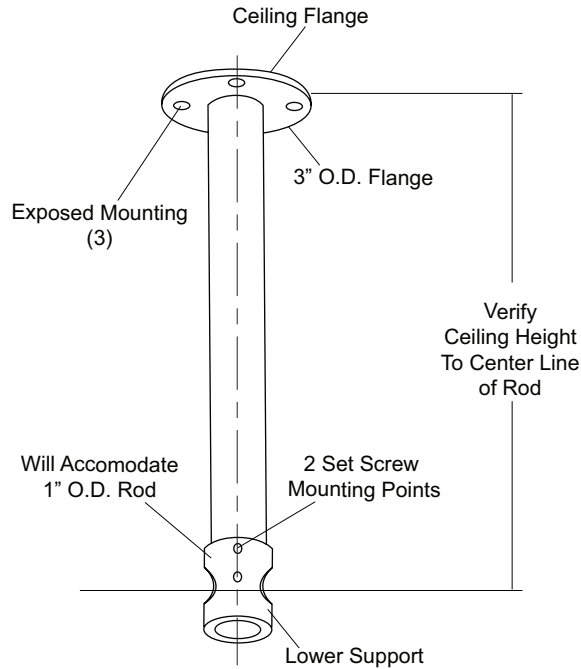

### SPECIFICATIONS

**Rod:** Fabricated of #18 gauge stainless steel tube with a #4 satin finish.  
**Flange:** Ceiling mounted exposed flange has a 3" O.D. With three exposed mounting points.  
**Support:** Machined aluminum with a satin finish. Unit will accommodate 1" OD shower rod  
**UX1-V:** 1"OD

### INSTALLATION

Provide an area on ceiling at desired or specified location. Transfer mounting points and drill pilot holes. Secure flange with proper fasteners per each application. Slide lower support over vertical rod end and secure with supplied set screw. Do not finish securing support to rod to make adjustments. Slide shower rod through support opening and secure to rod flanges. After shower rod is secured to flanges and checks to be level finish securing rod and support with supplied set screws (2). Recommend overhead supports for all rods over 72" and other configurations than straight runs.

### NOTES

Formerly Model #: UX168



# UX110-BF

Single Robe Hook

Revision 03/11

JOB #:

ITEM #:

QUANTITY:

MOUNTING	HANDING	TYPE	SIZE	OTHER

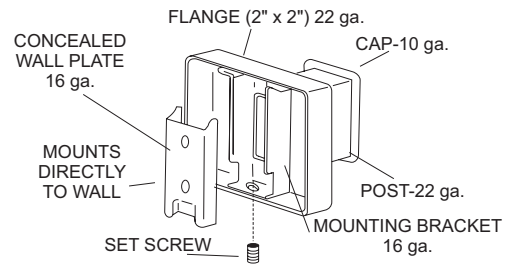
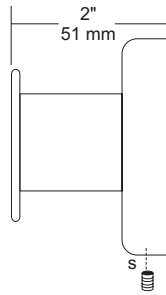
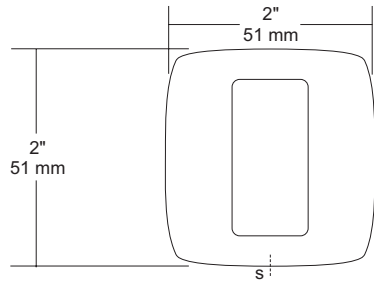

### SPECIFICATIONS

**UX Accessories:** All UX bath accessories series are fabricated of stainless steel with a bright or satin finish. Mounting plates are concealed with a snap-on type plate secured by a set screw.

**Hook:** #10 ga stainless steel hook.

**Flange:** 2" x 2" flange #22 ga stainless steel.

**Post:** #22 ga stainless steel.

**Mounting Plate:** #16 ga concealed wall plate. Set screw secures mounting plate and flange.

**Overall Size:** 2"W x 2"H x 1 5/8"D

**51mm x 51mm x 41mm**

**UX110-SF:** Same as UX110-BF with satin finish

### INSTALLATION

Provide an area on wall surface at desired or specified location. Place concealed mounting plate on wall surface and transfer mounting points. Drill pilot holes and secure with proper fasteners. Place snap on flange over plate and secure with set screw.

### NOTES

## UX131-BF Series Square Towel Bar

Revision 03/11

JOB #:

ITEM #:

QUANTITY:

MOUNTING	HANDING	TYPE	SIZE	OTHER

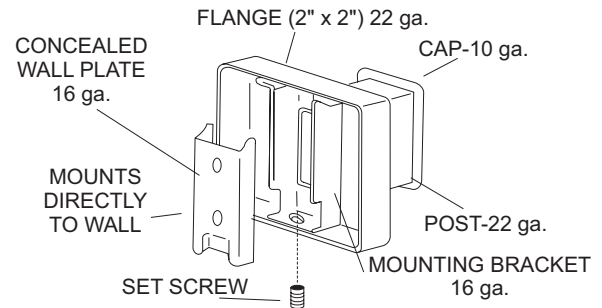
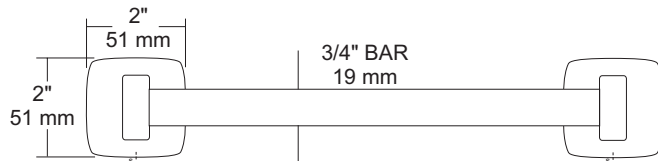
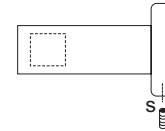
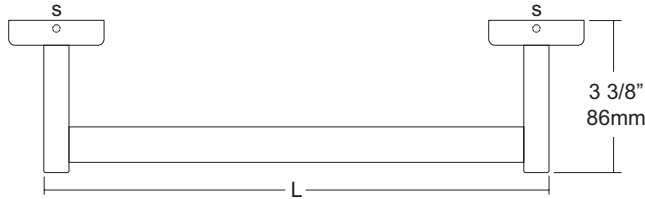

### SPECIFICATIONS

**UX Accessories:** All UX bath accessories series are fabricated of stainless steel with a bright or satin finish. Mounting plates are concealed with a snap-on type plate secured by a set screw.

**Flange:** 2" x 2" flange #22 ga stainless steel.

**Post:** #22 ga stainless steel.

**Bar:** #22 ga stainless steel, 3/4" dia

**Mounting Plate:** #16 ga concealed wall plate. Set screw secures mounting plate and flange.

**Standard Lengths:** 18", 24", 30", 36" (475mm, 610mm, 762mm, 914mm)

**Overall Size:** 2"H x 3 3/8"D (51mm x 86mm)

**UX131-SF:** Same as UX131-BF with satin finish.

### INSTALLATION

Provide an area on wall surface at desired or specified location. The centerline distance between the mounting plates is 1/2" less than the length of the towel bar. Place concealed mounting plate on wall surface and transfer mounting plate on wall surface and transfer mounting points. Drill pilot holes and secure with proper fasteners. Place snap-on flange over plate and secure with set screw. Repeat same step for second post. Place towel bar in post and place cover over plate to make sure spread is correct. Secure cover if bar fits.

### NOTES



# UX141-BF

Toilet Tissue Dispenser

Revision 03/11

JOB #:

ITEM #:

QUANTITY:

MOUNTING	HANDING	TYPE	SIZE	OTHER

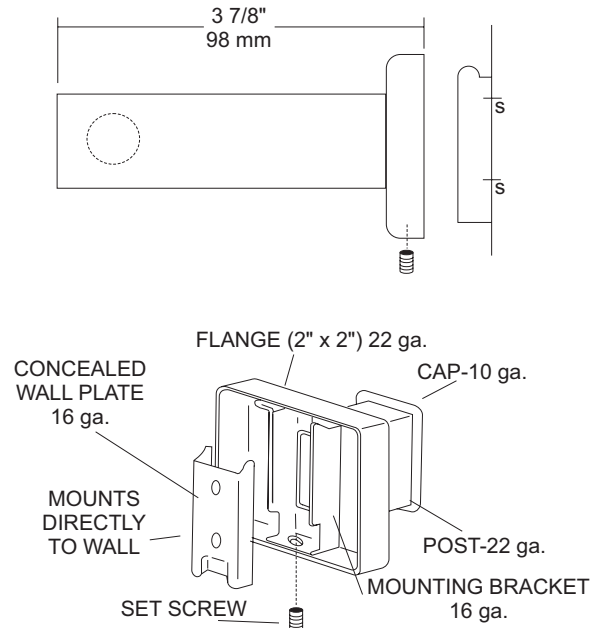
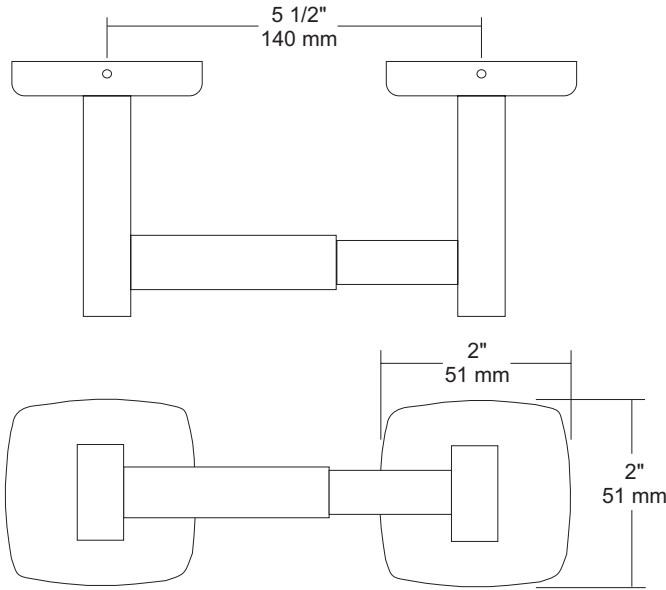

### SPECIFICATIONS

**UX Accessories:** All UX bath accessories series are fabricated of stainless steel with a bright or satin finish. Mounting plates are concealed with a snap-on type plate secured by a set screw.

**Flange:** 2" x 2" flange #22 ga stainless steel.

**Post:** #22 ga stainless steel.

**Mounting Plate:** #16 ga concealed wall plate. Set screw secures mounting plate and flange.

**Spindle:** Spring loaded, chrome plated plastic.

**Optional U007 Theft Resistant Adapter:** Prevents spindle from being removed until roll has been depleted.

**Overall Size:** 7 1/2" W x 2"H x 1 5/8"D

**51mm x 51mm x 43mm**

**UX141-SF:** Same as UX141-BF with satin finish

### INSTALLATION

Provide an area on wall surface at desired or specified location. Place concealed mounting plate on wall surface and transfer mounting points. Drill pilot holes and secure with proper fasteners. Place snap-on flange over plate and secure with set screw. Centerline space between posts is aprx. 5 1/2"W. Repeat same steps for other post. Place a roll of tissue on spindle and place in posts before securing the covers down securely. If roll spins freely, secure post with set screw. All toilet tissue dispensers must have a non-control delivery to meet ADA code. (4.16)

### NOTES

JOB #:

ITEM #:

QUANTITY:

MOUNTING	HANDING	TYPE	SIZE	OTHER

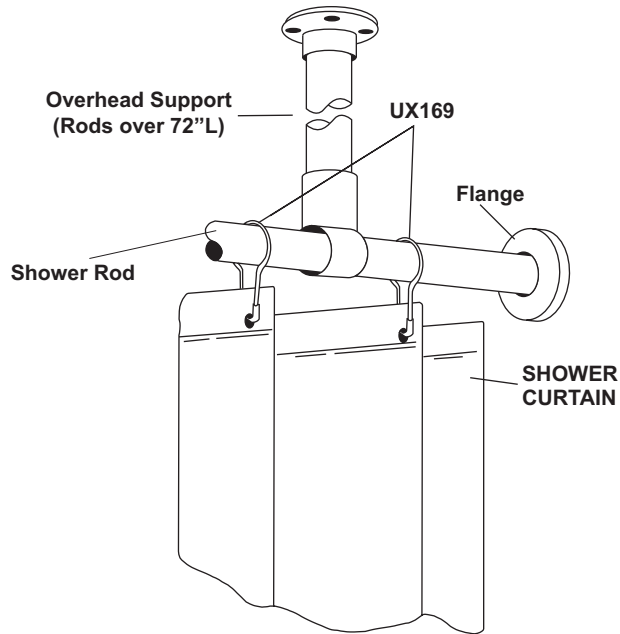

SPECIFICATIONS	INSTALLATION
----------------	--------------

**U250A:** Fully reinforced, wide top hem and reversed bottom hem to prevent water and soap from collecting. Each is equipped with rust proof nickel grommets spaced aprx. 6" on center and down 3/4" from top edge. When determining size of curtain required, consider the desired fullness and add 10" to the shower rod length.

**U250A:** Anti-Bacterial, flame resistant, self deodorizing fabric. Fabric is non-toxic and contains a patented dual agent antimicrobial system. Provides around the clock effectiveness against cross-infection hazards, reducing growth of viable diseases and odor forming organisms on their surfaces. Curtains are flame resistant and offer permanent protection against the dangers of accidental fires.

**Curtain Hooks (UX169):** Unit is constructed of stainless steel. Ring snaps around the shower rod to support curtain. Spacing of hooks is every 6" and can be installed on both 1" & 1 1/4" diameter rods.

**Colors Available:** White, Beige, Medium Blue, Green, Mauve, Frosty, Blush, Claret, Parchment, Yellow & Jade.

**\*UX1-V/UX2-V:** Overhead s/s supports for oversized shower rods. (For shower rods over 72" in length an overhead support is recommended)

**UX1-V:** 1" OD shower rods.

**UX2-V:** 1 1/4" OD shower rods.

Recommended: UX169 stainless steel shower curtain hooks to connect to AJW shower curtain rods. Various types of flanges are available to secure rod and curtain to mounting surface (exposed and concealed).

Measuring Curtains: Curtains are measured W x H. The same curtain will fit a 1 or 1 1/4" diameter rod.

**NOTES**

Formerly Model #: 250A