

date
projectname
attn
from
fax
email
phone

03302020
Christ the King School
Kermit Stuzman
Ray Lukowski

rayl@wilcodistributing.com
574.306.1465

VISUAL DISPLAY PRODUCTS



AJW
.....
Architectural Products™



▀ Culture • Focus • Results™

At AJW, our culture is our company. With that in mind, we focus on the mechanics that support a high-performance team. Transparency, communication, discipline, and focus are cornerstones of our operational behavior.



TABLE OF CONTENTS

About AJW	1	Display Rails	11
Markerboards	3	Combination Boards	13
Trim / Tray Options	5	Display Cases	14
Tackboards	6	Horizontal Sliders	15
Tackboard Color Charts	7	Bulletin Boards	17
Nomenclature	9	Conference Units	18
Tackwall	10	Glass Markerboards	19



▶ American Manufacturing

With manufacturing facilities in New York and Texas, AJW can respond with agility and precision to even the most complex initiatives. From high-style custom projects to a demanding scope of work, AJW has the team, infrastructure and experience to deliver results you can be confident in.

▶ Intelligent Sourcing

At AJW, we build partnerships that last. Many of our legacy partners have complemented our manufacturing capabilities for nearly 50 years. Consequently, we continue to leverage the depth, breadth, and strength of our supply chain to drive results and expand our distribution network globally.

▶ Better Results

High performance results are our priority. American manufacturing and intelligent sourcing allow us to leverage our in-house capabilities and our proven network of partners so that we are able to respond when it counts.



Focused on ServiceSM

▶ We Are AJW

For nearly 50 years, we have Focused on ServiceSM. As a result, our infrastructure is customer driven. We listen so that we understand your goals and objectives. We tailor our efforts and direct our action to be in concert with your needs. We measure our success by the health of our partnerships. American manufacturing, precise supply chain management and a focused culture are the fuel for better results. We are AJW.



AJW
Architectural ProductsTM

509 Temple Hill Road

MARKERBOARDS

▶ AJW porcelain on steel writing surfaces provide the ideal communication platform to share your ideas, debate your plan, and review your results. AJW Markerboards are fabricated using a three-ply construction process, including a porcelain enamel writing surface with a lifetime warranty. Your AJW Markerboard can be designed with a number of trim, tray and maprail options.

▶ SPECIFICATIONS

Balanced, high pressure laminated, porcelain enamel markerboards of three-ply construction consisting of face sheet, core material, and backing.

- Magnetic for use with dry erase markers
- 1/2" Core with aluminum backing sheet
- Excellent writing and erasing performance
- Lifetime warranty on porcelain enamel writing surface

AJW's porcelain enameled surface conforms to the standards set forth by the Porcelain Enamel Institute (PEI), and is backed by a lifetime warranty. The face sheet is comprised of enameling grade steel specially processed for temperatures used in coating porcelain on steel. Exposed face and edges are coated with a 3-coat process consisting of primer, ground coat, and color cover coat. Concealed face is coated with a 2-coat process consisting of primer and ground coat. Cover and ground coats are fused to steel at firing temperatures of approximately 1475°.

▶ STANDARD SIZES

2' x 3'	4' x 16'
4' x 3'	5' x 4'
4' x 4'	5' x 5'
4' x 5'	5' x 6'
4' x 6'	5' x 8'
4' x 8'	5' x 10'
4' x 10'	5' x 12'
4' x 12'	5' x 14'
4' x 14'	5' x 16'

Custom sizes available

MARKERBOARDS



▶ PRODUCT OPTIONS

Maprail Accessories



Flag Holder



Roller Bracket



Map Hook

Screen Print



Music Lines

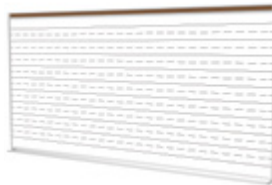

Penmanship Lines



Graph Coordinates



Polar Coordinates

AJW graphic boards are fabricated with imprinted lines that are UV-Resistant, scratch resistant, and permanently fused to the porcelain enamel writing surface.

TRIM & TRAY DETAIL

Trim Options

Flat Trim - 3/4" Profile

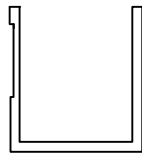
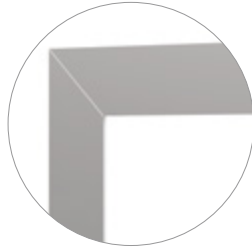
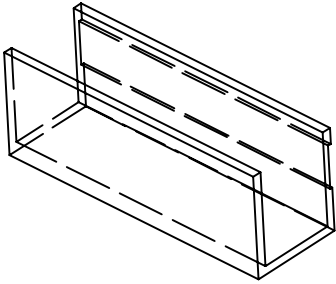

Wide Flat Trim - 1 1/4" Profile

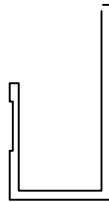
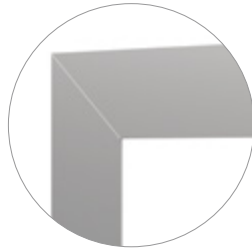
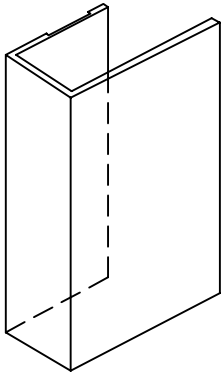

Box Trim - 1 1/2" Profile

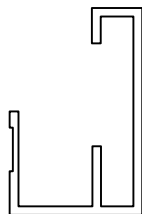
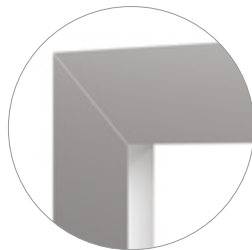
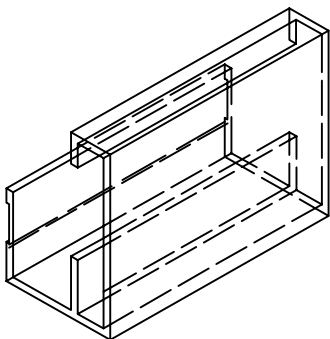

Tray Options

Flat Tray
(Plastic Endcaps)

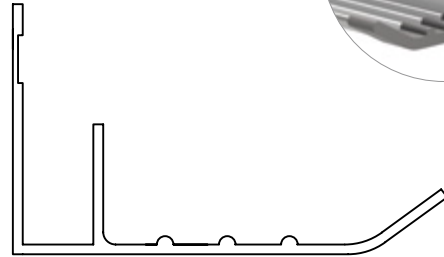

Box Tray
(Aluminum Endcaps)

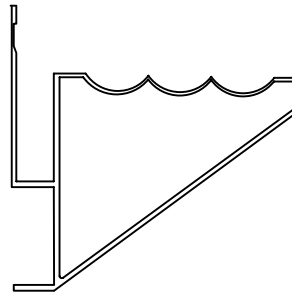

Powder Coating Color Options

Aluminum components come standard with a clear anodized finish.



Ivory
(0012)

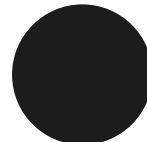

Black
(0029)

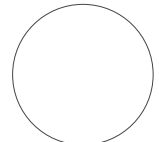

Winter White
(0028)

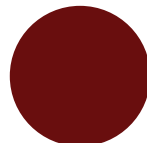

Burgundy
(0025)



Marine Blue
(0020)

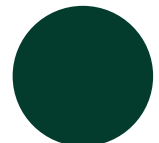

Hunter Green
(0017)

TACKBOARDS

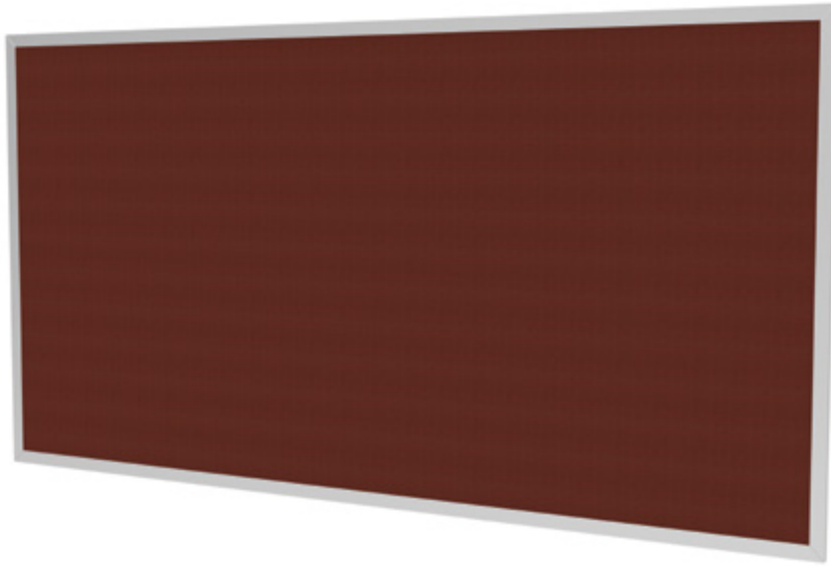

▶ AJW Tackboards are the ideal tool to enhance your communication strategy. Improve the use of your tackboard and complement the design by choosing from one of many trim and maprail options. You can further personalize your tackboard by selecting from a number of tackable surface options that include: natural cork, colored cork, vinyl fabric, and designer fabric.

▶ OPTIONS

Maprail

1" or 2" Maprail option, with numerous tackable insert options available including: natural cork, colored cork, vinyl faced, and fabric faced. Maprail is designed to be used with map hooks and flag holders.

Construction

- Framed Option
- Wrapped Option (Vinyl & Fabric Only)

Tackable Surface Materials

- Natural Cork
- Colored Cork
- Designer Fabric
- Type 1 Vinyl Fabric
- Type 2 Vinyl Fabric

▶ STANDARD SIZES

2' x 3'

4' x 3'

4' x 4'

4' x 5'

4' x 6'

4' x 8'

4' x 10'

4' x 12'

4' x 14'

4' x 16'

Custom sizes available upon request

TACKBOARDS

TACKABLE SURFACE OPTIONS



Natural Cork

Natural Cork Tackboards

High-pressure laminated pure grain natural cork tackboards of two-ply construction consisting of natural cork face sheet and backing. AJW natural cork is self-healing and all natural.

Face Sheet and Core Options:

- 1/8" Natural Cork on 3/8" Fiberboard
- 1/4" Natural Cork on 1/4" Hardboard



Colored Cork (Forbo)

Colored Cork Tackboards

Linoleum, resilient tackable surface material, 1/4" thick with integral color throughout, laminated to burlap backing. AJW colored cork is washable, self healing, and resistant to bacteria. This cork is also known as Forbo Cork, or plastic impregnated cork. AJW offers a full range of standard colors.

Face Sheet and Core Options:

- 1/4" Colored Cork on 1/4" Hardboard

Edge Options

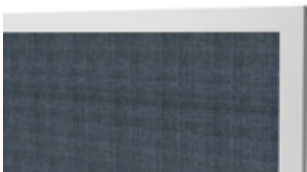

Framed



Wrapped Edge

Colored Cork

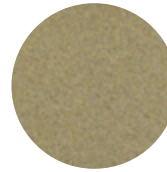

Desert Sand
(2067)

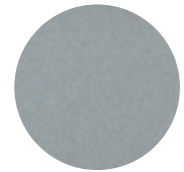

Grey
(2162)



Tan
(2166)



Stone
(2182)

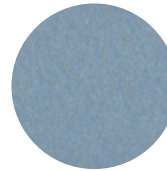

Blue
(2185)



Buff
(2186)



Fawn
(2187)

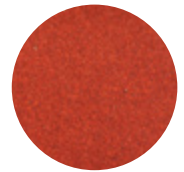

Red
(2201)

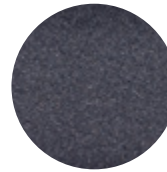

Black
(2202)



Green
(2203)

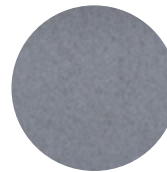

Graphite
(2204)

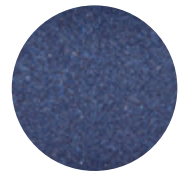

Midnight Blue
(2205)

TACKBOARDS

TACKABLE SURFACE OPTIONS

Designer Fabric

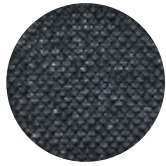

Black
(5001)



Wheat
(5002)



Pearl
(5003)

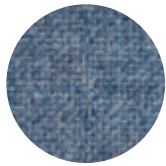

Wedgewood
(5004)

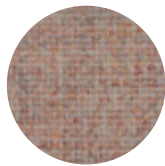

Cherry Neutral
(5005)

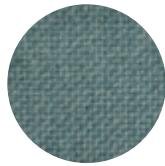

Blue Spruce
(5006)

Designer Fabric Tackboards

100% recycled polyester decorative designer fabric faced cork tackboards of three-ply construction consisting of designer fabric face sheet, core material, and backing. AJW offers a full range of standard colors. Custom colors are available upon request.

Face Sheet and Core Options:

- Designer Fabric, 1/8" Natural Cork, and 3/8" Fiberboard
- Designer Fabric, 1/4" Natural Cork, and 1/4" Hardboard
- Designer Fabric on 3/8" Fiberboard (Wrapped Edge Only)
- Designer Fabric on 1/2" Fiberboard

Vinyl Type I

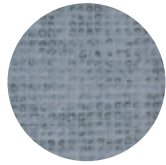

Denim
(3001)



Bleached
(3002)

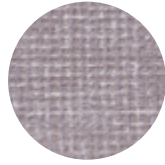

Windrift
(3003)



Taupe
(3004)

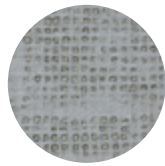

Platinum
(3005)

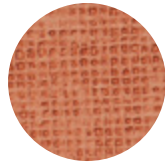

Persimmon
(3006)

Vinyl Type II



Cotton White
(4001)

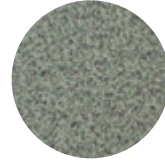

Moss
(4002)



Buttercup
(4003)



Stone
(4004)

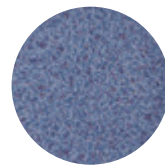

French Blue
(4005)

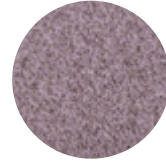

Amethyst
(4006)

Vinyl Covered Tackboards

High pressure laminated vinyl fabric faced cork tackboards of three-ply construction consisting of vinyl fabric face sheet, core material, and backing. AJW vinyl fabric complies with G.S.A. CCC-W-408 and the CFFA 101C quality standard for vinyl coated fabric wall covering. Both Type I and Type II vinyl fabric is available.

AJW offers a full range of standard colors. Custom colors are available upon request.

Face Sheet and Core Options:

- Vinyl Fabric, 1/8" Natural Cork, and 3/8" Fiberboard
- Vinyl Fabric, 1/4" Natural Cork, and 1/4" Hardboard
- Vinyl Fabric on 3/8" Fiberboard (Wrapped Edge Only)
- Vinyl Fabric on 1/2" Fiberboard

NOMENCLATURE

MARKERBOARDS

Series Prefix	Trim / Tray Style	Map Rail	Tackable Insert Suffix
N10 – Particleboard Core	1 – Flat Trim / Flat Tray	0 – No Map Rail	N – Natural Cork
	2 – Flat Trim / Box Tray		
N11 – Hardboard Core	3 – Wide Flat Trim / Flat Tray	1 – 1” Map Rail	C – Colored Cork
	4 – Wide Flat Trim / Box Tray	2 – 2” Map Rail	A – Type I Vinyl
	6 – Box Trim / Box Tray	5 – Grip Rail	B – Type II Vinyl
	B – Box Trim / No Tray	6 – 2” Tackable Grip Rail	Z – Designer Fabric
	F – Flat Trim / No Tray		
	W – Wide Flat Trim / No Tray		

Basis-of-Design Series: [Series Prefix] + [Trim/Tray Style] [DASH] [Map Rail] + [Tackable Insert]

Example 1: N101-1N Series (Particleboard Core, Flat Trim, Flat Tray, 1” Map Rail, Natural Cork Insert)

Example 2: N11B-0 Series (Hardboard Core, Box Trim, No Tray, No Map Rail)

Notes:

A tackable insert suffix is not required if there is no map rail.

TACKBOARDS

Series Prefix	Trim Style	Map Rail	Tackable Insert Suffix
N21 – 1/4” Hardboard Core	B – Box Trim	0 – No Map Rail	N – Natural Cork
N22 – 3/8” Fiberboard Core	F – Flat Trim	1 – 1” Map Rail	C – Colored Cork
N23 – 1/2” Fiberboard Core	W – Wide Flat Trim	2 – 2” Map Rail	A – Type I Vinyl
	0X – Untrimmed, with wrapped edges	5 – Grip Rail	B – Type II Vinyl
		6 – 2” Tackable Grip Rail	Z – Designer Fabric

Basis-of-Design Series: [Series Prefix] + [Trim Style] [DASH] [Map Rail] + [Tackable Surface]

Example 1: N21W-2C Series (1/4” Hardboard Core, Wide Flat Trim, 2” Map Rail, Colored Cork)

Example 2: N23B-0B Series (1/2” Fiberboard Core, Box Trim, No Map Rail, Type II Vinyl)

Notes:

- Colored Cork N/A for N22 and N23 series; Natural Cork N/A for N23 series.
- Map Rail tackable insert typically matches the tackable material of the board itself.
- Use “0X” as a trim style to designate an untrimmed board, with no maprail, with fabric wrapped edges (Designer Fabric, Type I vinyl, or Type II vinyl only) (ex. N230X-0A Series)

TACKWALL



▾ TACKWALL SPECIFICATIONS

AJW Tackwall enables you to transform an entire room into the ideal work, play, or creative environment. Our designer friendly surface material options include - colored cork, natural cork, type 1 or 2 vinyl and designer fabric. H-bars can be applied or panels can butt together, supporting a streamlined final product. Optional “J” trim is available to trim the sides, top, and bottom of the wall.

DISPLAY RAILS

▶ **AJW Display Rails** provide the ability to display information without sacrificing valuable space on your wall. Choose from our wide selection of tackstrips, grip rails, and tackable grip rails for a product that fits your needs.

▶ SPECIFICATIONS

Tackstrips

Aluminum tackstrips come with two end caps and are available with any type of tackable cork insert desired (natural cork, colored cork, vinyl faced, fabric faced). 1" and 2" tackstrips are designed to be used with map hooks, roller brackets and flag holders.

Grip Rail

Aluminum display rail with integral paper holder, consisting of plastic rollers that grip paper firmly. Grip rail is installed with snap-on plastic clips. Paper is easily removed by lifting bottom edge in an upward direction.

Tackable Grip Rail

Aluminum frame that combines the tackstrip and grip rail functions, and is comprised of a tackable cork insert on the front face with an integral paper holder, consisting of plastic rollers that grip paper firmly.

▶ STANDARD SIZES

4' L

6' L

8' L

10' L

12' L

14' L

16' L

Custom sizes available upon request

▶ SURFACE OPTIONS

- Natural Cork
- Colored Cork
- Designer Fabric
- Type I Vinyl
- Type II Vinyl

Color chart available on Page 8.

DISPLAY RAILS

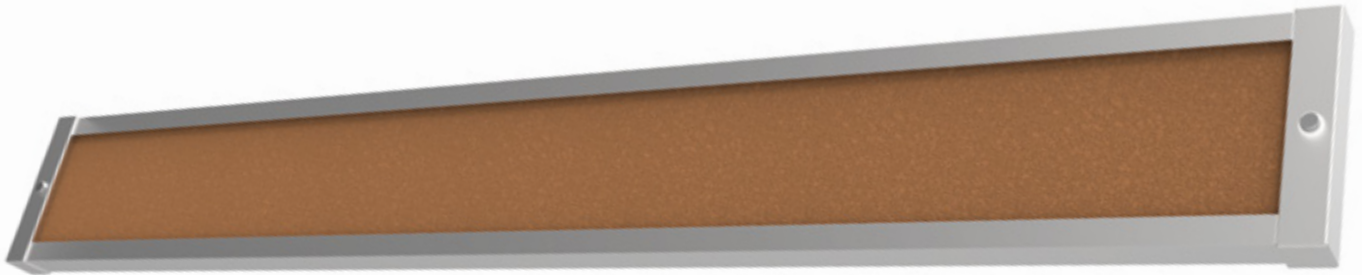

1", 2", 3", 4" Profiles available



Grip Rail



Tackable Grip Rail
2" Profile Only

Accessories

Accessories included for 1" and 2" tackstrips.



Flag Holder



Roller Bracket



Map Hook

COMBINATION BOARDS

▶ **AJW Combination Boards** are available in endless configurations, and they are available in your choice of trim style, board type, and board arrangement. Panels are available in sizes of up to 4' high x 16' wide and are joined with H-Bar assemblies. View the layouts below for typical markerboard / tackboard configurations, and contact your AJW Relationship Manager for assistance with designing your custom board.

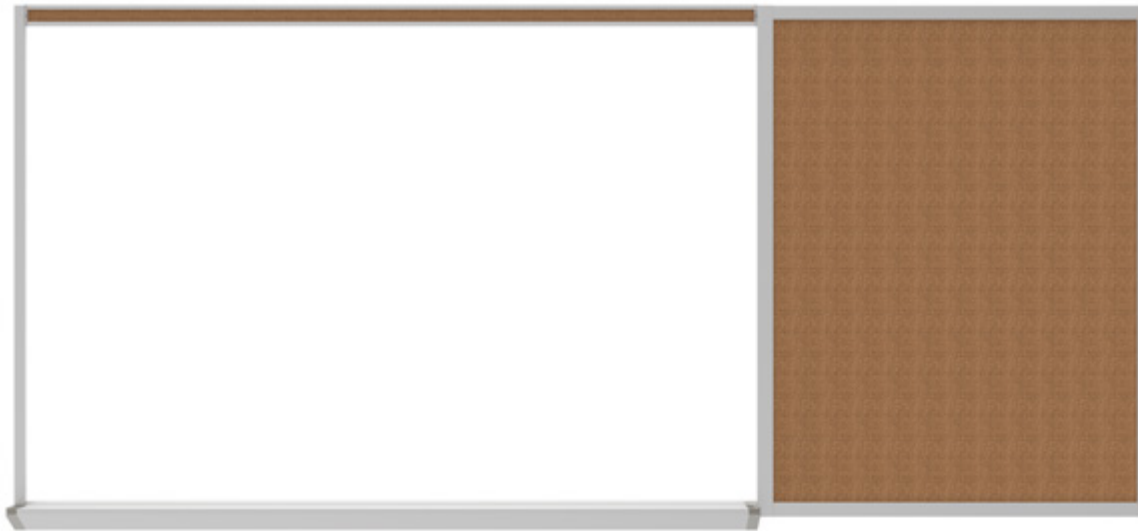

▶ TYPICAL MARKERBOARD & TACKBOARD CONFIGURATIONS

More combinations available.



DISPLAY CASES

▶ **AJW Display Cases** are fabricated to be durable and are designed as a streamlined unit, enabling you to showcase your team's accomplishments with confidence. Available in surface mounted or recessed, AJW display cases can be built with a number of different options.



▶ WOOD LAMINATE COLORS



Natural Maple
(7001)



Amber Maple
(7002)



Wild Cherry
(7003)



Select Cherry
(7004)

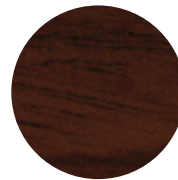

Mahogany
(7005)



Walnut
(7006)

▶ DISPLAY CASE SPECIFICATIONS

- Surface mounted and recessed options available.
- Heavy gauge extruded aluminum housing, with standard clear anodized finish.
- Powder coating options available (See color chart on page 5)
- Tackable back panel available in colored cork, vinyl faced, designer fabric, or natural cork.
- Optional wood side, top, and bottom panels with a depth of up to 24" available in AJW's standard laminate finishes, 16" depth standard.
- 1/4" thick tempered safety glass. Sliding and hinged type doors available.
- Hinged door display cases have continuous piano hinges and are equipped with keyed tumbler locks. Sliding door display cases are equipped with keyed sliding ratchet locks.
- 3 adjustable 1/4" tempered glass shelves with brackets for attachment to vertical standards.
- Optional top mounted fluorescent light.
- Sizes available in 4' and 6' height, up to 16' wide.

HORIZONTAL SLIDING UNITS

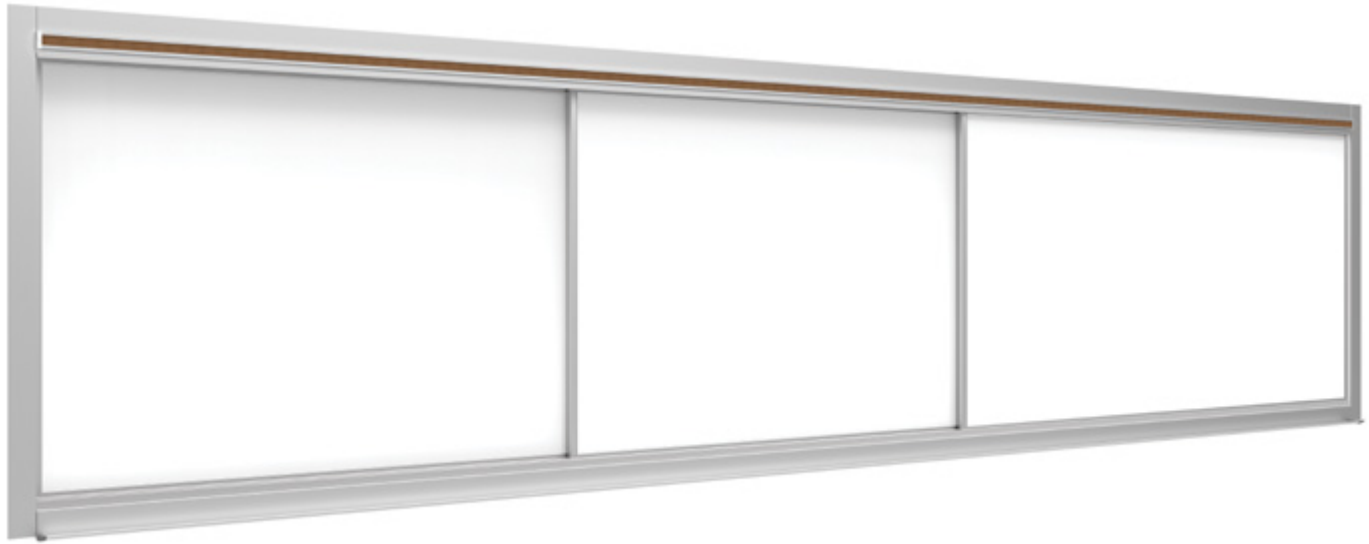

AJW Horizontal Sliders can double or triple your workspace and are customizable to accommodate your specific project requirements. Available in surface mounted or recessed, AJW sliding units can be designed with a number of panel, trim, tray and display rail options.

▸ SLIDING UNIT SPECIFICATIONS

- Sliding panels are manually operated and smoothly slide over aluminum top track on nylon ball bearing rollers.
- Trim and panel edging fabricated of heavy gauge extruded aluminum with satin anodized finish.
- Surface mounted or recessed mounting styles available.
- Optional back panel is available as a porcelain enamel markerboard or tackboard in natural cork, colored cork, designer fabric, Type I, or Type II vinyl. Having no fixed panel will allow access to cabinets, shelves, or other storage spaces.
- Choose from 2, 3, or 4 sliding panels on 2, 3, or 4 tracks.
- Sliding panels can be markerboards, tackboards, or a combination of both.
- Sizes available up to 4'H x 16'W.

HORIZONTAL SLIDING UNITS

PRODUCT OPTIONS

Recessed Slider

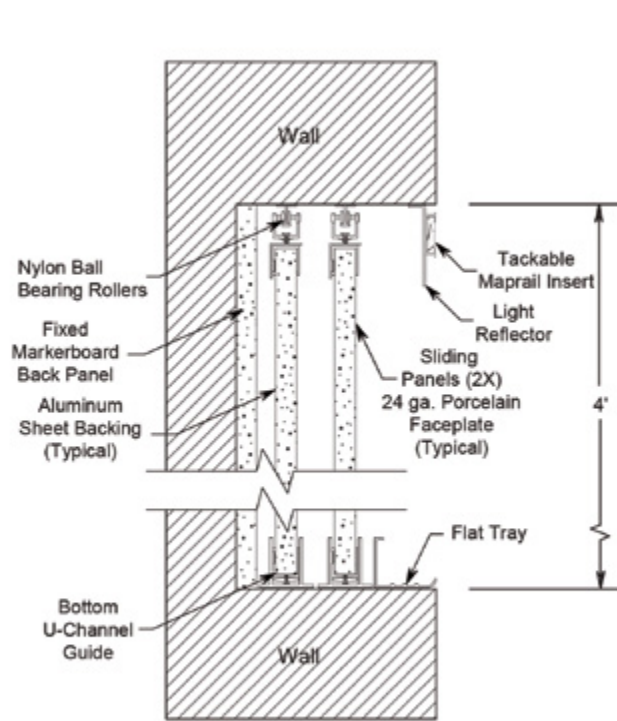

Surface Mounted Slider

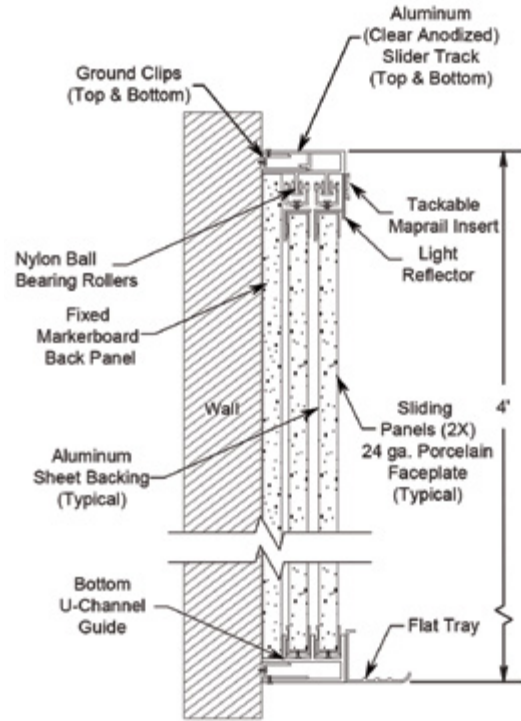

BULLETIN BOARDS

▶ **AJW Bulletin Boards** are another communication tool that provide you with the opportunity to share your news in the boardroom, school hallway, or building reception area. Choose from one of our standard bulletin board cabinets or have us design a custom unit that conforms to your specific project's requirements.



▶ BULLETIN BOARD SPECIFICATIONS

- Surface mounted and recessed options available. Surface mounted units installed with Z-bar hangers.
- Heavy gauge extruded aluminum housing, with standard clear anodized finish.
- Powder coating options available. (See color chart on page 5)
- Tackable back panel available in natural cork, colored cork, designer fabric, Type I or Type II vinyl.
- 1/4" thick tempered safety glass. Sliding and hinged type doors available.
- Hinged door bulletin boards have continuous piano hinges and are equipped with keyed tumbler locks.
- Sliding door bulletin boards are equipped with keyed sliding ratchet locks.

▶ STANDARD SIZES

2'H x 3'W

2'H x 4'W

3'H x 3'W

3'H x 4'W

3'H x 5'W

3'H x 6'W

4'H x 4'W

4'H x 5'W

4'H x 6'W

CONFERENCE UNITS

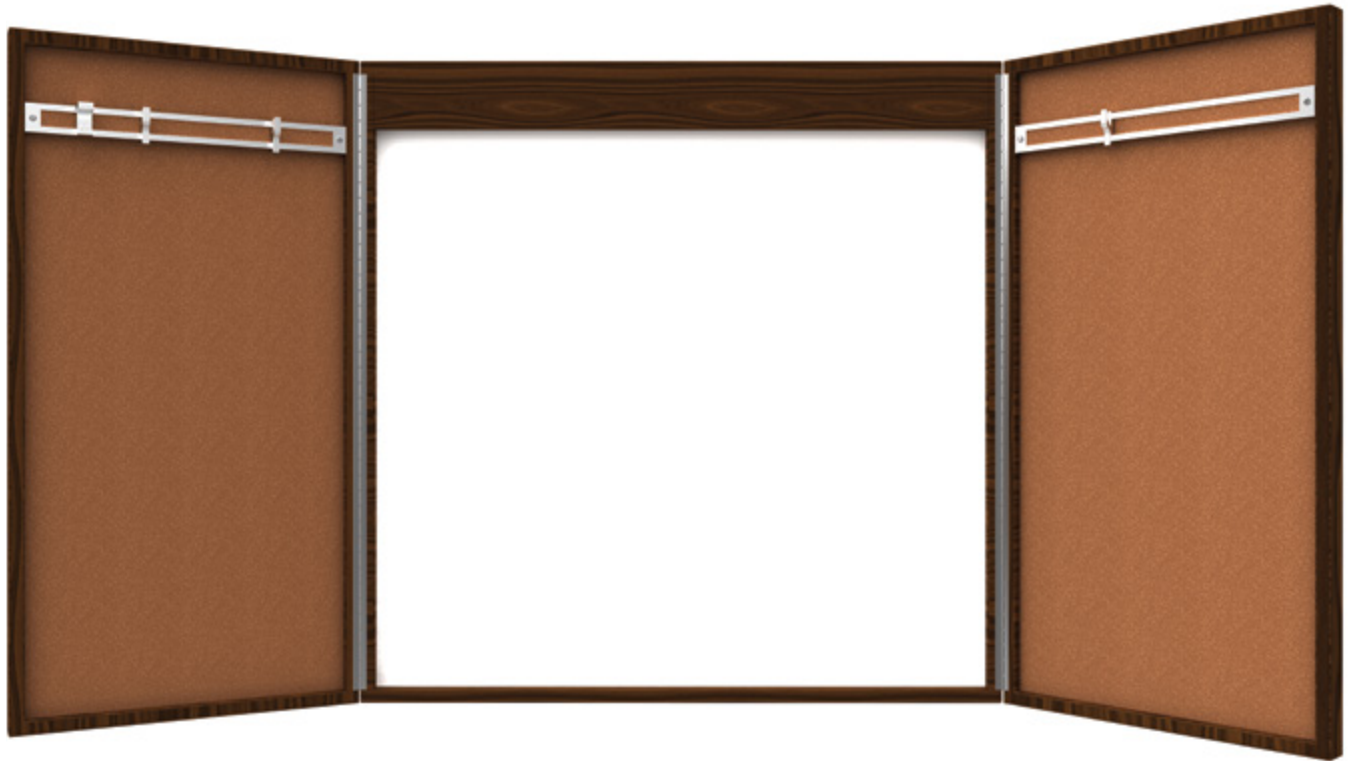

- ▶ **AJW Conference Units** are practical and elegant. A classic wood finish will complement the decor of your boardroom, meeting room, or office. Our conference units feature a high quality porcelain on steel writing surface with tackable panels inside the doors.

▶ CONFERENCE UNIT SPECIFICATIONS

- Balanced, high pressure laminated, porcelain enamel markerboard of three-ply construction consisting of face sheet, core material, and backing.
- Choose from any one of AJW's tackable surfaces.
(Natural Cork, Colored Cork, Vinyl Faced, Fabric Faced)
- Available in any of AJW's standard laminate colors.

GLASS MARKERBOARDS

Mounting Options

Concealed Z-Bracket



Standoff Mounting

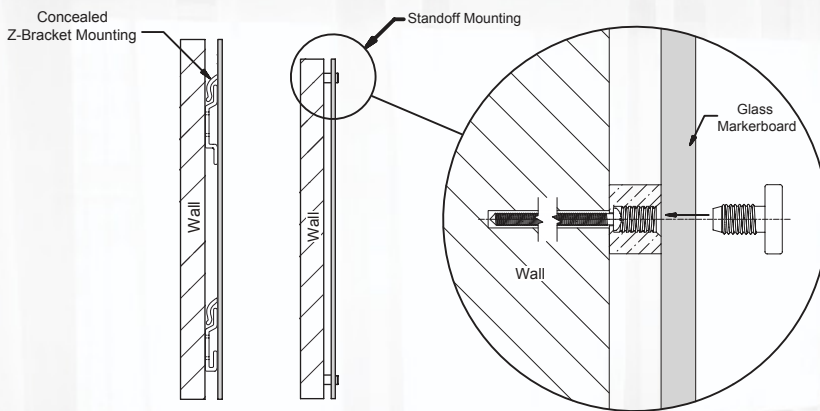

Custom Color Options



AJW CUSTOM GLASSBOARDS

Looking to add a designer's edge to your classroom, boardroom, or your results driven environment? AJW Glass Markerboards have an attractive finish, and are available in endless color options. AJW will help you design your customized board to fit your application or choose from one of our standard installer-friendly mounting options.

- Available in two standard mounting styles (Standoff and Concealed Mounting).
- Custom Sizes Available: 4'H x 10'W maximum in one piece.
- Custom colors available.
- Customize your board with your company logo, school name, or your design of choice.

GLASS MARKERBOARDS

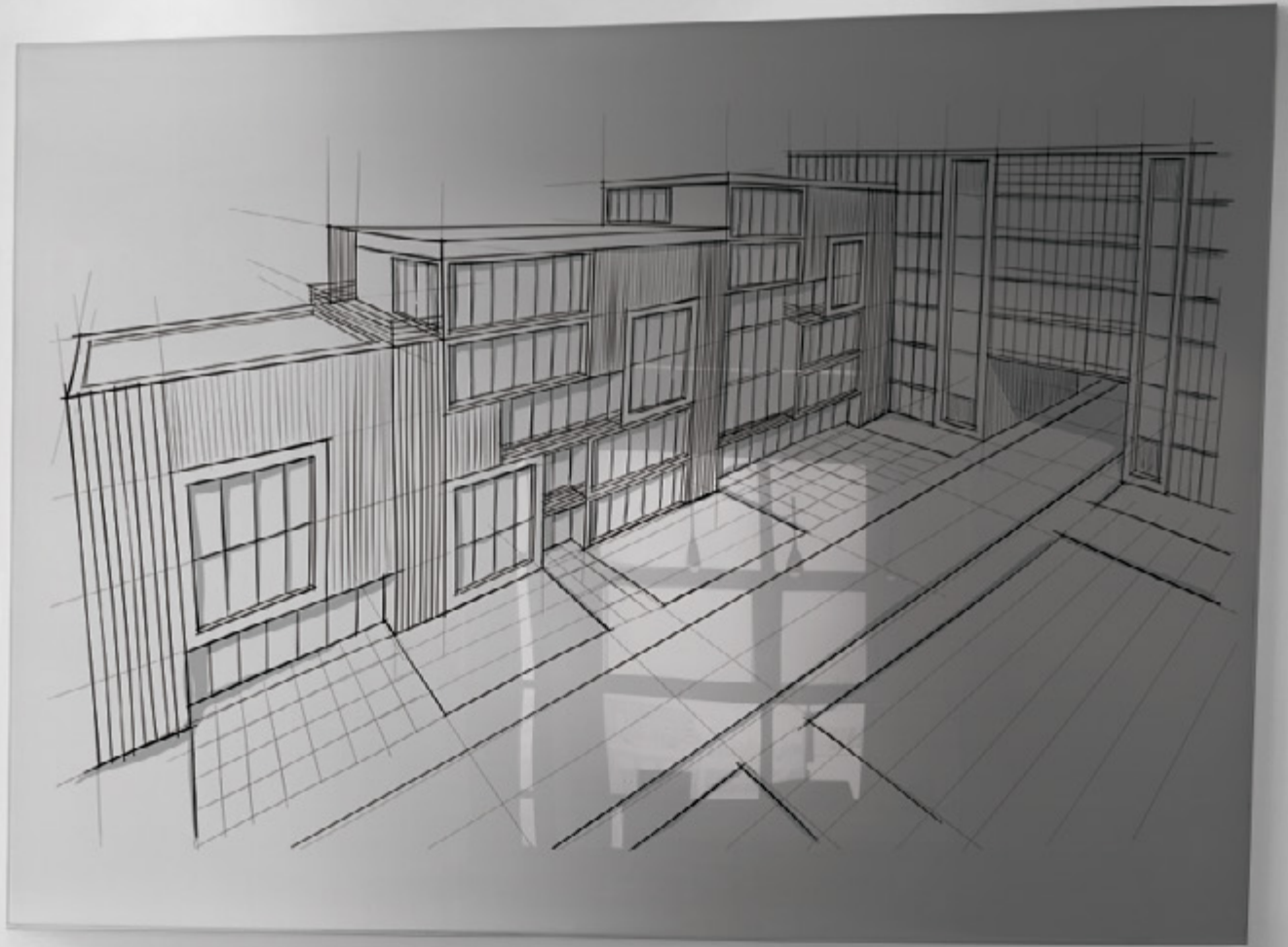



- Mirrors & Shelves
- Grab Bars
- Hand Dryers
- Towel Dispensers
- Custom Accessories

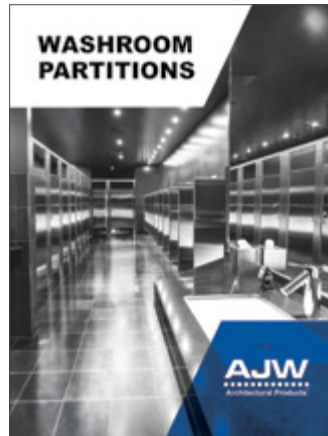

- Solid Plastic Partitions
- Stainless Steel Partitions
- Baked Enamel Partitions
- Phenolic Black Core Partitions
- Plastic Laminate Partitions



- Standard Series Lockers
- Professional Series Lockers
- Athletic Series Lockers
- TA-50 Series Lockers
- Benches



Volume 1

509 Temple Hill Road
New Windsor, NY 12553-5532

Phone (845) 562-3332

Fax (845) 562-3391

www.ajw.com

SECTION 10 1100

VISUAL DISPLAY UNITS

This section includes editing notes to assist the user in editing the section to suit project requirements. These notes are included as hidden text, and can be revealed or hidden by one of the following methods:

Microsoft Word 2010: Display the FILE tab on the ribbon, click OPTIONS, then on left menu click on DISPLAY. Under ALWAYS SHOW THESE select or deselect HIDDEN TEXT.

Microsoft Word 2007: Click the OFFICE button, select WORD OPTIONS, select Display, then select or deselect the HIDDEN TEXT option.

Corel WordPerfect: From the pull-down menus select VIEW, then select or deselect the HIDDEN TEXT option.

This master specification section has been prepared by AJW Architectural Products for use in the preparation of a project specification section covering markerboards, tackboards, sliding marker boards, bulletin boards, and display cases.

This specification is a part of the SpexPlus™ system, which comprises a full architectural master specification that can be used to specify all project requirements.

Other guide specifications are available from AJW covering the following products:

Section 10 2114 - Stainless Steel Toilet Compartments
Section 10 2116 - Solid Plastic Toilet Compartments
Section 10 2813 - Toilet Accessories
Section 10 5113 - Metal Lockers

The following should be noted in using this specification:

Hypertext links to specific websites are included after manufacturer names and names of organizations whose standards are referenced within the text, to assist in product selection and further research. Hypertext links are contained in parenthesis and shown in blue, e.g.:

(www.spexplus.net)

Optional text requiring a selection by the user is enclosed within brackets, e.g.: "Section [09 0000.] [____.]"

Items requiring user input are enclosed within brackets, e.g.: "Section [____ - ____]."

Optional paragraphs are separated by an "OR" statement, e.g.:

*** OR ***

Sustainable requirements are included for projects requiring LEED certification, and are included as green text. For additional information on LEED, visit the U.S. Green Building Council website at www.usgbc.org.

For assistance on the use of the products in this section, contact AJW Architectural Products by calling 845-562-3332, email at specs@ajw.com, or visit their website at www.ajw.com.

For assistance with obtaining or using the SpexPlus™ Master Specification System contact SpexPlus by calling 1-888-877-SPEX (1-888-877-7739), by email at chaney@spexplus.net, or visit our website at www.spexplus.net.

PART 1 GENERAL

1.1 SUMMARY

Edit the following paragraphs to include only those items specified in this section.

- A. Section Includes:
 - 1. Markerboards.
 - 2. Tackboards.
 - 3. Horizontal sliding units.
 - 4. Display cases.
 - 5. Bulletin boards.

Coordinate the following paragraphs with other sections in the project manual.

- B. Related Sections:
 - 1. Division 01: Administrative, procedural, and temporary work requirements.

1.2 REFERENCES

In the following paragraphs, retain only those reference standards that are used elsewhere in this section.

- A. ASTM International (ASTM) (www.astm.org):
 - 1. B221 - Standard Specification for Aluminum and Aluminum-Alloy Extruded Bars, Rods, Wire, Profiles, and Tubes.
 - 2. E84 - Standard Test Method for Surface Burning Characteristics for Building Materials.
- B. Federal Specifications (FS) CCC-W-408D - Wall Covering, Vinyl Coated.

1.3 SUBMITTALS

Limiting submittals to only those actually required helps to minimize liability arising from the review of submittals. Minimize submittals on smaller, less complex projects.

Include the following for submission of shop drawings, product data, and samples for the Architect's review.

- A. Submittals for Review:
 - 1. Shop Drawings: Illustrate each visual display unit required; include dimensioned elevations of each display board; show anchors and accessories.
 - 2. Product Data: Descriptive data on display boards, including [markerboard] [and] [tackboard] surface, frame, trim, and accessories.
 - 3. Samples: Provide samples illustrating face, core, backing, and trim material showing colors and textures.

Include the following for submission of sustainable design submittals.

- B. Sustainable Design Submittals:
 - 1. Regional Materials: Certify distance between manufacturer and project and between manufacturer and extraction or harvest point in miles.
- C. Closeout Submittals:
 - 1. Maintenance Instructions: Include cleaning and stain removal procedures and precautions.

1.4 QUALITY ASSURANCE

Coordinate the following with building code requirements; edit to suit project requirements.

- A. Tackboards: Maximum flame spread/smoke developed rating as required by Code, tested to ASTM E84.

1.5 DELIVERY, STORAGE AND HANDLING

- A. Provide factory-installed protective covering for markerboards; do not remove until after installation.

- B. Store products upright in manner providing proper protection.

1.6 WARRANTIES

- A. Markerboards: Provide manufacturer's life of original installation warranty providing coverage against loss of original writing or erasing capabilities, crazing, cracking, flaking, and staining.

PART 2 PRODUCTS

2.1 MANUFACTURERS

- A. Contract Documents are based on products by AJW Architectural Products, 509 Temple Hill Road, New Windsor, NY 12553, 845-562-3332, www.ajw.com, specs@ajw.com.

Edit the following to indicate whether or not substitutions will be permitted for the products in this section.

- B. Substitutions: [Under provisions of Division 01.] [Not permitted.]

2.2 MARKERBOARDS

- A. Markerboards:
 1. Balanced, high-pressure laminated, porcelain enamel markerboards, three ply construction consisting of face sheet, core material, and backing.
 2. Face sheet: Enameling grade cold-rolled steel specially processed for temperatures used in coating porcelain on steel. Coat faces and exposed edges with three coat process consisting of primer, ground coat, and color cover coat.

Edit the following to indicate desired type of core material.

3. Core material: 1/2 inch thick [particleboard, ANSI A208.1, Grade 1-M-1.] [Hardboard.]
4. Backing sheet: Manufacturer's standard aluminum foil sheet.
5. Laminating adhesive: Manufacturer's standard moisture resistant thermoplastic adhesive.

2.3 TACKBOARDS

Include the following for natural cork tackboards.

- A. Natural Cork Tackboards:
 1. Balanced, high pressure laminated, natural cork tackboards, two ply construction consisting of natural cork face sheet and backing.

Edit the following to indicate desired cork thickness.

2. Face sheet: [1/8] [1/4] inch thick self-healing natural cork sheet.

Edit the following to indicate desired backing sheet.

3. Backing sheet: [1/4 inch thick hardboard.] [3/8 inch thick fiberboard.]
4. Laminating adhesive: Manufacturer's standard moisture resistant thermoplastic adhesive.

Include the following for vinyl-fabric-faced cork tackboards.

- B. Vinyl Fabric-Faced Cork Tackboards:
 1. Balanced, high-pressure laminated, vinyl fabric-faced cork tackboards, three ply construction consisting of vinyl fabric face sheet, cork sheet core material, and backing.
 2. Vinyl fabric face Sheet: Mildew-resistant, washable vinyl fabric complying with FS CCC-W-408D, weighing minimum 13 ounces per square yard.

Edit the following to indicate desired cork thickness.

3. Cork sheet: [1/8] [1/4] inch thick self-healing natural cork sheet.

Edit the following to indicate desired backing sheet.

4. Backing sheet: [1/4 inch thick hardboard.] [3/8 inch thick fiberboard.]
5. Laminating adhesive: Manufacturer's standard moisture resistant thermoplastic adhesive.

Include the following for colored cork tackboards.

- C. Colored Cork Tackboards:
 1. Balanced, high-pressure laminated, colored cork tackboards, two ply construction consisting of colored cork face sheet material, and backing.
 2. Face Sheet: Seamless, 1/4 inch thick, self-healing ground natural cork compressed with resinous binder with washable vinyl finish and integral color throughout, laminated to burlap backing.
 3. Backing sheet: 1/4 inch thick hardboard.
 4. Laminating adhesive: Manufacturer's standard moisture resistant thermoplastic adhesive.

2.4 ALUMINUM TRIM AND ACCESSORIES

- A. Aluminum Trim:
 1. Fabricate from minimum 0.062 inch thick extruded aluminum alloy of proper size and shape to suit installation.
 - a. Minimize joints.
 - b. Miter corners to neat, hairline closure.
 2. Frame markerboards and tackboards with [3/4 inch flat trim.] [1-1/2 inch box trim.] [1-1/4 inch wide flat trim.]
- B. Marker Tray: Manufacturer's standard continuous, [solid type aluminum tray with ribbed section.] [box type aluminum tray with slanted front and cast aluminum end closures.]
- C. Map Rail:
 1. Rail: Continuous cork display rail [1 inch] [2 inches] wide, integral with map rail.
 2. End stops: One end stop each at each end map rail.
 3. Map hooks: Two map hooks with flexible metal clips for each 48 inches of map rail.
 4. Flag holder: One flag holder for each map rail.

2.5 HORIZONTAL SLIDING UNITS

- A. Horizontal Sliding Units:
 1. Trim and panel edging fabricated from heavy gauge extruded aluminum.
 2. Mount nylon ball bearing rollers on top of each sliding panel.
- B. Mounting Style: [Surface mounted.] [Recessed.]
- C. Back Panel: [Porcelain enamel markerboard.] [Natural cork tackboard.] [Colored cork tackboard.] [Vinyl faced tackboard.] [None.]

Edit the following to indicate desired number of sliding panels.

- D. Number of Sliding Panels: [Two.] [Three.] [Four.]

Edit the following to indicate desired number of tracks.

- E. Number of Tracks: [Two.] [Three.] [Four.]
- F. Sliding Panel Material: [Porcelain enamel markerboard.] [Natural cork tackboard.] [Colored cork

tackboard.] [Vinyl faced tackboard.]

2.6 DISPLAY CASES

A. Recessed Display Cases:

Edit the following to indicate desired back panel type.

1. Back panel: [Natural cork tackboard.] [Colored cork tackboard.] [Vinyl faced tackboard.] [Wood veneer.]

Edit the following to indicate desired box type.

2. Wood box: [Wood veneer, low pressure laminate material, as side panels for display case.] [None.]

Edit the following to indicate desired trim type.

3. Aluminum trim: Heavy gauge extruded aluminum, [1 inch] [2 inches] [3 inches] wide.

Edit the following to indicate desired door type.

4. Doors: 3/16 inch thick tempered safety glass, [sliding] [hinged] type.
5. Shelving: Three adjustable glass shelves with brackets for attachment to vertical standards.

In the following paragraph select sliding ratchet type for sliding doors and tumbler type for hinged doors.

6. Lock: [Sliding ratchet] [Tumbler] type.

Include the following for optional lighting.

7. Lighting: Top mounted fluorescent strip lighting fixtures.

B. Surface Mounted Display Cases:

1. Housing: 1.5 x 2 inch extruded aluminum tubing.

Edit the following to indicate desired back panel type.

2. Back panel: [Natural cork tackboard.] [Colored cork tackboard.] [Vinyl faced tackboard.] [Wood veneer.]

Edit the following to indicate desired door type.

3. Doors: 3/16 inch thick tempered safety glass, [sliding] [hinged] type.
4. Shelving: Three adjustable glass shelves with brackets for attachment to vertical standards.
5. Lock: Sliding ratchet type.

Include the following for optional lighting.

6. Lighting: Top mounted fluorescent strip lighting fixtures.

2.7 BULLETIN BOARDS

A. Aluminum Framed Bulletin Boards:

1. Back panel: [Natural cork tackboard.] [Colored cork tackboard.] [Vinyl faced tackboard.]
2. Housing: 3 inch extruded aluminum.

Edit the following to indicate desired door type.

3. Doors: 3/16 inch thick tempered safety glass, [sliding] [hinged] type.
4. Lock: Sliding ratchet type.

2.8 ACCESSORIES

- A. Fasteners: Type best suited to application; head finish to match frame where exposed.

2.9 FABRICATION

- A. Markerboards: Laminate face and backing sheets to core material under pressure with each substrate having minimum 80 percent coverage with 1.5 to 2.0 dry mils of laminating adhesive.
- B. Factory assemble units.

2.10 FINISHES

Include the following for porcelain enamel marker board; edit to indicate desired writing surface.

- A. Markerboards: Medium gloss white finish suitable for use with erasable dry markers.

Include the following for vinyl fabric-faced cork tackboards; edit to indicate desired color.

- B. Vinyl Fabric: [] color [to be selected from manufacturer's full color range].

Include the following for colored cork tackboards; edit to indicate desired color.

- C. Colored Cork: [] color [to be selected from manufacturer's full color range].
- D. Aluminum Frame and Trim: Clear satin anodized.

PART 3 EXECUTION

3.1 INSTALLATION

- A. Install visual display boards in accordance with manufacturer's instructions.
- B. Set plumb and level, with perimeter trim straight.
- C. Secure with concealed fasteners.

Retain the following for illuminated display cases.

- D. Connect lighting to power supply.

3.2 CLEANING

- A. Remove temporary protective coverings.
- B. Clean surfaces in accordance with manufacturer's instructions.

END OF SECTION

Tackboard Colors - Colored Cork



Desert Sand (2067)



Grey (2162)



Tan (2166)



Stone (2182)



Blue (2185)



Buff (2186)



Fawn (2187)



Red (2201)



Black (2202)



Green (2203)



Graphite (2204)



Midnight Blue (2205)

Note: Color charts are printed approximations--actual colors may vary. Please contact AJW to request a sample.



N21F-0C Series
 Tackboard, Hardboard Core, Flat Trim,
 No Tray, No Maprail, Colored Cork

Job #:
Item #:
Quantity #:

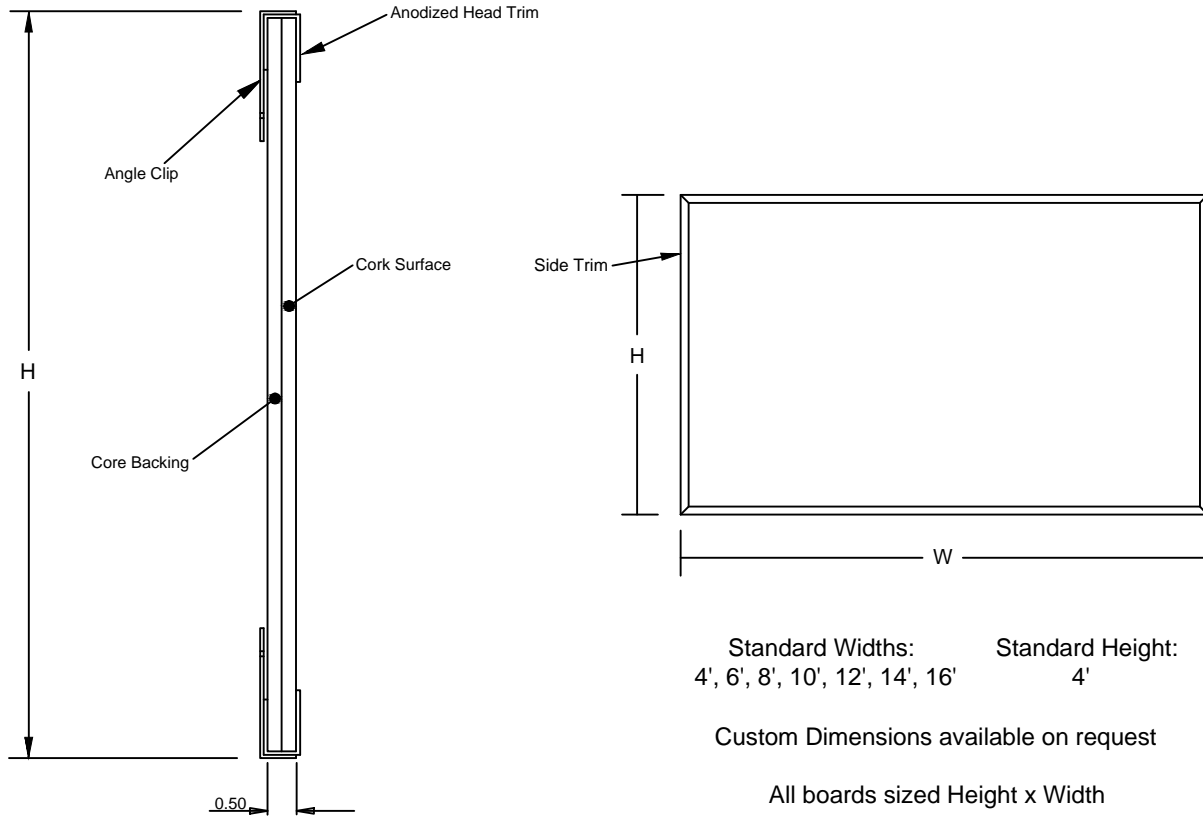

Drawing is for assembly description only.
 Components are not to scale for clarity purposes.

- Core Backing:** 1/4" Hardboard.
- Tackable Surface:** 1/4" Colored Cork.
- Trim:** 3/4" Flat Trim - Anodized Aluminum.
- Tray:** None.
- Maprail:** None.
- Tackable Maprail Insert:** N/A.

• All aluminum extrusions have a minimum thickness of 0.062"



N6-1N Series
Display Rail, 1" Tackstrip,
Natural Cork

Job #:

Item #:

Quantity #:

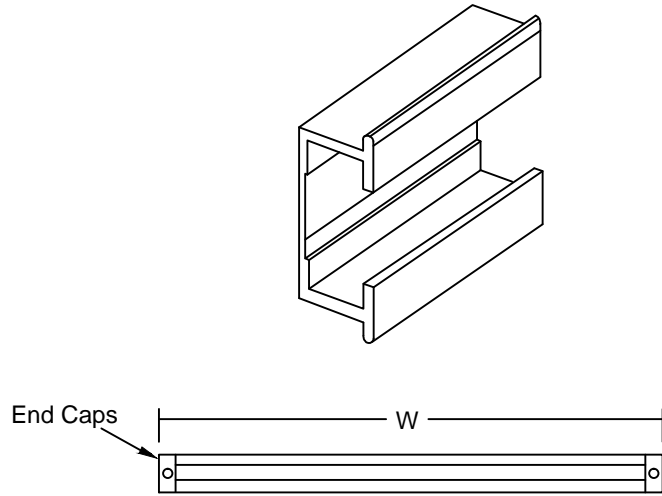
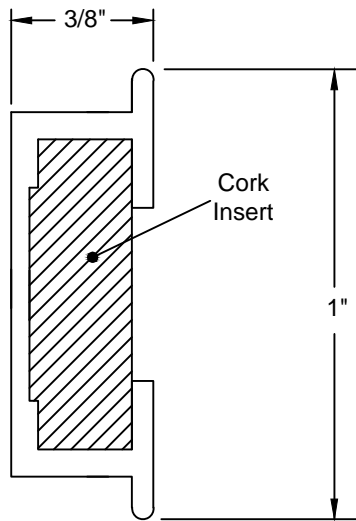

Standard Widths:
4', 6', 8', 10', 12', 14', 16'

Custom Widths available on request

Drawing is for assembly description only.
Components are not to scale for clarity purposes.

Size: 1"

Finish: Anodized Aluminum.

Tackable Maprail Insert: 1/4" Natural Cork.

• All aluminum extrusions have a minimum thickness of 0.062"