

date  
projectname  
attn  
from  
fax  
email  
phone

7/15/19  
omfe  
Tolulope  
tolu  
tolu.dayo14@gmail.com  
3016934015



## LEED Credit Information – Washroom Accessories

As intimidating as LEED certification may seem, we know that a little extra help goes a long way. That's why the AJW collection includes various products that can help you come closer to earning your LEED certification. While LEED doesn't certify products, using recycled, sustainable, and energy-efficient products earns you points in the LEED program.

The LEED credit information for AJW Washroom Accessories is as follows:

- **Sourced Material:** Stainless steel sourced within a 500 mile radius. Our stainless steel products will help with your eligibility toward MR Credits 5.1 and 5.2 if your project is within 500 miles of our manufacturing facility in New Windsor, NY and the original source, Pittsburgh, PA.
- **Raw material:** All AJW stainless steel products are made up of between 55% and 65% recycled material. 35% of our stainless steel is recycled pre-consumer and 25% is recycled post-consumer. Our stainless steel will help with your eligibility toward MR Credits 4.1 and 4.2.
- **Plastics:** All plastic AJW baby changing stations are made up of 50% recycled polyethylene, and AJW HD plastic retractable shower seat decks are made of 35% pre-consumer recycled polymers. Our plastic materials will help with your eligibility toward MR Credits 4.1 and 4.2.
- **Packaging:** Our corrugated cardboard packaging is made up of 87% post-consumer recycled material.
- **Glass:** All glass used in AJW mirrors are made up of 20% pre-consumer recycled materials.



**U582**  
 Surface Mounted Sanitary Napkin  
 Disposal  
 Revision 03/11

JOB #:  
 ITEM #:  
 QUANTITY:

MOUNTING	HANDING	TYPE	SIZE	OTHER

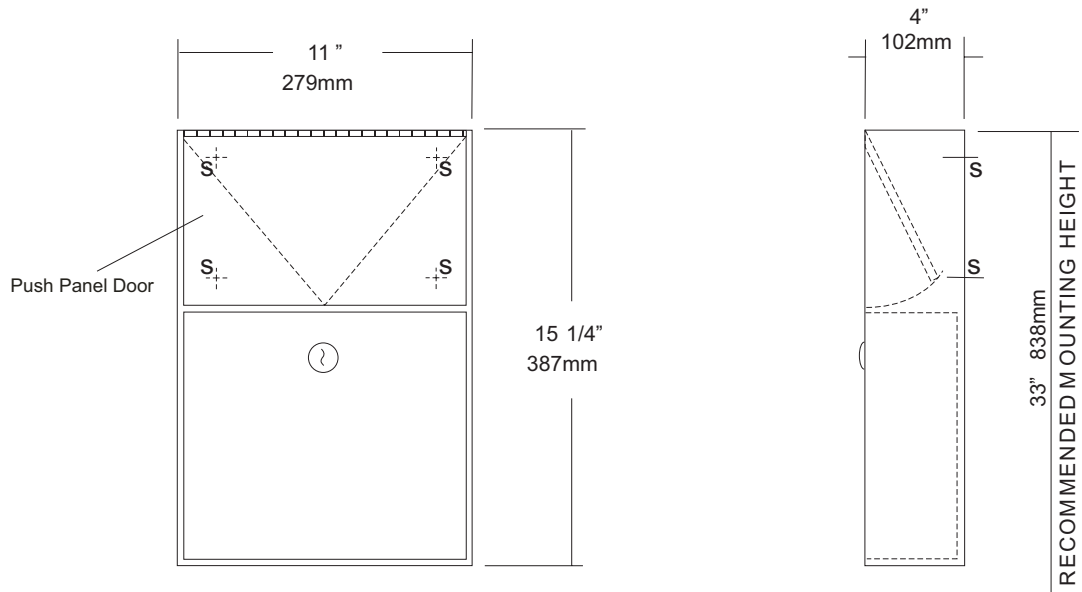

**SPECIFICATIONS** **INSTALLATION**

**Cabinet Body:** Fabricated of #22 ga stainless steel #4 satin finish,  
**Push Panel:** Fabricated of #22 ga stainless steel self closing push panel. International graphic symbols are optional.  
**Waste:** #22 ga stainless steel removable type waste secured by a pin tumbler lock. Optional finger grip in lieu of lock is available.  
**Locks:** Pin tumbler commercial quality locks keyed like all other AJW cabinets,  
**Hinge:** Full length, heavy duty, stainless steel piano type hinge,  
**Overall Size:** 11"W x 15 1/4"H x 4"D  
**279mm x 387mm x 102mm**  
**Capacity:** 1.5 gallons (.2 cu ft.)  
**NDL-13-50:** Waxed disposable liners. (50 per Case)  
**OPTIONS:**  
 -PW: Rigid plastic waste insert  
 -IGS: International Graphic Symbol

Provide an area on wall surface at desired or specified location. Place unit on wall and verify unit is level. Transfer mounting point locations and drill pilot holes. Remove waste can and secure to wall surface with proper fasteners for each application.

**NOTES**



## Warranty – Washroom Accessories

### Accessories

AJW guarantees its Washroom Accessories to be free of material defects, and defects from workmanship for a period of one (1) year from the date of shipment.

### Baby Changing Stations

AJW baby changing stations are guaranteed for five (5) years from the date of shipment.

### Mirrors

We guarantee our mirrors against silver spoilage for a period of fifteen (15) years under normal use. This guarantee includes all ¼” plate glass mirrors including tempered, laminated, and all other ¼” safety glass mirrors.

### Hand Dryers

Our Jet Air hand dryers are warranted to be free of defects from workmanship under normal use and maintenance for a period of five (5) years from date of shipment (with the exception of the U1511EA which has a warranty period of two (2) years from date of shipment). Hand dryer warranty info is as follows:

- U1511EA- 2 Year Limited Warranty, Motor Brushes 2 Years, Eye Sensor One Year
- U1512EA- 5 Year Limited Warranty, Motor Brushes 2 Years, Eye Sensor One Year
- U1521EA- 5 Year Limited Warranty, Eye Sensor One Year
- U1525EA- 5 Year Limited Warranty, Eye Sensor One Year

**This warranty excludes defects in the Washroom Accessory caused by: vandalism, improper use, improper installation, neglect, and environmental damage.**

**If the Washroom Accessory is found to be defective in workmanship or materials within the warranty period, AJW will replace all affected components, free of charge. AJW will not be responsible for any other expenses including, but not limited to: removal costs, installation costs, freight costs, or any other costs associated with the repair or replacement of the product.**

**The replacement or repair of defective material as stated in this warranty shall constitute the sole remedy of the buyer and the sole liability of AJW under this warranty. AJW shall not be liable for any incidental, consequential, or indirect damages caused by the failure or defect in the material supplied, or any delay in the replacement or repair of warranty items.**

**Warranty claims must be made during the warranty period, and communicated to AJW by contacting AJW Architectural Products at: 509 Temple Hill Road – New Windsor, NY 12553 – Phone: 845-562-3332.**