

date
projectname
attn
from
fax
email
phone

3/26/2019
submittals
Nicole

nicole@apsi-usa.com
5106862751



U1525EA Series

White Hands Free Dryer

Revision 12/14

JOB #:

ITEM #:

QUANTITY:

MOUNTING	HANDING	TYPE	SIZE	OTHER
----------	---------	------	------	-------

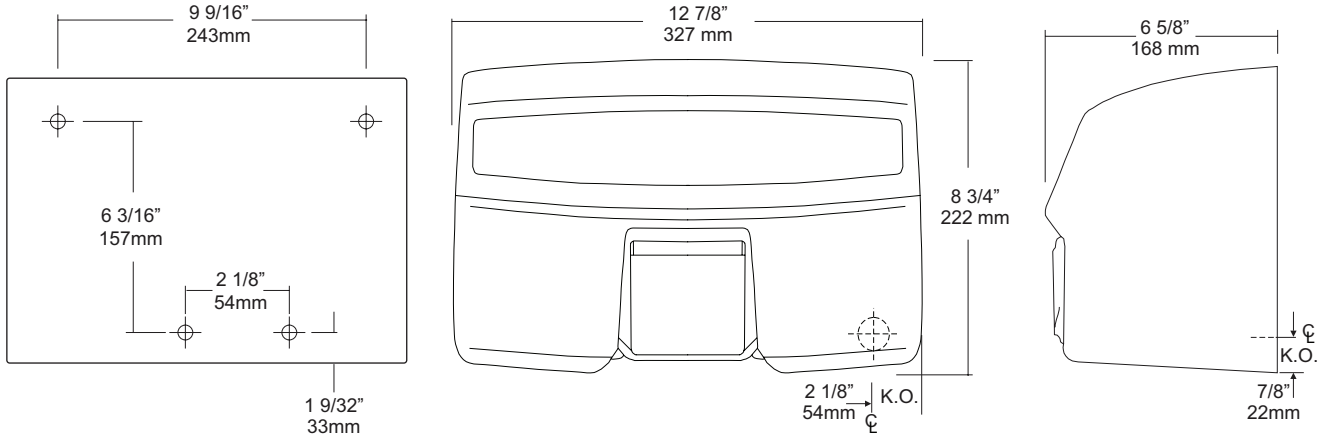

SPECIFICATIONS

Motor: Brushless 3450 RPM, 1/8 hp motor, capacitor initiated, thermally protected against overheating. 66.1 dB.

Fan: Dynamically balanced to eliminate vibration/noise.

Heating Element: 2300 watt nichrome wire, mounted on state of the art convective heating injection system mounted to blower housing, protected by integral safety circuit breaker.

Timer: Fully enclosed electronic timer that automatically turns off when hands are moved away from path of sensor.

Electric Eye: Sensor allows a hands free operation. When sensor beam path is disturbed, dryer will automatically turn on. When hands are moved away from beam, dryer stops.

Cover: Heavy die cast aluminum with baked white enamel finish and ribbed for added strength. Secured to base with two theft resistant fasteners. Chrome plated nozzle can be fixed or two position.

Base: One piece #14 ga steel with 3/4" returns to wall for maximum strength and rigidity.

Unit	Volts	Amps	Cycles
U1525EA	120V	110-120	20 60
U1525EA	230V	208-230	10 60

Overall Size: 12 7/8"W x 8 3/4"H x 6 5/8"D
327mm x 222mm x 168mm

INSTALLATION

Coordinate installation with contractor, architect and licensed electrician. Transfer mounting points to wall surface with supplied template. Check all code requirements for proper mounting heights. Secure base to surface with proper fasteners per application. Properly connect power supply to dryer and test operation. Secure dryer to base and test dryer again after cover is secured. Recommend 1 dryer per basin. Dryers have a full five (5) year warranty to original purchaser against defective materials and workmanship. Unit must be installed by a licensed electrician.

Mounting	Hands	Hair
Men	46" (1168mm)	73" (1854mm)
Women	44" (1118mm)	68" (1727mm)
Physically Impaired	38" (965mm)	46" (1168mm)
Children 6-10	34" (864mm)	43" (1092mm)
Children 11-14	42" (1067mm)	56" (1422mm)

*Above are recommended mounting heights from lower mounting point above the finished floor.

NOTES

Formerly Model #: U1525EA



U933

Retractable Shower Seat

Revision 1/14

JOB #:

ITEM #:

QUANTITY:

MOUNTING	HANDING	TYPE	SIZE	OTHER

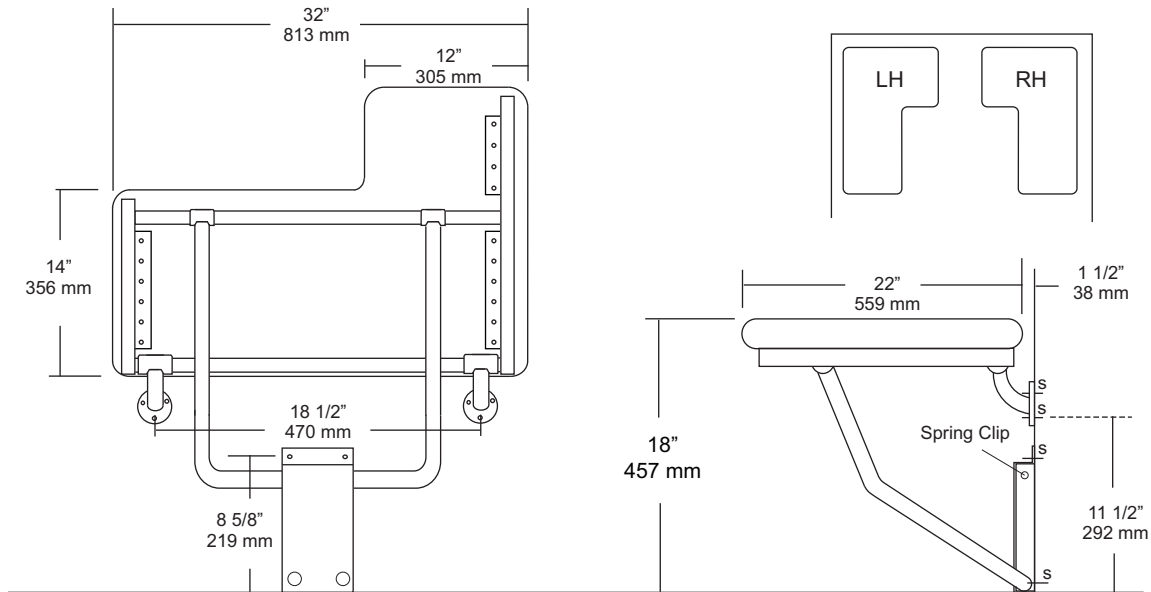

SPECIFICATIONS

Seat: Fabricated of 2 1/2" thick, water-resistant reinforced vinyl fabric cushion (white) seamless design with all leading edges having a radius. Seat is secured to a 1/2" thick marine plywood.

Tubing: Fabricated of #11 ga stainless steel with #4 satin finish.

Main Frame: #18 ga 1 1/4" with satin finish tubing. Underside has no exposed fasteners.

Flanges: #11 gauge stainless steel with four (4) exposed mounting points. Under slung supports have a 1 1/4" OD. (Satin finish)

Mounting Bracket: #16 ga stainless steel "hat" style bracket with 4 mounting support points. Bracket acts as a guide to raise and lower seat platform and is equipped with four (4) points to secure to wall surface. For maximum support, bracket is mounted so the bottom is set on the finished floor surface. Seat will remain in an upright position when not in use by means of a spring clip.

Overall Size: 32"W x 22"D (seating area)
813mm x 559mm
U933L: Left Handed
U933R: Right Handed

INSTALLATION

To comply with ADA Code, seat should be mounted at a height 17" - 19" above finished floor. Check all state and local codes for proper mounting requirements. Recommend in wall mounting on all shower seats. (BP10) Place seat up against wall making sure the extended part of seat has an offset no more than 1 1/2" away from wall. (Same as grab bar) Transfer mounting points to wall surface and drill pilot holes. Secure seat to surface with proper fasteners per each application. Snugly secure seat to surface and check seat to be level. If seat is level raise and lower seat to check path of travel. Finish securing seat after checking seat for proper operation. When properly mounted seat will support up to 250 lbs and will conform with ADA Code 4.21.3 and 4.26.3

Note: This shower seat is not intended to be installed in applications that have shower bases with rounded corners. AJW recommends the U928 for such applications.

NOTES

Formerly Model #: U933-1A



U936 Retractable Tub Seat

Revision 10/14

JOB #:

ITEM #:

QUANTITY:

MOUNTING	HANDING	TYPE	SIZE	OTHER

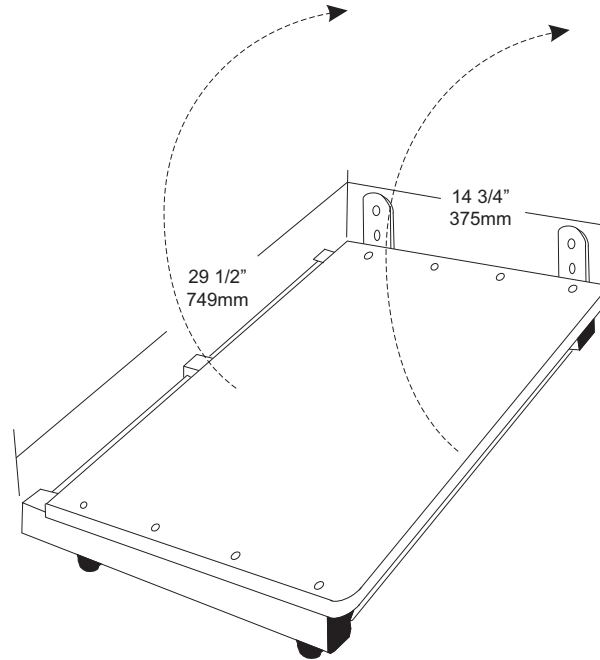

SPECIFICATIONS

Seat: Fabricated of 3/4" solid one piece, white HDP (High Density Plastic) with radius leading edges to prevent injury. Secured to frame by means of 1/4" stainless steel rivets. Seat material is warp / water resistant and will not support bacteria or fungi. There are no chemicals that may irritate human skin.

Frame: Fabricated of #18 gauge 1 1/4" stainless steel square tubing, #4 satin finish with capped ends. No exposed fasteners. 1" diameter stainless steel tubing (same material) cross tubing provides added strength and rigidity.

Mounting Supports: Square tubing (#18 ga) along with #11 gauge vertical mounting plated with exposed mounting points.

Anti Slip Supports: Frame is equipped with anti slip/ anti scratching devices.

Overall Size: 29 1/2"W x 14 3/4"D

749mm x 375mm

Seating Area: 28 1/2"W x 12 7/8"D

724mm x 327mm

INSTALLATION

Place tub seat on rim of tub. Make sure seat is square with corner of the tub area. Transfer mounting points to wall surface. Drill pilot holes for mounting. Secure tub seat with proper fasteners per application. When ever possible use concealed in wall backing (BP10 plates) added support.

When seat is not in use in the upright position, seat will pass the 90 degree point and rest against wall. When mounted properly space between seat and wall will be no greater than 1 1/2".

NOTES

JOB #:

ITEM #:

QUANTITY:

MOUNTING	HANDING	TYPE	SIZE	OTHER

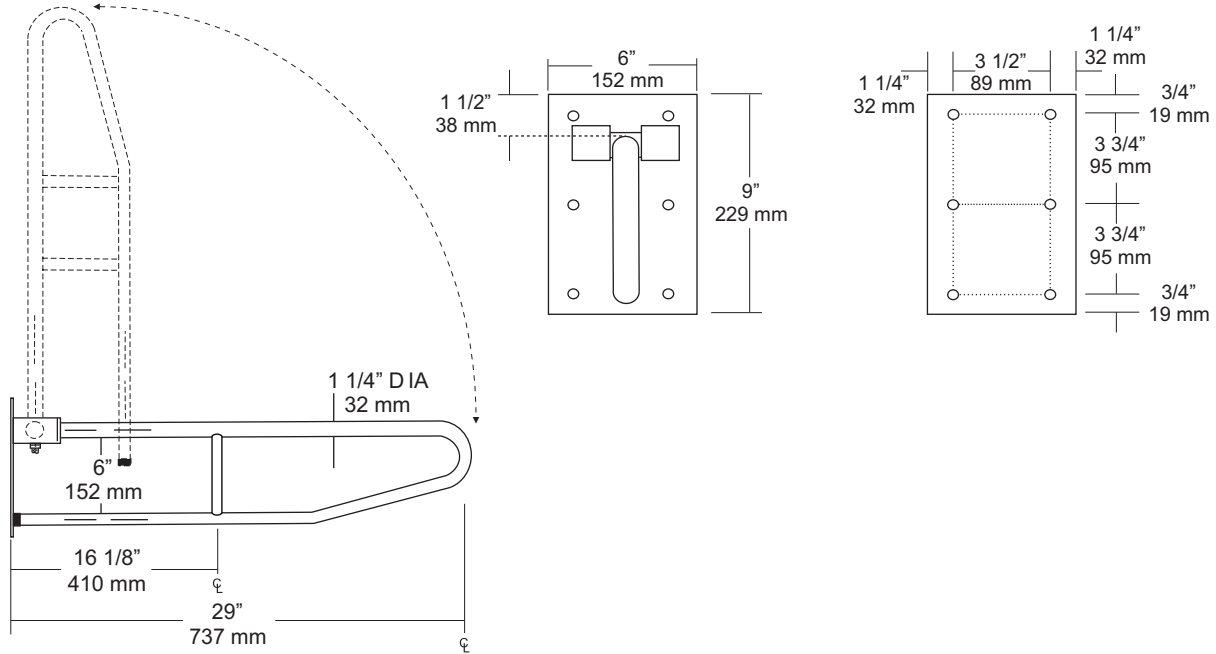

SPECIFICATIONS

Mounting Plate: Fabricated of #11 ga stainless steel, #4 satin finish with 6, 1/4" dia exposed mounting points.

Bar: #18 ga, 1 1/4" diameter, stainless steel with a #4 satin finish. All bends formed by an automatic mandrel bending process which maintains a uniform bar diameter around bends.

Gripping Surface: Standard surface is satin finish. Use suffix X for peened grip. (Anti-slip)

Intermediate Supports: Same material as bar with contour cuts that are heliarc welded.

Pivot Brackets: Dual supports fabricated of #18 ga square stainless steel tube with capped ends.

Tension Control Mechanism: An adjustable clutch to control the amount of tension on the bar required to raise and lower the bar. This prevents bar from falling when in the up-right position.

Check all state and local building codes for proper mounting heights and locations. ADA code specifies 33"-36" above finished floor for maximum mounting height.

When properly mounted, swing-up type bar will sustain a static load of 250 lbs.

Finish:

-PC: White Powder Coat

INSTALLATION

Installation: Coordinate installation with architect and contractor to avoid interference with toilet, stall doors, etc. Place unit on wall surface making sure unit is level, transfer mounting points and drill pilot holes. Secure unit with proper fasteners per application.

NOTES



UG120-W

Grab Bars With Toilet Tissue Holder

Revision 12/13

JOB #:

ITEM #:

QUANTITY:

MOUNTING	HANDING	TYPE	SIZE	OTHER

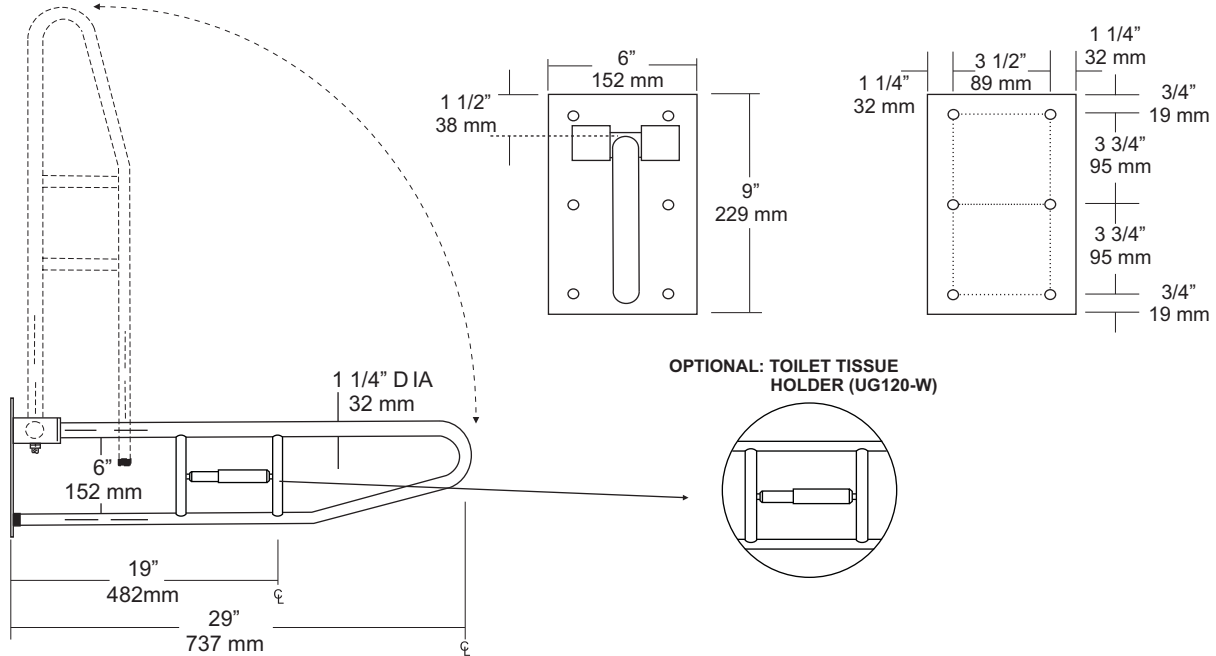

SPECIFICATIONS

Mounting Plate: Fabricated of #11 ga stainless steel, #4 satin finish with 6, 1/4" dia exposed mounting points.

Bar: #18 ga, 1 1/4" diameter, stainless steel with a #4 satin finish. All bends formed by an automatic mandrel bending process which maintains a uniform bar diameter around bends.

Gripping Surface: Standard surface is satin finish. Use suffix X for peened grip. (Anti-slip)

Intermediate Supports: Same material as bar with contour cuts that are heliarc welded. Intermediate supports designed to accommodate optional toilet tissue holder.

Pivot Brackets: Dual supports fabricated of #18 ga square stainless steel tube with capped ends.

Tension Control Mechanism: An adjustable clutch to control the amount of tension on the bar required to raise and lower the bar. This prevents bar from falling when in the up-right position.

Check all state and local building codes for proper mounting heights and locations. ADA code specifies 33"-36" above finished floor for maximum mounting height.

When properly mounted, swing-up type bar will sustain a static load of 250 lbs.

Finish:
-PC: White Powder Coat

INSTALLATION

Installation: Coordinate installation with architect and contractor to avoid interference with toilet, stall doors, etc. Place unit on wall surface making sure unit is level, transfer mounting points and drill pilot holes. Secure unit with proper fasteners per application.

NOTE: When possible is recommended to use BP-30 in wall back plates when mounting swing-up grab bars. Under the square tube is an adjustment pin that will control the tension on the raising and lowering of the bar. Adjust to proper tension and test the path of the bar.

NOTES

Formerly Model #: UG120-U-M