

date
projectname
attn
from
fax
email
phone

08/24/2022
Central Moloney
White Construction
Austin Watson

austin.watson@whmdoor.com
850-503-1091



U126 Soap Dispenser

Revision 11/14

JOB #:

ITEM #:

QUANTITY:

MOUNTING	HANDING	TYPE	SIZE	OTHER



SPECIFICATIONS

Soap Tank: Fabricated of #20 ga stainless steel, #4 satin finish, fully welded one-piece construction.

Valve: All purpose antibacterial soap valve cylinder, black molded plastic push style valve that takes less than 5 lbs of force and one hand to operate complies with barrier free guidelines when mounted at proper height.

Viewer: Clear plastic window allows a constant fluid level check.

Concealed Mounting Plate: Fabricated of heavy gauge stainless steel.

Filler Cap: Fabricated of stainless steel, hinged to allow easy servicing, secured with special key that creates a vandal resistant dispenser.

Overall Size: 4 3/4"W x 8 1/4"H x 3 3/4"D (wall to valve)

121mm x 210mm x 95mm

Capacity: 40 oz.

Recommend type soaps without chloric solutions for proper operation.

INSTALLATION

Provide an area on mounting surface at desired or specified location. Secure concealed mounting plate to wall surface with proper fasteners. Slide dispenser down over mounting plate and secure by means of set screw located inside tank. Fill unit with proper soap. Close lid and secure with special key. Test valve for proper operation.

*It is not recommended to mount any soap dispenser on mirrors

**For best performance, use pre-mixed low concentrate solutions. Dispensers should have periodic maintenance performed to insure the life dispenser. Rinse out globe and valve with warm water to avoid sludge buildup.

Preventative Maintenance: Each dispenser should be flushed out aprx. Every 30 days with warm water to prevent valve from clogging with old soap. Do not use abrasive cleaners to clean dispenser.

NOTES



U128PC

Vanity Mounted Soap Dispenser

Revision 04/11

JOB #:

ITEM #:

QUANTITY:

MOUNTING	HANDING	TYPE	SIZE	OTHER

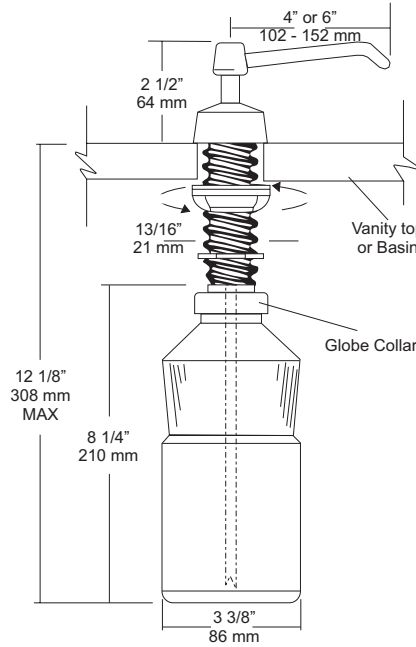

SPECIFICATIONS

Piston & Spout: Highly polished corrosion resistant, stainless steel. Assembly rotates 360 degrees.

Flange & Collar: One piece highly polished chrome on brass.

Valve Assembly: All purpose bellows valve, fabricated of ABS material, with stainless steel return spring.

Shank: Chrome on brass, secured to collar. Special key provided that unlocks collar for servicing.

Globe & Collar: High impact translucent polyethylene.

Capacity: 34 fl oz

U128PCA: Same as U128PC with 6" (152mm) spout.

Recommend type soaps without chloric solutions for proper operation.

***All vanity soap dispensers are designed to be serviced above the counter**

INSTALLATION

Provide a 7/8" - 1" diameter opening in vanity or basin. Insert shank through cut out and secure with supplied washers and wing nut. Connect supply tube with valve making sure notch end is at bottom. Secure globe and collar to shank. Fill globe above counter. Secure upper assembly to shank. Prime dispenser every time unit is serviced.

*It is not recommended to mount any soap dispenser on mirrors

**For best performance, use pre-mixed low concentrate solutions. Dispensers should have periodic maintenance performed to insure the life dispenser. Rinse out globe and valve with warm water to avoid sludge buildup.

Preventative Maintenance: Each dispenser should be flushed out aprx. Every 30 days with warm water to prevent valve from clogging with old soap. Do not use abrasive cleaners to clean dispenser.

NOTES

Formerly Model #: U128-PC



U466
Corner Waste Receptacle

Revision 03/11

JOB #:

ITEM #:

QUANTITY:

MOUNTING	HANDING	TYPE	SIZE	OTHER

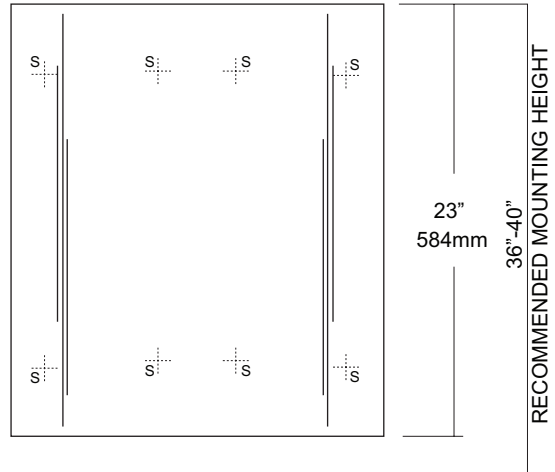
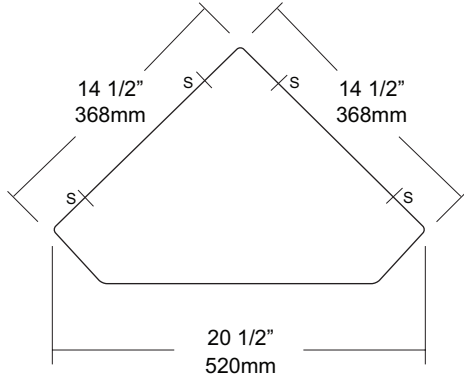

SPECIFICATIONS

Waste: Fabricated of #22 ga stainless steel with a #4 satin finish on all exposed surfaces. All leading edges are hemmed and have a radius to prevent injury.
Back: Fabricated of stainless steel formed for rigidity with multiple welds to cabinet body.
Overall Size: 20 1/2" W x 23"H x 14 1/2"
520mm x 584mm x 368mm
Waste Capacity: 13.5 gallons (1.8 cu ft)

INSTALLATION

Provide an area on wall surface at desired or specified location. Hold unit to wall surface, making sure unit is level and transfer mounting points. Drill pilot holes. Using proper fasteners per application, secure unit to wall surface.

NOTES



U6024

Uni-Door Folded Towel & Waste
Combination Unit

Revision 03/11

JOB #:

ITEM #:

QUANTITY:

MOUNTING	HANDING	TYPE	SIZE	OTHER

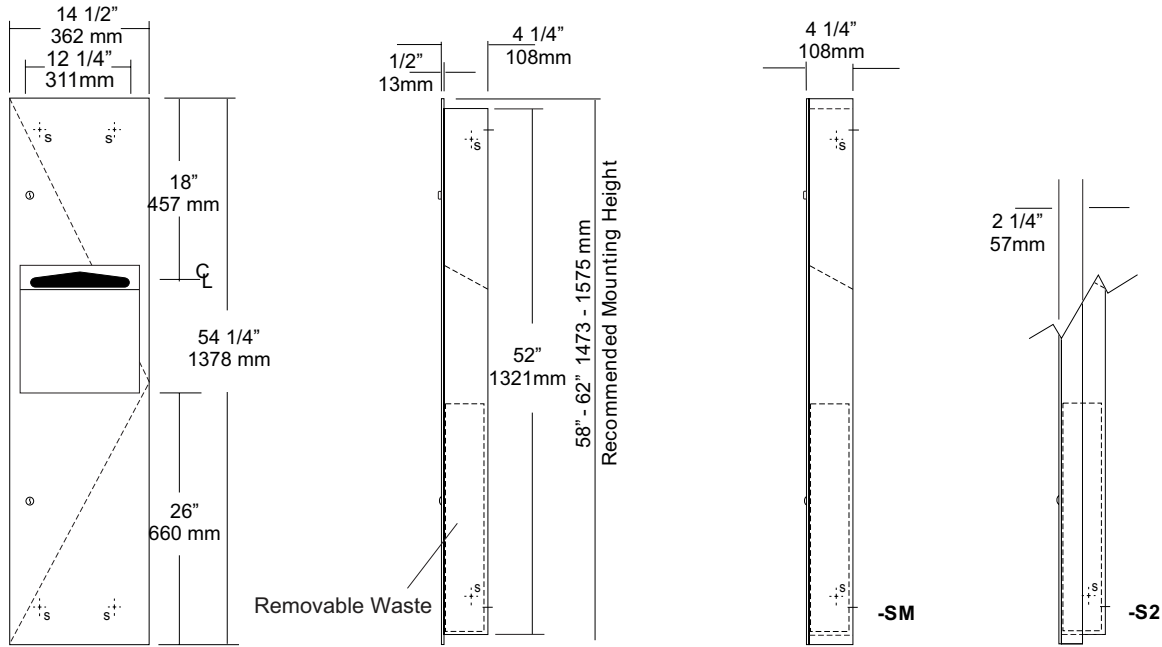

SPECIFICATIONS

Body: Fabricated of #22 ga stainless steel with a #4 satin finish.

Flange: Fabricated of #22 ga stainless steel with #4 satin finish and 1/4" returns to wall, no miters or welds.

Cabinet Back: Fabricated of stainless steel formed for rigidity with multiple welds to cabinet body.

Uni-Door: Fabricated of #18 ga stainless steel with #4 satin finish, one piece door with 1/2" returns.

Towel Dispenser: Dispensing area has hemmed edges to prevent injury and towel tearing.

Removable Waste: Removable waste, with heavy duty handle for easy removal.

Hinges: Heavy duty, full length, stainless steel piano type hinge.

Lock: Pin tumbler commercial quality keyed like all other AJW cabinets.

Collars: Fabricated of #22 ga #4 satin finish stainless steel finished to match cabinet body.

Overall Size: 14 1/2" W x 54 1/4"H x 4 1/4"D
368mm x 1378mm x 108mm

Wall Opening: 12 3/4"W x 52 1/2"H x 4"D
324mm x 1334mm x 102mm

U6024-S2: semi-recessed with 2" collar. (2" wall opening 51mm)

U6024-SM: Surface mounted with full skirt.

Towel Capacity: 600 c-fold or 800 multifold

Waste Capacity: 4 gallons (.53 cu ft)

INSTALLATION

Coordinate installation with contractor and architect to avoid interference with pipes vents etc. Provide a rough wall opening 12 3/4"W x 52 1/2"H. Wall opening depth will depend on style mounting. If a collar is required, slip over back of unit. Remove waste & install unit in opening. Make sure cabinet will sit flush in wall and secure with proper fasteners per application. Install waste back into cabinet and load paper towels.

When cleaning cabinet, use a soft cloth, a non-abrasive or chloric solutions.

NOTES

JOB #:

ITEM #:

QUANTITY:

MOUNTING	HANDING	TYPE	SIZE	OTHER

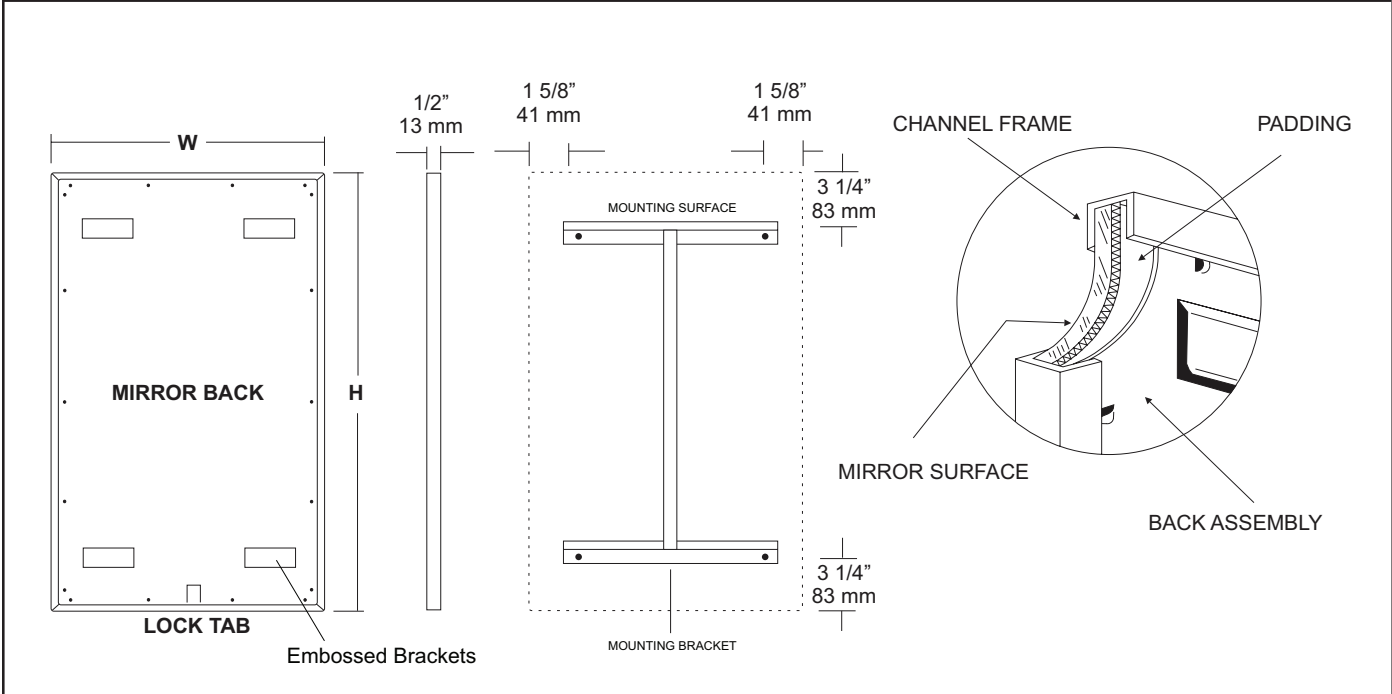

SPECIFICATIONS

Frame: Fabricated of #20 ga stainless steel, #4 satin finish. Roll formed 1/2" x 1/2" x 1/2" channel frame has mitered corners and secured with stainless steel rivet.

Mirror: 1/4" thick type 1 transparent flat type, class 1 - clear glass mirrors. Mirror is coated with silver and sealed with a uniform electrolytic copper plating, along with two coats of paint for added protection. Mirrors are guaranteed against silver spoilage for a period of 15 years. Mirrors conform to ASTM C1036 and ASTM C1503-R8.

Filler: Full size, 1/8" shock absorbing, water resistant, nonabrasive, polyethylene padding protects all concealed mirror surfaces.

Back: #20 ga pre-plated galvanized steel, with embossed horizontal louver mounting brackets. Embossed theft resistant pressure activated clip lock device, locks mirror in place to wall hangers.

Hangers: Fabricated of #20 ga pre-plated steel galvanized steel with mounting points.

Standard Sizes Available (W x H): 16"x20", 16"x24", 16"x30", 18"x24", 18"x30", 18"x36", 24"x30", 24"x36", 24"x42", 24"x48", 18"x60", 20"x60", 24"x60", 18"x72", 24"x72"

Options:

- LG:** Laminated Glass
- LX:** Polycarbonate
- PM:** Plastic Acrylic
- T:** Tempered Glass
- VC:** Vinyl Clad (Safety Glass)
- 8B:** #8 Reflective Stainless Steel

*Stainless steel mirrors reflect images in different optic quality than plate glass. There will be a slight distortion which increases proportionately with the mirror size. Therefore, AJW Architectural Products™ cannot be held responsible for quality of image.

- **Mirrors are always ordered Width x Height
- ***Recommended max size for 8B mirrors: 72" x 47-1/2"
- ****Framed mirrors are fabricated to a tolerance of (+/-) 1/8"
- ***** Mirrors conform to Federal Specifications DD-M-00411b & DD-g-541D

INSTALLATION

Coordinate installation with architect / contractor for specific mounting location and height for each mirror application. Making sure "I" bracket is level, transfer all mounting point locations to wall surface from drawing. Secure brackets with proper fasteners for each application. Slide mirror down over horizontal brackets until clip lock secures mirror in place. Mirror can only be removed by inserting tool through hole at bottom of frame depressing clip. This will allow mirror to slide up over brackets. Fillers are available if mirrors are mounted above and below tile line. (U004 Filler) filler material will match mirror frame to form a one piece construction.

To meet ADA Code, bottom edge of reflective surface can be no higher than 40" above finished floor. (4.19.6) Full length mirrors may be used for universal application when installed in correct locations.

Abrasive cleaners & chloric solutions should not be used on mirrors. Discoloring and /or scratching of frame and reflective surface may occur.

NOTES

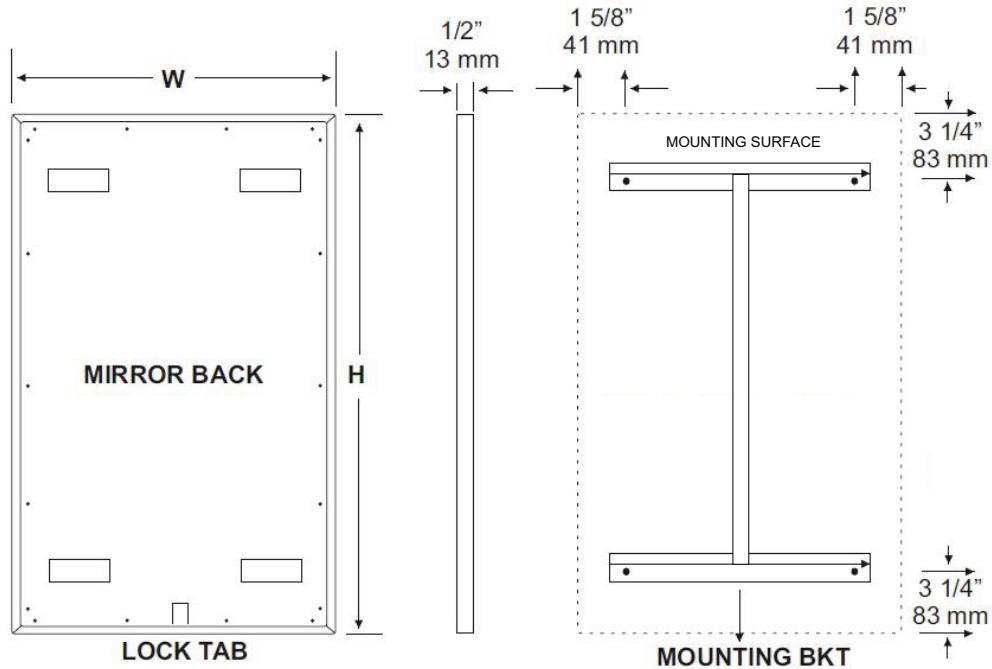

INSTALLATION

Coordinate installation with architect / contractor for specific mounting location and height for each mirror application. Making sure "I" bracket is level, transfer all mounting point locations to wall surface from drawing. Secure brackets with proper fasteners for each application. Slide mirror down over horizontal brackets until clip lock secures mirror in place. Mirror can only be removed by inserting tool through hole at bottom of frame depressing clip. This will allow mirror to slide up over brackets. Fillers are available if mirrors are mounted above and below tile line. (U004 Filler) Filler material will match mirror frame to form a one piece construction.

To meet ADA Code, bottom edge of reflective surface can be no higher than 40" above finished floor. (4.19.6) Full length mirrors may be used for universal application when installed in correct locations.

CARE & CLEANING

Wipe mirrors with a soft cloth, taking special care to rub stainless steel frames with the grain to avoid scratching. Do not use abrasive cleaners containing chloric solutions on stainless steel frames. Glass Plus or other window cleaning products are ideal.



U840 Toilet Tissue Dispenser

Revision 03/11

JOB #:

ITEM #:

QUANTITY:

MOUNTING	HANDING	TYPE	SIZE	OTHER

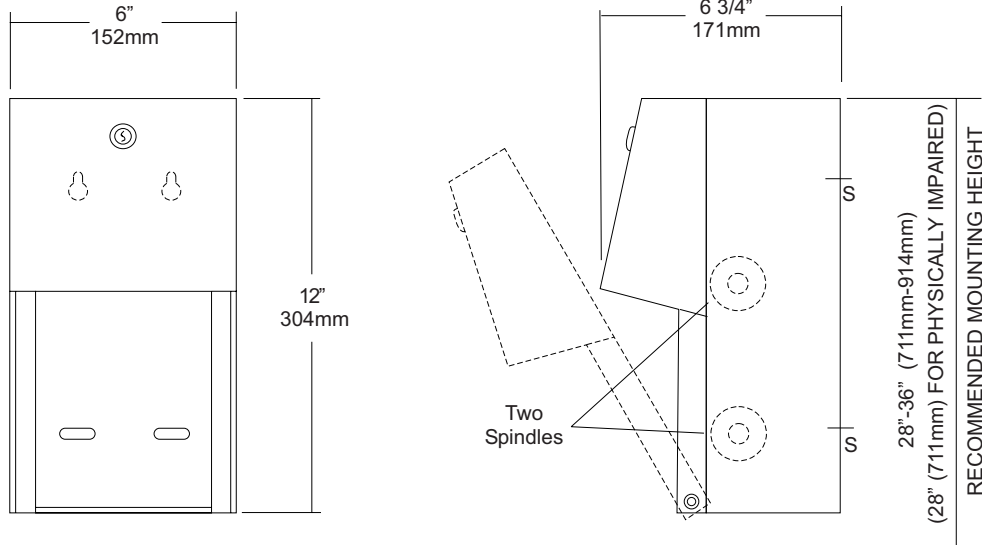

SPECIFICATIONS

- Body:** Fabricated of #22 ga stainless steel with #4 satin finish. Concealed inner dispensing mechanism is #18 ga stainless steel.
- Back:** Fabricated of #18 ga stainless steel with multiple welds to cabinet body forming a one piece construction.
- Hood:** Fabricated of #18 ga stainless steel finished to match cabinet body. Hood is secured with stainless steel hinge rivets to cabinet body. Top roll of tissue will not drop down unless the bottom roll has been depleted. When unit is closed, this will provide a theft resistant, non-control operation and reduce vandalism.
- Locks:** Pin tumbler, commercial quality locks keyed like all other AJW cabinets.
- Spindles:** (U005) Fabricated of one-piece molded high impact black ABS material.
- Overall Size:** 6"W x 12"H x 6 3/4"D
152mm x 305mm x 171mm
- Capacity:** Two standard rolls with a 5 1/4" (133mm) OD..

INSTALLATION

Provide an area on mounting surface at desired or specified location. Open cabinet, remove spindles and hold unit to wall at desired location. Transfer mounting points and drill pilot holes. Secure unit with proper fasteners per each application. Load toilet tissue on rollers, place in concealed track and close hood. Raise lower roll against upper and take hand away. Lower roll should fall into place with upper roll remaining up above the hood line. If loaded properly, top roll will not fall for use until bottom roll has been depleted. When servicing dispenser, full rolls must be used on both spindles to insure proper operation.

All toilet tissue dispensers that meet ADA code cannot have any type of control delivery. (4.16)

NOTES

Formerly Model #: U840A



UG2-A

Grab Bars

Revised 03/11

JOB #:

ITEM #:

QUANTITY:

MOUNTING	HANDING	TYPE	SIZE	OTHER

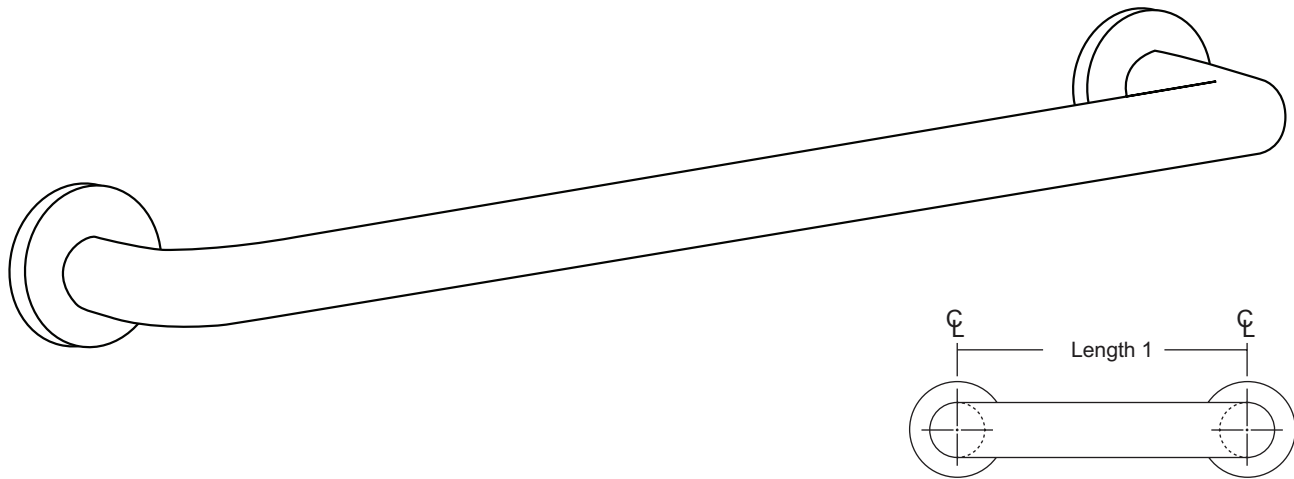

SPECIFICATIONS & INSTALLATION

Tubing: Fabricated of #18 ga stainless steel with a #4 satin finish. Available in 1 1/4" outside diameter. All bends are formed by an automatic mandrel bending process. All bars maintain a constant 1 1/2" offset.

Finish: Standard finish is a #4 satin finish. For a non-slip finish (peened) add suffix X to model number. (Ex. UG2X-A)

Flanges: Snap flanges are fabricated of 3" diameter, 3/8" deep drawn #22 ga stainless steel with #4 satin finish to match tubing. Flanges have dimples that secure over mounting plate.

Strength: Bars with a 1 1/2" offset clearance will support loads in excess of 900lbs when properly installed. Bars with greater offsets will support loads up to 250lbs when properly installed.

Installation: Before installing grab bars, verify with all state and local codes for requirements on bar diameter and type finish. Recommended mounting heights for grab bars are 33" - 36" centerline above finished floor. All mounting of grab bars when possible should have in wall mounting back plates. Find centerline mounting points and place bar on line making sure to be on center. Transfer mounting points (3 per flange) to wall. Drill pilot holes and secure bar with proper anchors per application. Snap cover over mounting plate.

Standard Lengths (Other sizes available upon request): 12", 16", 18", 24", 30", 32", 36", 42", 48", 50", 52", 54", 56"

FLANGE INFORMATION

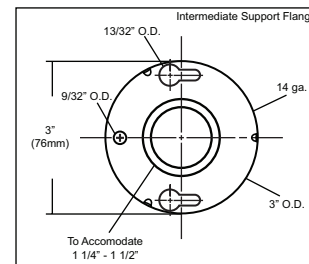
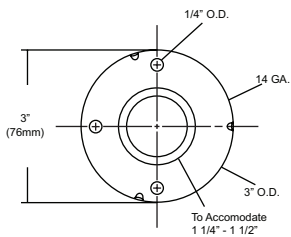
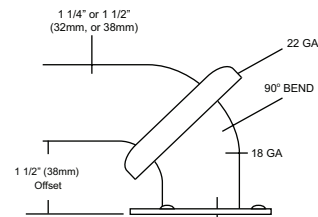

NOTES



UJ45 Series

Mop Holder & Hook Strip Combination Unit

Revision 03/11

JOB #:

ITEM #:

QUANTITY:

MOUNTING	HANDING	TYPE	SIZE	OTHER

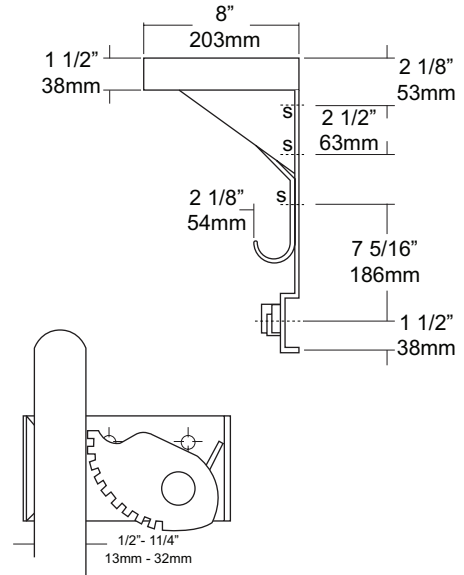
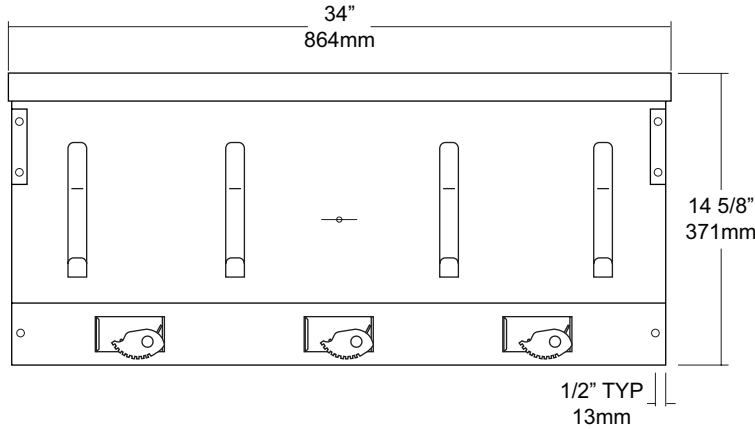

SPECIFICATIONS

- Shelf:** Fabricated of #18 ga stainless steel with a #4 satin finish, 8" deep (203mm) bent down 1 1/2" with 1/2" returns back for rigidity and safety.
- Back:** Fabricated of #18 ga stainless steel, #4 satin finish. Lower portion has a formed channel for added rigidity to support the mop holders.
- Mop Holders:** UJ19 plated reinforced steel with serrated cam type hard rubber mop or broom holder. Holds handles 1/2" to 1 1/4" diameter.
- Hooks:** #14 ga stainless steel with a #4 satin finish.
- Mounting Brackets:** #16 ga stainless steel with exposed mounting points.
- Verify Style:**
- UJ45A:** 34"L (864mm) with 3 holders, 4 hooks.
- UJ45B:** 44"L (1118mm) with 4 holders, 5 hooks.
- UJ45C:** 54"L (1372mm) with 5 holders, 6 hooks.

INSTALLATION

Place unit to wall surface making sure unit is level and transfer mounting points. Drill pilot holes and secure unit with proper fasteners per application.

NOTES



UX112-BF

Double Robe Hook

Revision 12/11

JOB #:

ITEM #:

QUANTITY:

MOUNTING	HANDING	TYPE	SIZE	OTHER

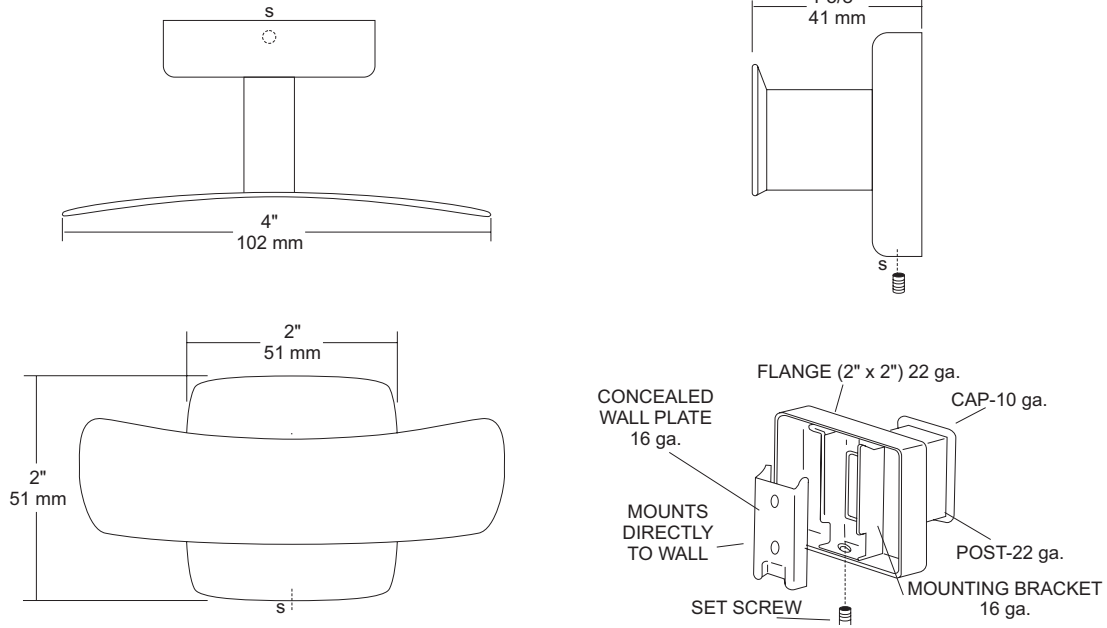

SPECIFICATIONS

UX Accessories: All UX bath accessories series are fabricated of stainless steel with a bright or satin finish. Mounting plates are concealed with a snap-on type plate secured by a set screw.

Hook: #10 ga stainless steel hook

Flange: 2" x 2" flange #22 ga stainless steel.

Post: #22 ga stainless steel.

Mounting Plate: #16 ga stainless steel concealed wall plate. Set screw secures mounting plate and flange.

Overall Size: 4"W x 2"H x 1 5/8"D

51mm x 51mm x 41mm

UX112-SF: Same as UX112-BF with satin finish.

INSTALLATION

Provide an area on wall surface at desired or specified location. Place concealed mounting plate on wall surface and transfer mounting points. Drill pilot holes and secure with proper fasteners. Place snap on flange over plate and secure with set screw.

NOTES