

date
projectname
attn
from
fax
email
phone

8-19-2016
Pioneer FCU
Bill Long
John Olszewski
724-693-8766
john@olszewskisales.com
724-6983-2666

JOB #:

ITEM #:

QUANTITY:

MOUNTING	HANDING	TYPE	SIZE	OTHER

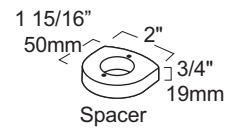
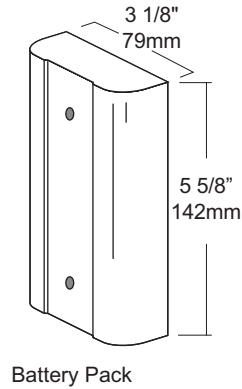
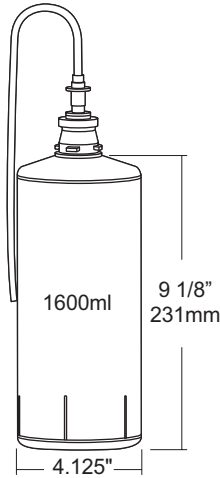
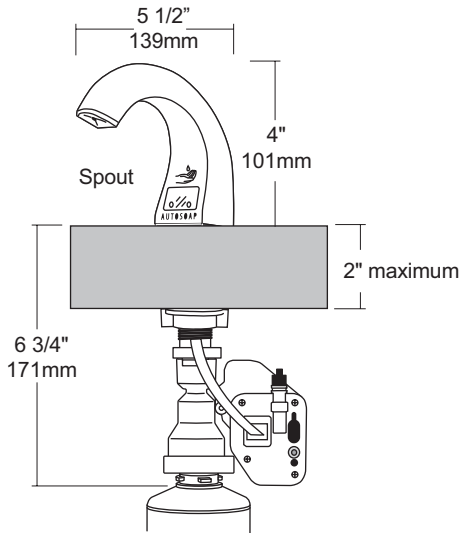

SPECIFICATIONS

Spout Assembly: Chrome and black plated ABS spout with automatic dispenser.

Shank Assembly: Black ABS high impact material. Requires a 1" diameter in counter top with a maximum thickness of 2". Optional spacer included if sink rim is 3/4" high or greater,

Electronics: Automatic sensor detects users hand to dispense a pre-determined amount LED light Indicator for low battery and low soap capacity. Four (4) D Alkaline batteries self contained motor assembly under counter. Average battery life 100 refills or 2 years.

Replaceable Containers: Self contained soap refills eliminate cross contamination, spills and lost service keys.

Capacity: Self contained non-refillable bottle with a capacity of aprx, 2000 hand washes per bottle, included with unit (lotion soap).

Overall Size: 5 1/2"D x 4 1/4"H (above vanity)

140mm x 108mm

INSTALLATION

If mounting on wall surface, transfer mounting hole dimensions from back of unit to wall surface. Drill pilot holes and secure unit to surface with proper fasteners. Sensor cannot be any higher than 40" above finished floor to comply with ADA code.

NOTES

Formerly Model #: U1800EA



U591
Surface Mounted Sanitary Napkin
Disposal
Revision 1/14

JOB #:
ITEM #:
QUANTITY:

MOUNTING	HANDING	TYPE	SIZE	OTHER

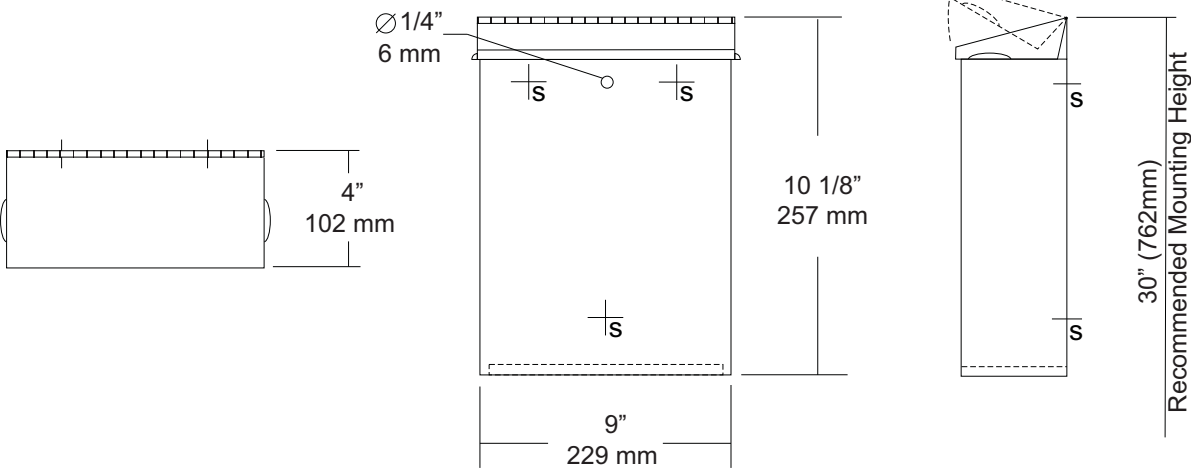

SPECIFICATIONS

Cabinet Body: Fabricated of #22 ga stainless steel with #4 satin finish. Seamless construction with radius and hemmed edges.

Cabinet Back: Stainless steel welded to cabinet body with key hole mounting points.

Cover: Fabricated of #22 ga stainless steel #4 satin finish with embossed handles on each side and sloped top.

Hinge: Heavy duty, full length, stainless steel piano type hinge.

Overall Size: 9"W x 10 1/8"H x 4"D

229mm x 257mm x 102mm

Capacity: 1.6 gallons (.2 cu ft)

NDL-13-50: Waxed disposable liners. (50 per Case)

INSTALLATION

Provide an area at desired or specified location. Place unit on surface and transfer mounting points. Drill pilot holes and secure with proper fasteners. Install waxed liner.

NOTES

JOB #:

ITEM #:

QUANTITY:

MOUNTING	HANDING	TYPE	SIZE	OTHER
----------	---------	------	------	-------

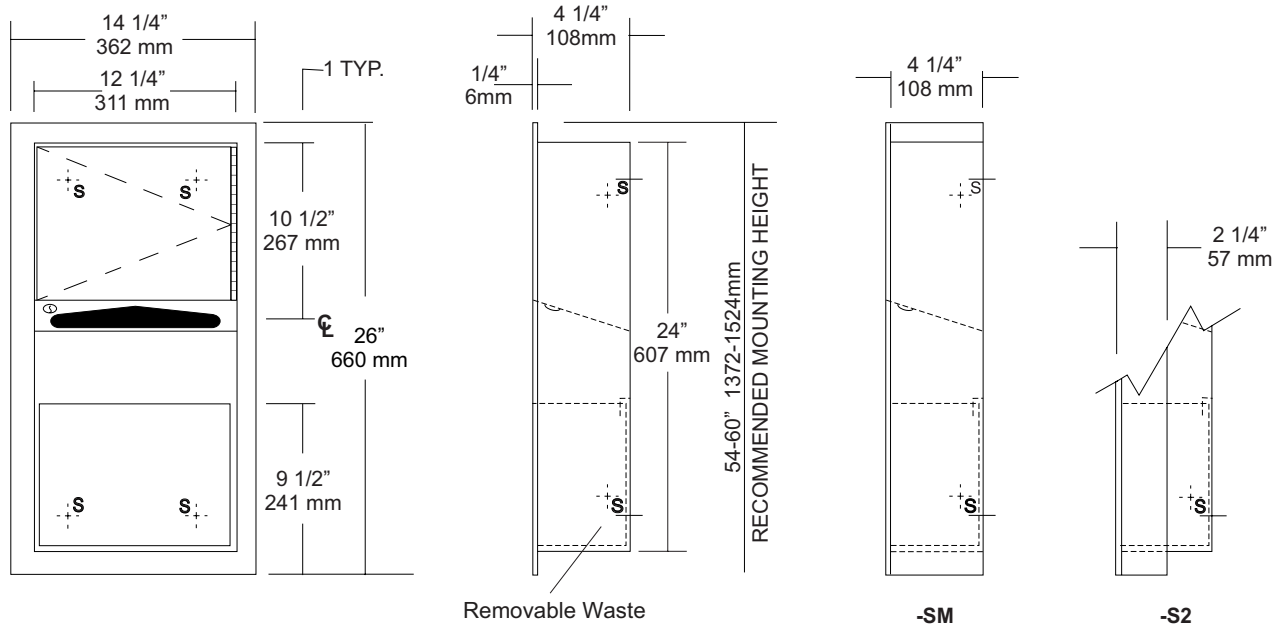

SPECIFICATIONS

Body: Fabricated of #22 ga stainless steel with a #4 satin finish.

Flange: Fabricated of #22 ga stainless steel with #4 satin finish and 1/4" returns to wall. (No miters or welds)

Cabinet Back: Fabricated of stainless steel formed for rigidity with multiple welds to cabinet body.

Cabinet Door: Fabricated of #22 ga stainless steel with #4 satin finish with full length door stop to prevent vandalism

Towel Dispenser: Dispensing area has hemmed edges to prevent injury and towel tearing.

Removable Waste: Stainless steel removable waste hemmed edges and embossed tabs for liners.

Hinges: Heavy duty, full length, stainless steel piano type hinge.

Lock: Pin tumbler commercial quality keyed like all other AJW cabinets.

Collars: Fabricated of #22 ga #4 satin finish stainless steel finished to match cabinet body.

Overall Size: 14 1/4"W x 26"H x 4 1/4"D
362mm x 660mm x 108mm

Wall Opening: 12 3/4"W x 24 1/2"H x 4"D
324mm x 622mm x 102mm

U626-S2: semi-recessed with 2" collar, 2" wall open. 51mm)

U626-SM: Surface mounted with full skirt.

Towel Capacity: 350 c-fold or 475 multifold

Waste Capacity: 2 gallons (.27 cu ft)

Options:

- VL3: Reusable vinyl liner.
- TK: Twist lock in lieu of keyed lock.

INSTALLATION

Coordinate installation with contractor and architect to avoid interference with pipes vents etc. Provide a rough wall opening 12 3/4"W x 24 1/2"H. Wall opening depth will depend on style mounting. Remove waste in install unit in opening. Make sure cabinet will sit flush in wall and secure with proper fasteners per application. Install waste back into cabinet and load paper towels.

When cleaning cabinet, use a soft cloth, a non-abrasive or chloric solutions.

NOTES

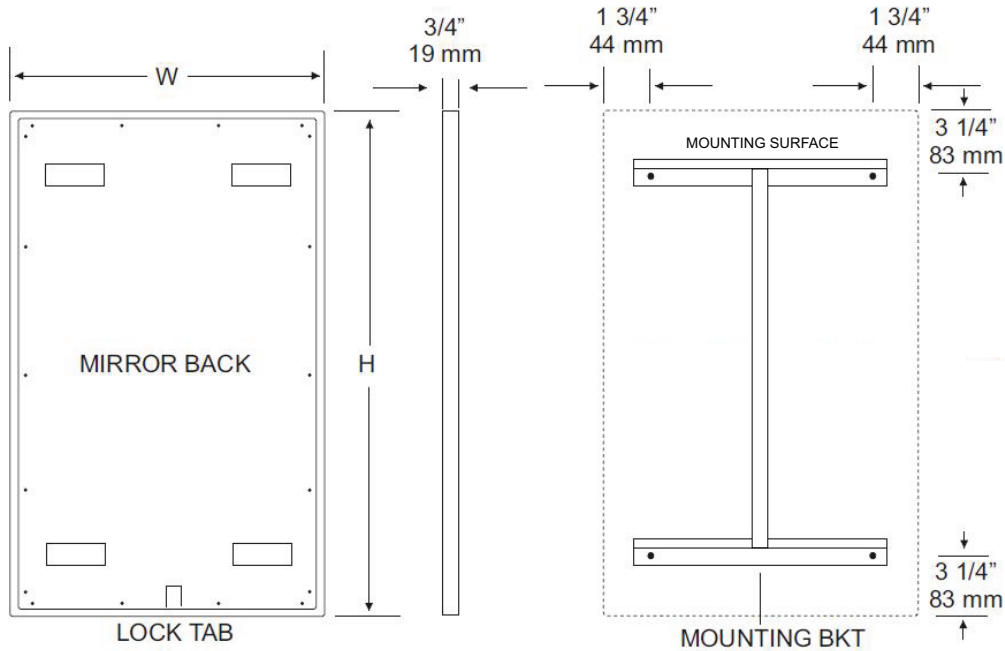

INSTALLATION

Coordinate installation with architect / contractor for specific mounting location and height for each mirror application. Making sure "I" bracket is level, transfer all mounting point locations to wall surface from drawing. Secure brackets with proper fasteners for each application. Slide mirror down over horizontal brackets until clip lock secures mirror in place. Mirror can only be removed by inserting tool through hole at bottom of frame depressing clip. This will allow mirror to slide up over brackets. Fillers are available if mirrors are mounted above and below tile line. (U004 Filler) Filler material will match mirror frame to form a one piece construction.

To meet ADA Code, bottom edge of reflective surface can be no higher than 40" above finished floor. (4.19.6) Full length mirrors may be used for universal application when installed in correct locations.

CARE & CLEANING

Wipe mirrors with a soft cloth, taking special care to rub stainless steel frames with the grain to avoid scratching. Do not use abrasive cleaners containing chloric solutions on stainless steel frames. Glass Plus or other window cleaning products are ideal.



U840 Toilet Tissue Dispenser

Revision 03/11

JOB #:

ITEM #:

QUANTITY:

MOUNTING	HANDING	TYPE	SIZE	OTHER

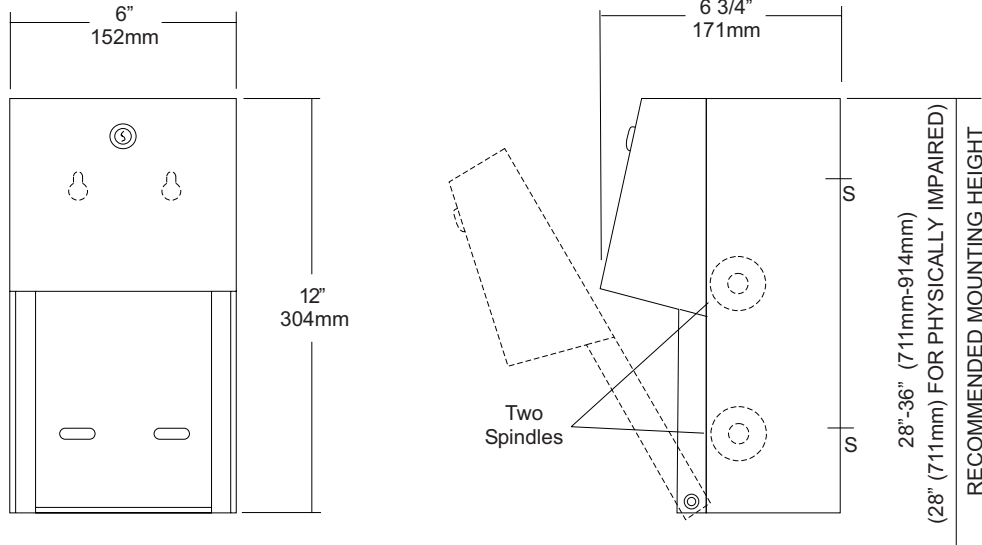

SPECIFICATIONS

- Body:** Fabricated of #22 ga stainless steel with #4 satin finish. Concealed inner dispensing mechanism is #18 ga stainless steel.
- Back:** Fabricated of #18 ga stainless steel with multiple welds to cabinet body forming a one piece construction.
- Hood:** Fabricated of #18 ga stainless steel finished to match cabinet body. Hood is secured with stainless steel hinge rivets to cabinet body. Top roll of tissue will not drop down unless the bottom roll has been depleted. When unit is closed, this will provide a theft resistant, non-control operation and reduce vandalism.
- Locks:** Pin tumbler, commercial quality locks keyed like all other AJW cabinets.
- Spindles:** (U005) Fabricated of one-piece molded high impact black ABS material.
- Overall Size:** 6"W x 12"H x 6 3/4"D
152mm x 305mm x 171mm
- Capacity:** Two standard rolls with a 5 1/4" (133mm) OD..

INSTALLATION

Provide an area on mounting surface at desired or specified location. Open cabinet, remove spindles and hold unit to wall at desired location. Transfer mounting points and drill pilot holes. Secure unit with proper fasteners per each application. Load toilet tissue on rollers, place in concealed track and close hood. Raise lower roll against upper and take hand away. Lower roll should fall into place with upper roll remaining up above the hood line. If loaded properly, top roll will not fall for use until bottom roll has been depleted. When servicing dispenser, full rolls must be used on both spindles to insure proper operation.

All toilet tissue dispensers that meet ADA code cannot have any type of control delivery. (4.16)

NOTES

Formerly Model #: U840A



UG3-A

Grab Bars

Revised 03/11

JOB #:

ITEM #:

QUANTITY:

MOUNTING	HANDING	TYPE	SIZE	OTHER



SPECIFICATIONS & INSTALLATION

Tubing: Fabricated of #18 ga stainless steel with a #4 satin finish. Available in 1 1/2" outside diameter. All bends are formed by an automatic mandrel bending process. All bars maintain a constant 1 1/2" offset.

Finish: Standard finish is a #4 satin finish. For a non-slip finish (peened) add suffix X to model number. (Ex. UG3X-A)

Flanges: Snap flanges are fabricated of 3" diameter, 3/8" deep drawn #22 ga stainless steel with #4 satin finish to match tubing. Flanges have dimples that secure over mounting plate.

Strength: Bars with a 1 1/2" offset clearance will support loads in excess of 900lbs when properly installed. Bars with greater offsets will support loads up to 250lbs when properly installed.

Installation: Before installing grab bars, verify with all state and local codes for requirements on bar diameter and type finish. Recommended mounting heights for grab bars are 33" - 36" centerline above finished floor. All mounting of grab bars when possible should have in wall mounting back plates. Find centerline mounting points and place bar on line making sure to be on center. Transfer mounting points (3 per flange) to wall. Drill pilot holes and secure bar with proper anchors per application. Snap cover over mounting plate.

Standard Lengths (Other sizes available upon request): 12", 16", 18", 24", 30", 32", 36", 42", 48", 50", 52", 54", 56"

FLANGE INFORMATION

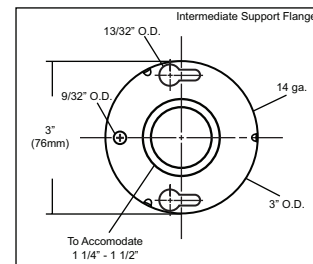
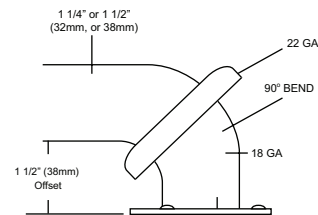

NOTES