

date
projectname
attn
from
fax
email
phone

2/8/21
Nashville MLS
Andrew Cassman



U126 Soap Dispenser

Revision 11/14

JOB #:

ITEM #:

QUANTITY:

MOUNTING	HANDING	TYPE	SIZE	OTHER



SPECIFICATIONS

Soap Tank: Fabricated of #20 ga stainless steel, #4 satin finish, fully welded one-piece construction.

Valve: All purpose antibacterial soap valve cylinder, black molded plastic push style valve that takes less than 5 lbs of force and one hand to operate complies with barrier free guidelines when mounted at proper height.

Viewer: Clear plastic window allows a constant fluid level check.

Concealed Mounting Plate: Fabricated of heavy gauge stainless steel.

Filler Cap: Fabricated of stainless steel, hinged to allow easy servicing, secured with special key that creates a vandal resistant dispenser.

Overall Size: 4 3/4"W x 8 1/4"H x 3 3/4"D (wall to valve)

121mm x 210mm x 95mm

Capacity: 40 oz.

Recommend type soaps without chloric solutions for proper operation.

INSTALLATION

Provide an area on mounting surface at desired or specified location. Secure concealed mounting plate to wall surface with proper fasteners. Slide dispenser down over mounting plate and secure by means of set screw located inside tank. Fill unit with proper soap. Close lid and secure with special key. Test valve for proper operation.

*It is not recommended to mount any soap dispenser on mirrors

**For best performance, use pre-mixed low concentrate solutions. Dispensers should have periodic maintenance performed to insure the life dispenser. Rinse out globe and valve with warm water to avoid sludge buildup.

Preventative Maintenance: Each dispenser should be flushed out aprx. Every 30 days with warm water to prevent valve from clogging with old soap. Do not use abrasive cleaners to clean dispenser.

NOTES

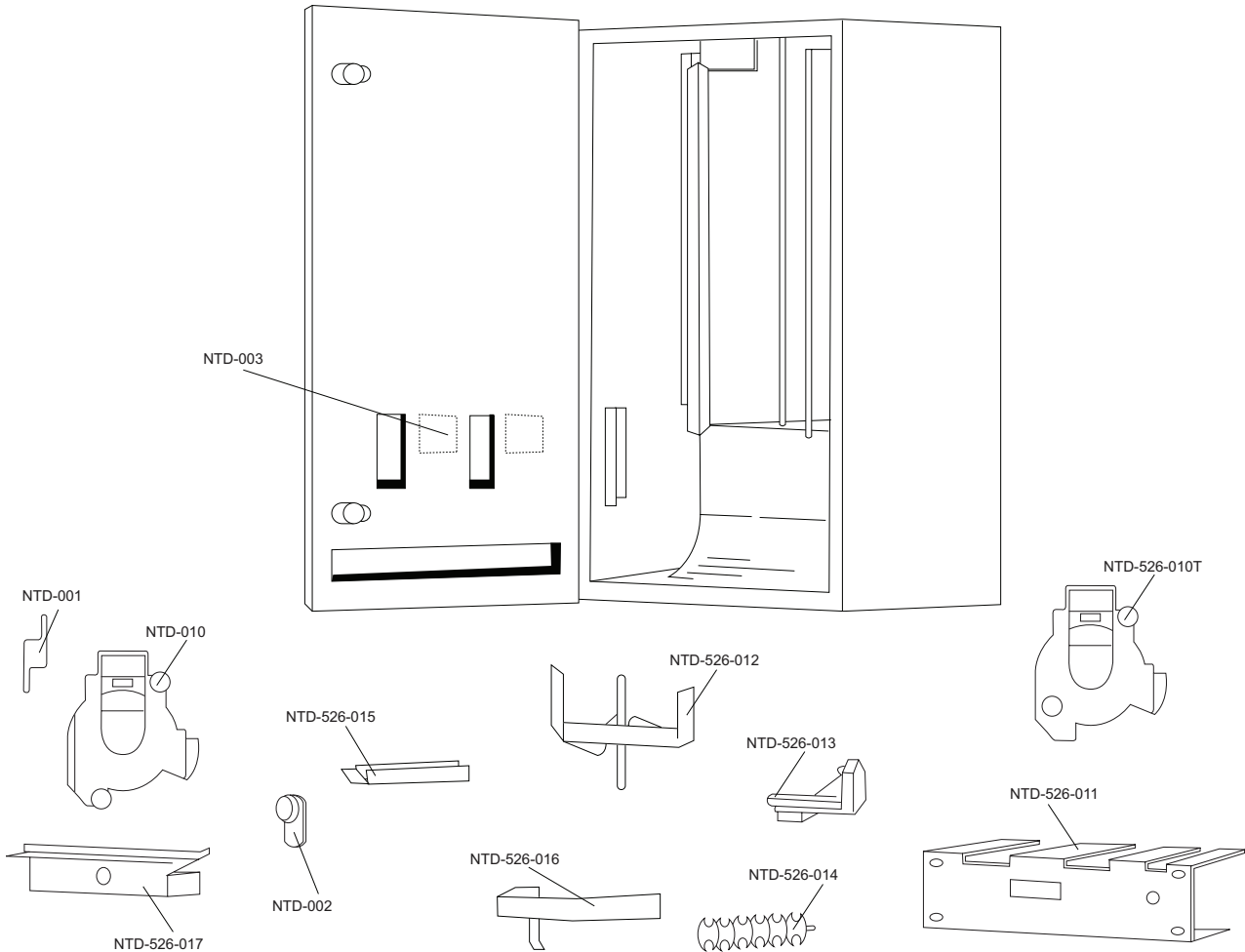

Part Number	Part Description
NTD-001	Turn knob with set screw
NTD-002	HL100 lock & key
NTD-003	Coin & denomination label
NTD-526-011	Mounting plate
NTD-526-012	Two stack finger plate
NTD-526-013	Flipper horn
NTD-526-014	Tampon rotor
NTD-526-015	Tampon weight
NTD-526-016	Napkin weight
NTD-526-10N	Coin mechanism for napkin dispenser only (.10, .25, .50 & Free)
NTD-010	Coin mechanism for tampon dispenser (.10, .25, .50 & Free)
NTD-526-017	Coin box



U526-SM

Surface Mounted Sanitary Napkin & Tampon Dispenser

Revision 03/11

JOB #:

ITEM #:

QUANTITY:

MOUNTING	HANDING	TYPE	SIZE	OTHER

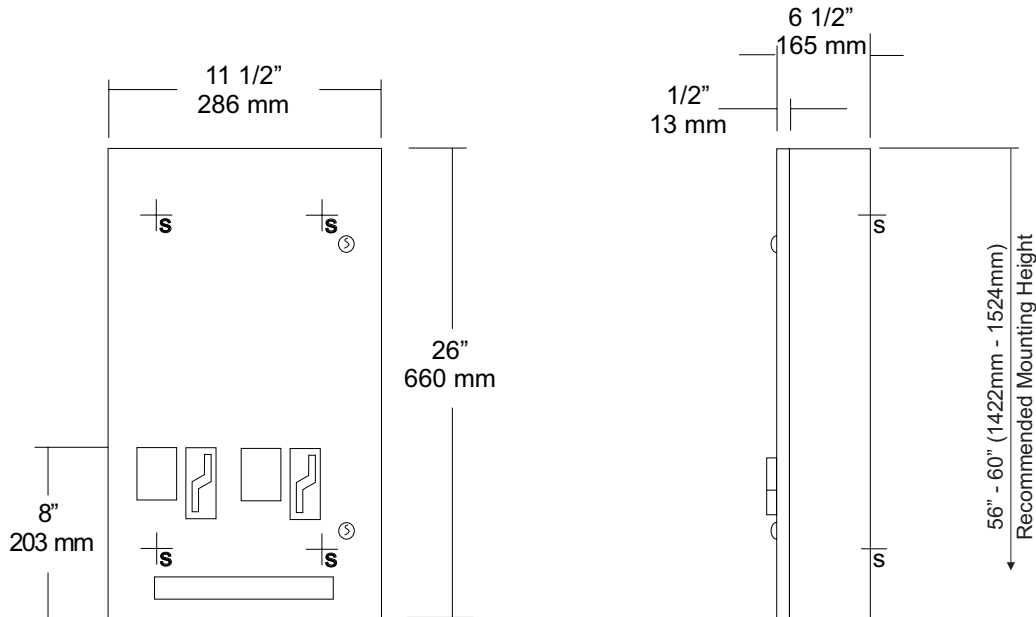

SPECIFICATIONS

Door: Fabricated of #18 ga stainless steel with #4 satin finish. Door has 1/2" returns for rigidity.

Body: Fabricated of #22 ga stainless steel with a #4 satin finish.

Coin Mechanisms: Two independent, trouble free turn knob mechanisms, with an "EMPTY" indicator that does not allow coins to be inserted into mechanism when product has been depleted. Operational with one hand with less than 5 lbs of force without tight grasping. Can be operated with palm, elbow or forearm if user has a physical impairment. (Free, .5, .10, .25, .50)

Hinges: Full length, heavy duty, stainless steel piano type hinge.

Locks: Pin tumbler, commercial quality, keyed like all other AJW cabinets. *(Coin box keyed differently then the door for security)

Overall Size: 11 1/2"W x 26"H x 6 1/2"D
292mm x 660mm x 165mm

Capacity: Napkins: 30, Tampons: 27

Verify Coinage: Napkin _____ Tampon _____

Recommended Package Sizes:

Napkins:

Min: 2 5/8"W x 4 1/8"L x 3/4"H

Max: 3 1/8"W x 4 1/2"L x 1 1/8"H

Tampons:

Min: 5/8" Dia. x 4 1/4"L

Max: 3/4" Dia. 5 1/8"L

INSTALLATION

Coordinate installation with architect or contractor to avoid interference with pipes, vents, etc. Open cabinet and transfer mounting points to wall surface after location is verified. Drill pilot holes and secure with proper fasteners per each application. Fill each chute with the proper products and make certain to place weights on the top product. Test operation of mechanism and dispensing of product before securing cabinet. Each cabinet comes with a parts list for ordering replacement parts if ever required.

*Note: Adjustable flange can be added to make unit Semi-Recessed. When mounted properly, unit will comply with ADA Code 4.27.4

NOTES

Formerly Model #: U527

U526-SM Installation Instruction Sheet

NTD-001	Turn knob with set screw
NTD-002	HL100 lock & key
NTD-003	Coin & denomination label
NTD-526-011	Mounting plate
NTD-526-012	Two stack finger plate
NTD-526-013	Flipper horn
NTD-526-014	Tampon rotor
NTD-526-015	Tampon weight
NTD-526-016	Napkin weight
NTD-526-10N	Coin mechanism for napkin dispenser only (.10, .25, .50 & Free)
NTD-010	Coin mechanism for tampon dispenser (.10, .25, .50 & Free)
NTD-526-017	Coin box

Overall Size: 11 1/2"W x 26"H x 6 1/2"D

Capacity: Napkins 30, Tampons 27

Package Sizes Dispensed:

Napkins:

Min: 2 5/8"W x 4 1/8"L x 3/4"H

Max: 3 1/8"W x 4 1/2"L x 1 1/8"H

Tampons:

Min: 5/8" Dia. x 4 1/4"L

Max: 3/4" Dia. 5 1/8"L

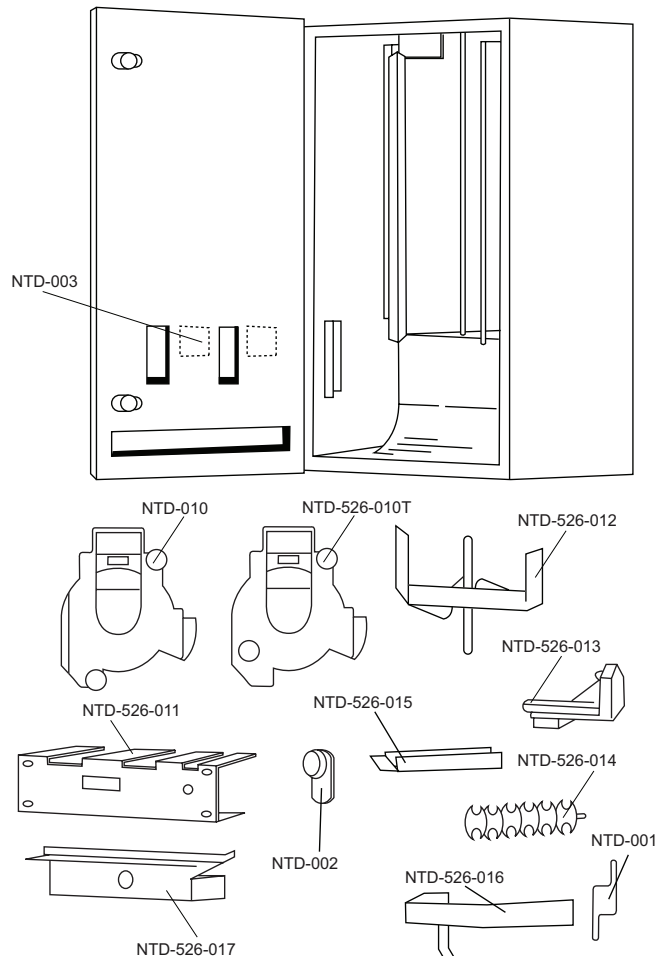

INSTALLATION & TROUBLESHOOTING

Surfaced Units: Secure surface mounted units to wall surface through back of unit with four (4) #10 screws provided

Recommended Mounting Height: Finished floor to turn knob mechanism 40" for ADA compliance.

Troubleshooting

My Unit Will Not Accept Coins: Check to see if chutes are empty. This unit has an automatic empty indicator which prevents coins from entering slot when chute is empty.

The Packages Get Hung Up In Chute: Check packages for size as recommended by manufacturer. Make sure packages have not been wet, bent, crushed or are out of shape in any other manner.

Check if weight is being used properly over packages to be dispensed in each chute. Check chutes and front door to see if it has been vandalized or tampered with. In many cases chutes are damaged when units are vandalized. If chutes cannot be straightened, they should be replaced.

FEATURES & INSTRUCTIONS

1. Peel off coinage labels
2. Separate coin box lock from door locks
3. Two separate mechanisms that can operate independently of one another and at different coinages. If one is damaged or breaks, it can be individually replaced.
4. Weights will indicate on turn knob mechanisms when chutes are empty and will not allow coins to be inserted.
5. High storage capacity

Refilling The Vendor

Napkins: Remove weight from napkin chute and fill with napkin packages. Replace weight on top of napkins and store reserve napkins in storage area.

Tampons: Remove weight from tampon chute and fill with tampons. Replace weight on top of tampons and store reserve tampons in storage area.

Ordering Labels: When ordering labels or mechanisms specify product and coinage for proper labels.



U775 Series
Surface Mounted Shelf

Revision 07/11

JOB #:

ITEM #:

QUANTITY:

MOUNTING	HANDING	TYPE	SIZE	OTHER

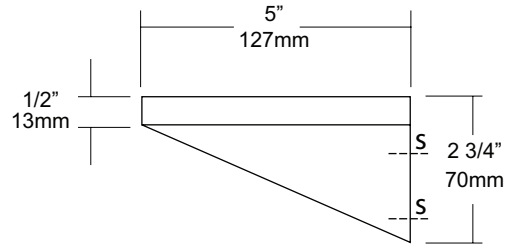
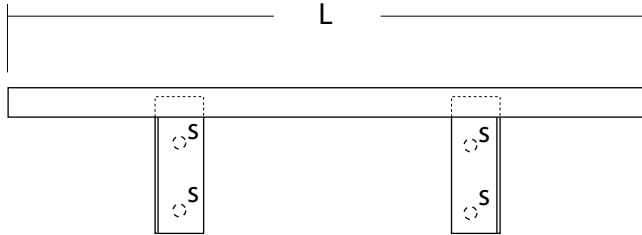

SPECIFICATIONS	INSTALLATION
-----------------------	---------------------

Shelves: Fabricated of #18 ga stainless steel. All edges are turned down 1/2" with front edges turned down & back 1/2" for maximum strength and rigidity. All corners are deburred and polished smooth for safety.

Brackets: Fabricated of #16 ga stainless steel permanently welded to shelf with exposed mounting points. Brackets are spaced maximum 30" centerline.

Surface mounted shelf 5"D (127mm)

Provide an area on wall surface at desired or specified location. Place unit up to wall making sure unit is level. Transfer mounting points to surface and drill pilot holes. Secure shelf to surface with proper fasteners per each application.

NOTES



U778 Series

Surface Mounted Shelf

Revision 07/11

JOB #:

ITEM #:

QUANTITY:

MOUNTING	HANDING	TYPE	SIZE	OTHER

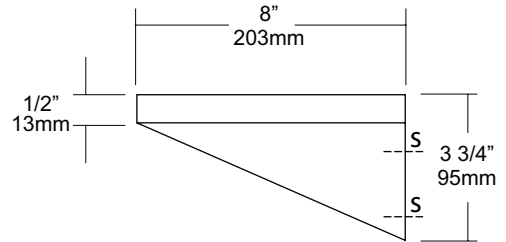
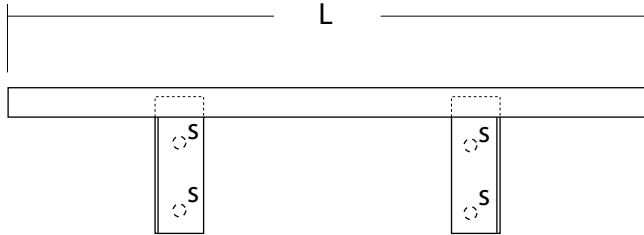

SPECIFICATIONS	INSTALLATION
----------------	--------------

Shelves: Fabricated of #18 ga stainless steel. All edges are turned down 1/2" with front edges turned down & back 1/2" for maximum strength and rigidity. All corners are deburred and polished smooth for safety.

Brackets: Fabricated of #16 ga stainless steel permanently welded to shelf with exposed mounting points. Brackets are spaced maximum 30" centerline.

Surface mounted shelf 8"D. (203mm)

Provide an area on wall surface at desired or specified location. Place unit up to wall making sure unit is level. Transfer mounting points to surface and drill pilot holes. Secure shelf to surface with proper fasteners per each application.

NOTES

JOB #:

ITEM #:

QUANTITY:

Mounting	Handing	Type	Size	Other

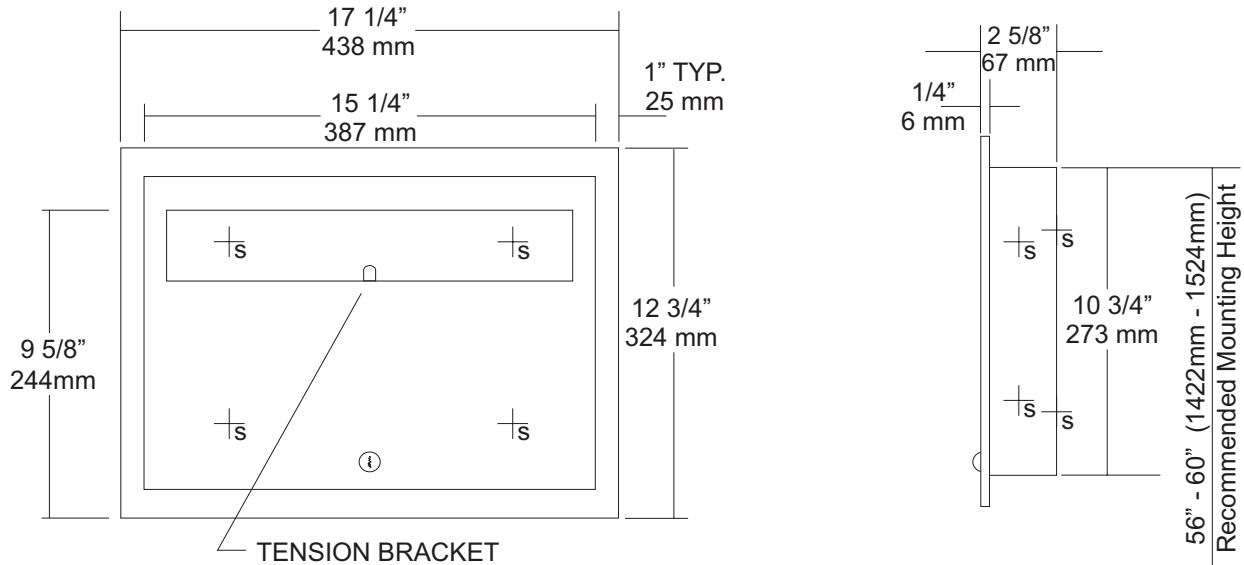

SPECIFICATIONS

Body: Fabricated of #22 gauge stainless steel with a #4 satin finish on all exposed surfaces.

Flange: #22 gauge stainless steel with 1/4" returns to wall without any miters.

Door: Fabricated of #22 gauge stainless steel with a #4 satin finish.

Locks: Pin tumbler, commercial quality locks keyed like all other AJW cabinets.

Overall Size: 17 1/4"W x 12 3/4"H x 2 5/8"D

438mm x 324mm x 68mm

Wall Opening: 15 3/4"W x 11 1/4"H x 2 3/8"D

400mm x 286mm x 60mm

U850-SM: Surface mounted unit

Capacity: 500 seat covers

INSTALLATION

Provide required wall opening at desired or specified location with coordination with architect or contractor to avoid interference with pipes, vents, etc. Unlock cabinet and place unit in opening. Secure to rough framing with proper fasteners per each application. Fill dispenser with product and secure cabinet door.

NOTES



U851
Seat Cover Dispenser

Revision 07/15

JOB #:

ITEM #:

QUANTITY:

MOUNTING	HANDING	TYPE	SIZE	OTHER

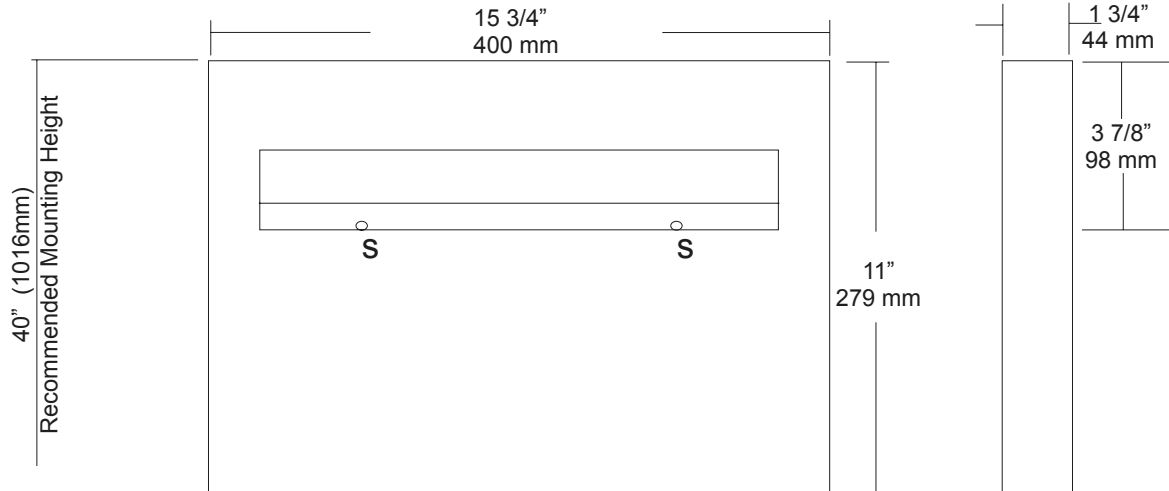

SPECIFICATIONS

Dispenser: Unit is fabricated of #22 gauge stainless steel with a #4 satin finish. Beveled edge around the dispensing areas ensures a clean dispensing area that prevents product from tearing and injury. Loading of product is accomplished from below without having to open any locking mechanism or access panel. Hat style mounting bracket provides added rigidity for body and acts as a support for the packaging.

Overall Size: 15 3/4"W x 11"H x 1 3/4"D

400mm x 279mm x 44mm

Capacity: 500 seat covers

INSTALLATION

Place unit on wall surface at desired or specified location making sure unit is level. Transfer mounting point locations and drill pilot holes for mounting. Secure unit to surface with proper fasteners per application. Product loads from the bottom out of site from public view.

NOTES



U933

Retractable Shower Seat

Revision 1/14

JOB #:

ITEM #:

QUANTITY:

MOUNTING	HANDING	TYPE	SIZE	OTHER

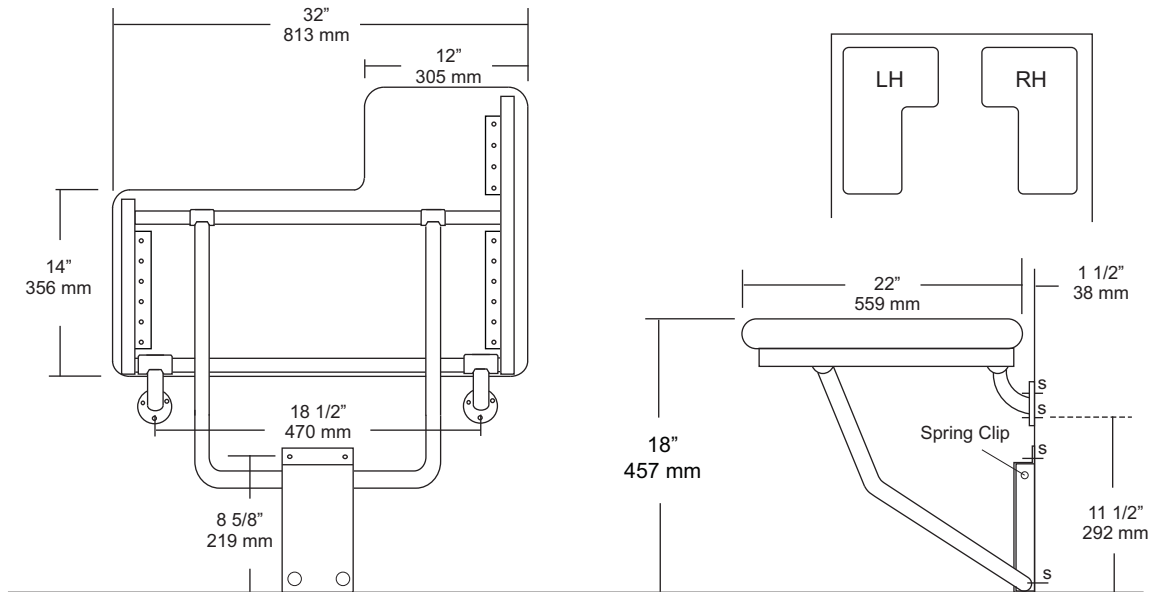

SPECIFICATIONS

- Seat:** Fabricated of 2 1/2" thick, water-resistant reinforced vinyl fabric cushion (white) seamless design with all leading edges having a radius. Seat is secured to a 1/2" thick marine plywood.
- Tubing:** Fabricated of #11 ga stainless steel with #4 satin finish.
- Main Frame:** #18 ga 1 1/4" with satin finish tubing. Underside has no exposed fasteners.
- Flanges:** #11 gauge stainless steel with four (4) exposed mounting points. Under slung supports have a 1 1/4" OD. (Satin finish)
- Mounting Bracket:** #16 ga stainless steel "hat" style bracket with 4 mounting support points. Bracket acts as a guide to raise and lower seat platform and is equipped with four (4) points to secure to wall surface. For maximum support, bracket is mounted so the bottom is set on the finished floor surface. Seat will remain in an upright position when not in use by means of a spring clip.
- Overall Size:** 32"W x 22"D (seating area)
813mm x 559mm
- U933L:** Left Handed
- U933R:** Right Handed

INSTALLATION

To comply with ADA Code, seat should be mounted at a height 17" - 19" above finished floor. Check all state and local codes for proper mounting requirements. Recommend in wall mounting on all shower seats. (BP10) Place seat up against wall making sure the extended part of seat has an offset no more than 1 1/2" away from wall. (Same as grab bar) Transfer mounting points to wall surface and drill pilot holes. Secure seat to surface with proper fasteners per each application. Snugly secure seat to surface and check seat to be level. If seat is level raise and lower seat to check path of travel. Finish securing seat after checking seat for proper operation. When properly mounted seat will support up to 250 lbs and will conform with ADA Code 4.21.3 and 4.26.3

Note: This shower seat is not intended to be installed in applications that have shower bases with rounded corners. AJW recommends the U928 for such applications.

NOTES

Formerly Model #: U933-1A



U944

Baby Changing Station

Revision 11/14

JOB #:

ITEM #:

QUANTITY:

MOUNTING	HANDING	TYPE	SIZE	OTHER
----------	---------	------	------	-------

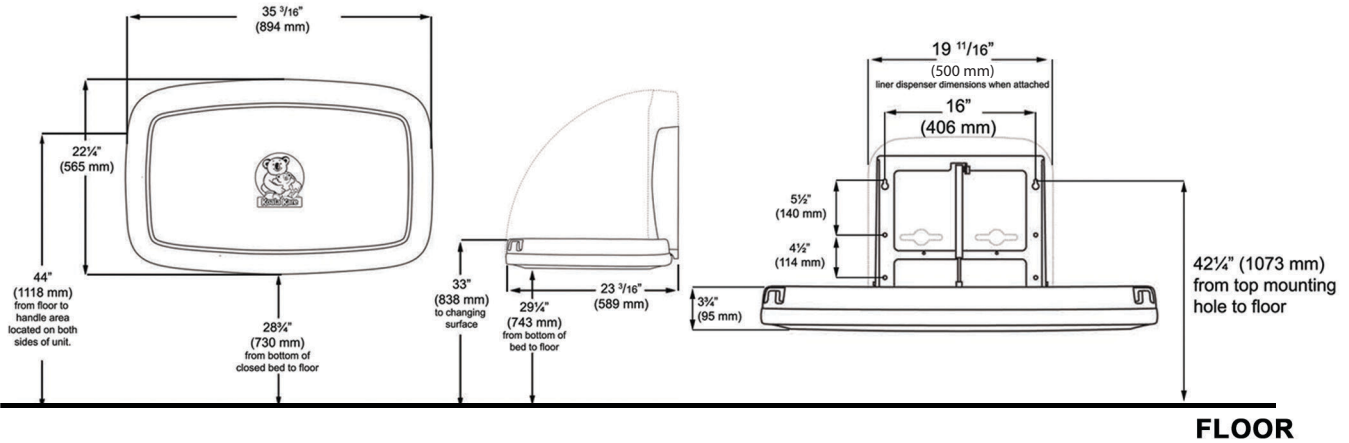

FLOOR

SPECIFICATIONS

Body: FDA approved injection molded polypropylene with Microban antimicrobial additive. Reinforced steel-on-steel hinge mechanism and metal mounting chassis. Labeled usage instructions and safety messages in four languages.

Liner Dispenser: An integral part of body that is standard with each unit. (Capacity: 50)

Pneumatic Cylinder: Concealed pneumatic cylinder & hinge structure provides controlled and smooth open and close motion.

Safety Straps: Nylon safety strap snap lock fastens to hold child securely in place.

Overall Size: 35 3/16"W x 22 1/4"H x 4"D (closed) 23 3/16"D (open)

894mm x 565mm x 102mm (closed), 589mm (open)

Available Colors: Cream & Grey

Optional Braille Label (Not included)

INSTALLATION

Coordinate installation with architect or contractor to avoid interference with surrounding objects. Hold unit up to wall and open to verify there are no obstructions to interfere with operation of station. From finished floor to the top of the unit closed should be at a height of 48". Transfer mounting point locations to wall surface and drill pilot holes. Secure unit with proper fasteners for each application. (Recommend a qualified carpenter to install unit) Unit can be lowered with one hand and into position with less than 5 lbs of force, wall opening turning or twisting of wrist. Verify with local codes and type approach (forward or side) for proper mounting height above finished floor. Unit can support up to 200lbs when properly installed.

Unit should be cleaned once or more daily with a clean nylon brush and spray disinfectant.

When properly installed, baby changing stations comply with ASTM static load performance requirements.

NOTES

Formerly Model #: U945H



U984 Baby Changing Station

Revision 07/15

JOB #:

ITEM #:

QUANTITY:

MOUNTING	HANDING	TYPE	SIZE	OTHER
----------	---------	------	------	-------

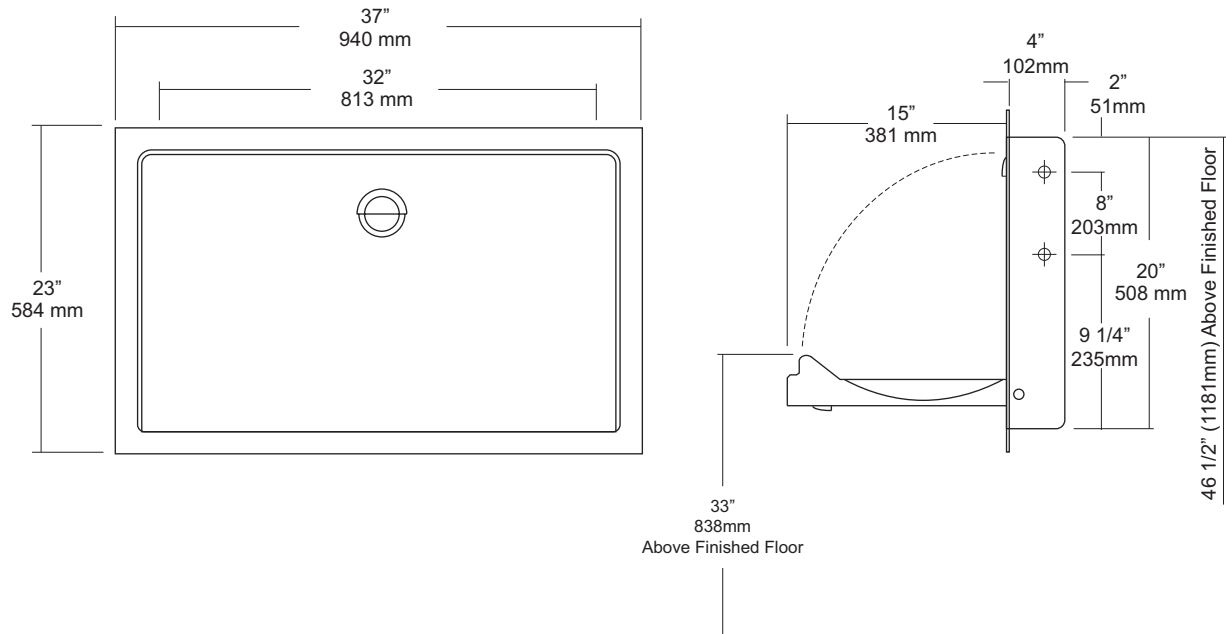

SPECIFICATIONS

Body: Fabricated of high impact ABS polyethylene with Microban Anti-Microbial additive, and radius leading edges that prevent injury. Material is odor resistant and easy to clean and available in grey. Base is concave formed to allow safe and easy changing. Molded graphics and brail comply with ADA code.

External Wrap: Fabricated of #18 ga stainless steel with a #4 satin finish. Wrap is reinforced with a full length steel on steel mechanism with #11 ga mounting plate.

Liner Dispenser: An integral part of body that is standard with each unit.

Gas Shocks: Concealed gas spring actuators ensure a safe and smooth open and close motion.

Safety Straps: Snap lock fasteners to hold child securely in place.

Overall Size: 37"W x 23"H x 4 1/4"D (closed) 15"D (open)

940mm x 584mm x 108mm (closed) 381mm (open)

Wall Opening: 35 1/2"W x 20 1/2"H x 4 1/4"D

Colors Available: Grey

INSTALLATION

Coordinate installation with architect or contractor to avoid interference with surrounding objects in and out of wall. Provide a rough wall opening 35 1/2"W x 20 1/2"H x 4 1/4"D. Making sure unit is level, secure with proper fasteners for each application. (Recommend a qualified carpenter to install unit) Unit can be lowered with one hand and into position with less than 5 lbs of force, wall opening turning or twisting of wrist. Verify with local codes and type approach (forward or side) for proper mounting height above finished floor. Mounting points are located on side of unit.

Unit should be cleaned once or more daily with a clean nylon brush and spray disinfectant.

When properly installed, baby changing stations comply with ASTM static load performance requirements.

NOTES

Formerly Model #: U945H-RSS



UB17

Heavy Duty Chrome Coat Hook

Revision 03/11

JOB #:

ITEM #:

QUANTITY:

MOUNTING	HANDING	TYPE	SIZE	OTHER

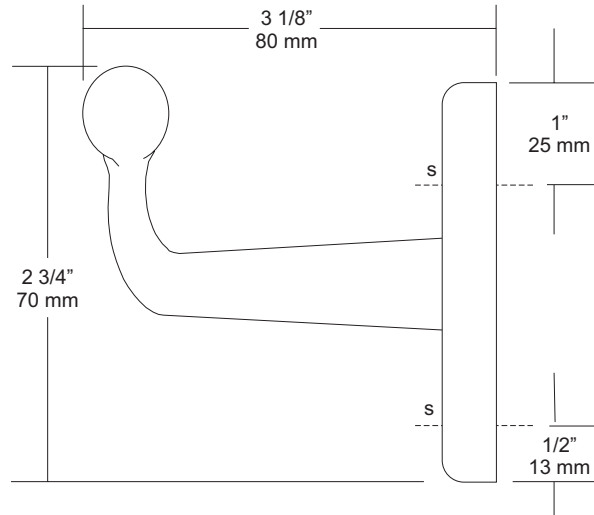
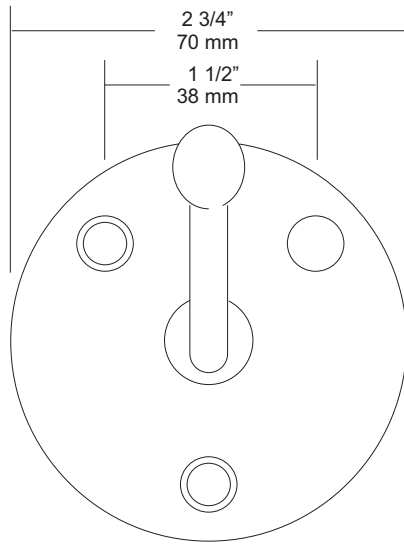

SPECIFICATIONS

UB Accessories: Fabricated of forged brass with a nickel and copper plating of chrome coating. In compliance with all standard commercial and government standards. Exposed mounting points (3) are countersunk to provide the fasteners a flush mount with flange.

Overall Size: 2 3/4" W x 2 7/8" H x 3 1/8" D

70mm x 73mm x 80mm

INSTALLATION

Place hook on mounting surface and transfer mounting points. Drill pilot holes and secure with proper fasteners per each application.

NOTES

Formerly Model #: UB15



UG3-A

Grab Bars

Revised 03/11

JOB #:

ITEM #:

QUANTITY:

MOUNTING	HANDING	TYPE	SIZE	OTHER



SPECIFICATIONS & INSTALLATION

Tubing: Fabricated of #18 ga stainless steel with a #4 satin finish. Available in 1 1/2" outside diameter. All bends are formed by an automatic mandrel bending process. All bars maintain a constant 1 1/2" offset.

Finish: Standard finish is a #4 satin finish. For a non-slip finish (peened) add suffix X to model number. (Ex. UG3X-A)

Flanges: Snap flanges are fabricated of 3" diameter, 3/8" deep drawn #22 ga stainless steel with #4 satin finish to match tubing. Flanges have dimples that secure over mounting plate.

Strength: Bars with a 1 1/2" offset clearance will support loads in excess of 900lbs when properly installed. Bars with greater offsets will support loads up to 250lbs when properly installed.

Installation: Before installing grab bars, verify with all state and local codes for requirements on bar diameter and type finish. Recommended mounting heights for grab bars are 33" - 36" centerline above finished floor. All mounting of grab bars when possible should have in wall mounting back plates. Find centerline mounting points and place bar on line making sure to be on center. Transfer mounting points (3 per flange) to wall. Drill pilot holes and secure bar with proper anchors per application. Snap cover over mounting plate.

Standard Lengths (Other sizes available upon request): 12", 16", 18", 24", 30", 32", 36", 42", 48", 50", 52", 54", 56"

FLANGE INFORMATION

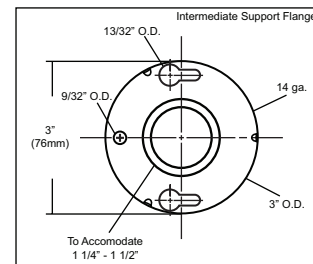
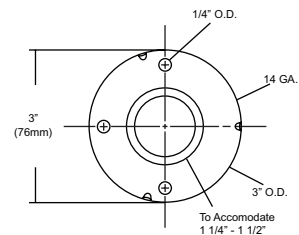
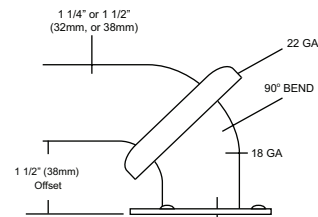

NOTES



UG3-G

Grab Bars

Revised 03/11

JOB #:

ITEM #:

QUANTITY:

MOUNTING	HANDING	TYPE	SIZE	OTHER

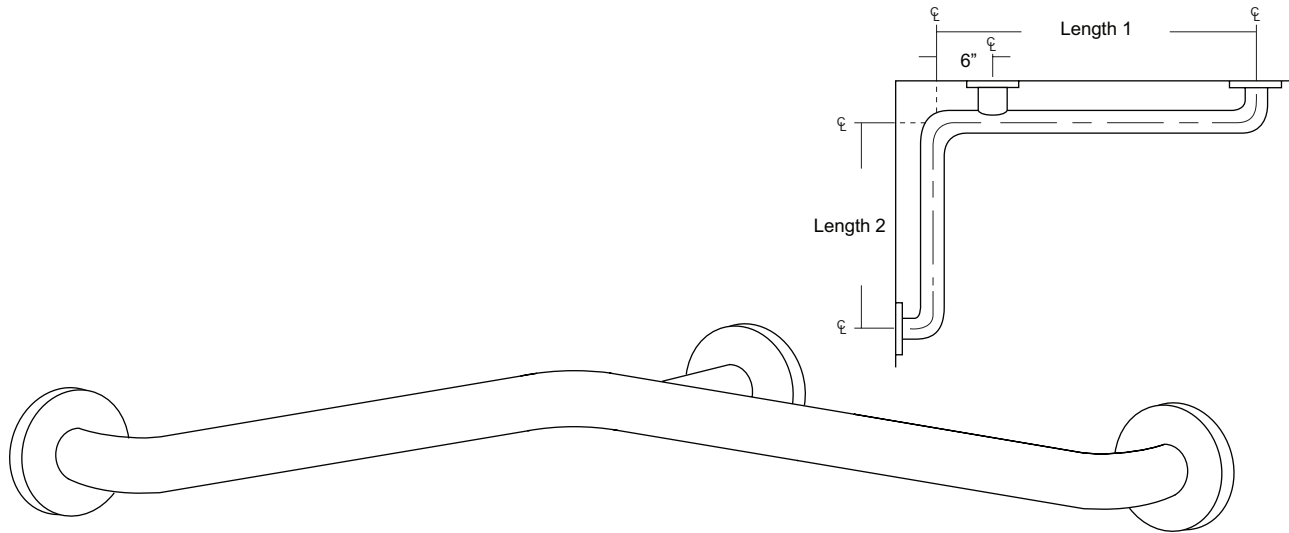

SPECIFICATIONS & INSTALLATION

Tubing: Fabricated of #18 ga stainless steel with a #4 satin finish. Available in 1 1/2" outside diameter. All bends are formed by an automatic mandrel bending process. All bars maintain a constant 1 1/2" offset.

Finish: Standard finish is a #4 satin finish. For a non-slip finish (peened) add suffix X to model number. (Ex. UG3X-G)

Flanges: Snap flanges are fabricated of 3" diameter, 3/8" deep drawn #22 ga stainless steel with #4 satin finish to match tubing. Flanges have dimples that secure over mounting plate.

Strength: Bars with a 1 1/2" offset clearance will support loads in excess of 900lbs when properly installed. Bars with greater offsets will support loads up to 250lbs when properly installed.

Installation: Before installing grab bars, verify with all state and local codes for requirements on bar diameter and type finish. Recommended mounting heights for grab bars are 33" - 36" centerline above finished floor. All mounting of grab bars when possible should have in wall mounting back plates. Find centerline mounting points and place bar on line making sure to be on center. Transfer mounting points (3 per flange) to wall. Drill pilot holes and secure bar with proper anchors per application. Snap cover over mounting plate.

Standard Lengths (Other sizes available upon request): 30" x 16", 30" x 18", 36" x 18", 36" x 24", 42" x 36", 54" x 36"

FLANGE INFORMATION

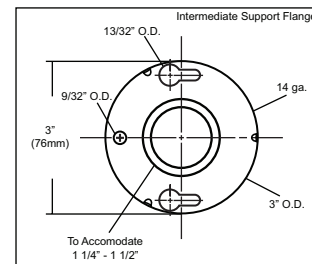
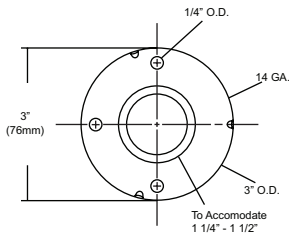

NOTES



UJ13 Series

Mop Holder Strip & Shelf Combination Unit

Revision 03/11

JOB #:

ITEM #:

QUANTITY:

MOUNTING	HANDING	TYPE	SIZE	OTHER

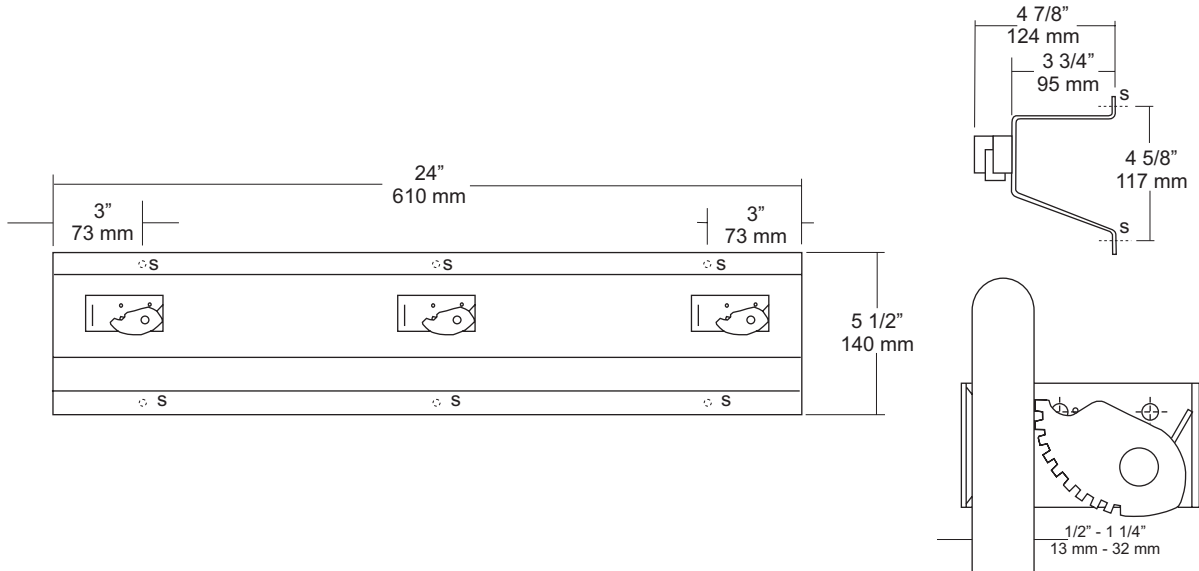

SPECIFICATIONS	INSTALLATION
----------------	--------------

Mop Strip & Shelf: Fabricated of #18 ga stainless steel with a #4 satin finish. Upper portion of strip is formed in the shape of a "hat" channel, that is utilized as a shelf, projects 3 3/4" from wall surface. Lower portion is angled to add rigidity and strength to strip.

Mop Holders: UJ19 plated reinforced steel with serrated cam type hard rubber mop or broom holder. Holds handles 1/2" to 1 1/4" diameter.

Verify Style:

UJ13A: 24"L (610mm) with 3 holders.

UJ13B: 36"L (914mm) with 4 holders.

UJ13C: 48"L (1219mm) with 5 holders.

UJ13D: 60"L (1524mm) with 6 holders.

Place unit to wall surface making sure unit is level and transfer mounting points. Drill pilot holes and secure unit with proper fasteners per application.

NOTES

JOB #:

ITEM #:

QUANTITY:

MOUNTING	HANDING	TYPE	SIZE	OTHER

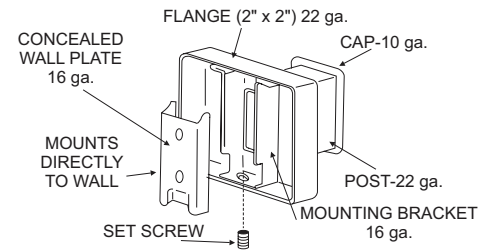
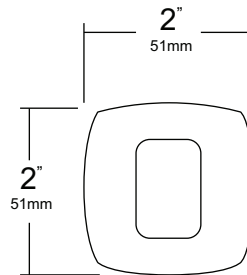
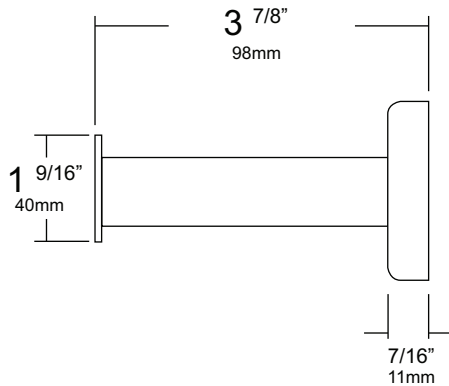

SPECIFICATIONS

UX Accessories: All UX bath accessories series are fabricated of stainless steel with a bright or satin finish. Mounting plates are concealed with a snap-on type plate secured by a set screw.

Hook: #10 ga stainless steel hook

Flange: 2" x 2" flange #22 ga stainless steel.

Post: #22 ga stainless steel.

Mounting Plate: #16 ga concealed wall plate. Set screw secures mounting plate and flange.

Overall Size: 2"W x 2"H x 3 7/8"

51mm x 51mm x 120mm

UX111-SF: Same as UX111-BF only satin finish in lieu of a bright finish stainless steel.

INSTALLATION

Provide an area on wall surface at desired or specified location. Place concealed mounting plate on wall surface and transfer mounting points. Drill pilot holes and secure with proper fasteners. Place snap on flange over plate and secure with set screw.

NOTES

UX250P Vinyl Shower Curtain

Installation & Cleaning Instructions

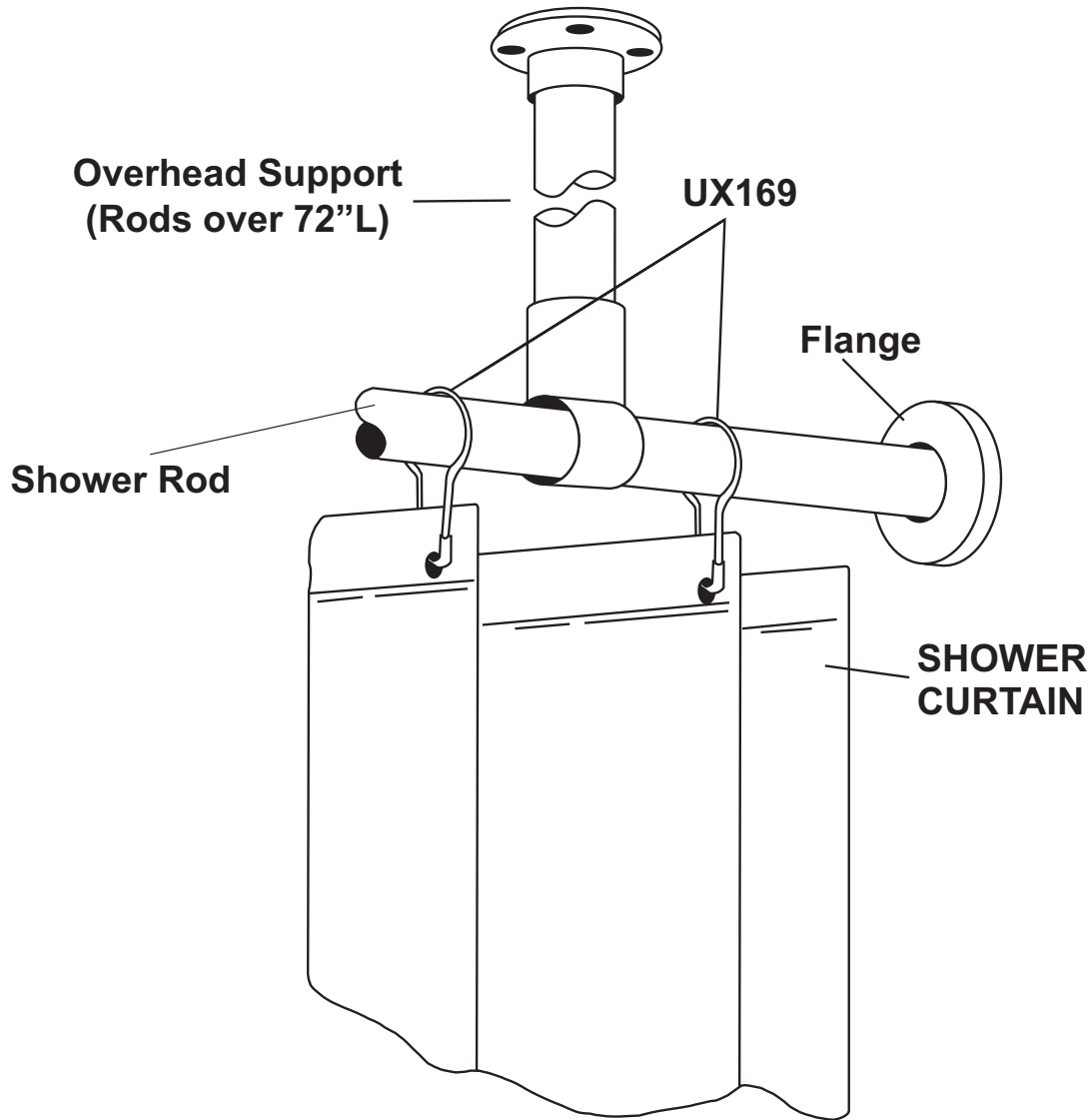

INSTALLATION

Recommended: UX169 stainless steel shower curtain hooks to connect to AJW shower curtain rods. Various types of flanges are available to secure rod and curtain to mounting surface (exposed and concealed).

Measuring Curtains: Curtains are measured W x H. The same curtain will fit a 1 or 1 1/4" diameter rod.

CARE & CLEANING

Machine wash cold water (not exceeding 41°C / 105°F). Do not bleach. Do not dry clean. Tumble dry low (not exceeding 140°F). Remove promptly.

JOB #:

ITEM #:

QUANTITY:

MOUNTING	HANDING	TYPE	SIZE	OTHER

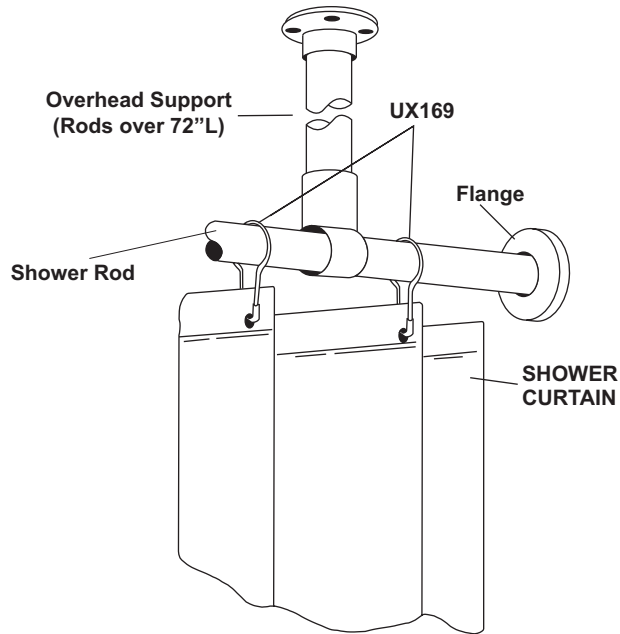

SPECIFICATIONS	INSTALLATION
----------------	--------------

Bacteria & Mildew Resistant: Heavy duty vinyl film (8 mil) that is flame retardant, durable and waterproof. Microbiotic KV-33 is an integral part added to the fabrication of this curtain that can be laundered repeatedly without losing this barrier against bacteria, fungus and mildew. KV-33 is a durable bacteriostat, mildewstat and fungistat that will provide protection for as long as you use this style curtain. It will retard the growth of organisms, thereby inhibiting odors caused by decaying bacteria.

Design: To insure the ultimate in bacteria free curtain, there are no side hems to hinder the flow-off of soap and water. This also makes cleaning easier. The heading is reinforced with a ten gauge vinyl film with rust proof anodized eyelets spaced 6" apart.

Cleaning: Sponge with warm mild soap and rinse with clear water.

Machine washing: Relatively cool water temp not to exceed 120 degrees F. DO NOT USE DETERGENTS. Air dry at low temp. Colors: Standard stock color is white. Special order for other colors are available on request.

***UX1-V/UX2-V:** Overhead s/s supports for oversized shower rods. (For shower rods over 72" in length an overhead support is recommended)

UX1-V: 1" OD shower rods.

UX2-V: 1 1/4" OD shower rods.

Recommended: UX169 stainless steel shower curtain hooks to connect to AJW shower curtain rods. Various types of flanges are available to secure rod and curtain to mounting surface (exposed and concealed).

Measuring Curtains: Curtains are measured W x H. The same curtain will fit a 1 or 1 1/4" diameter rod.

NOTES

Formerly Model #: 250P



UX2K

Flange & Shower Rod

Revision 03/11

JOB #:

ITEM #:

QUANTITY:

MOUNTING	HANDING	TYPE	SIZE	OTHER

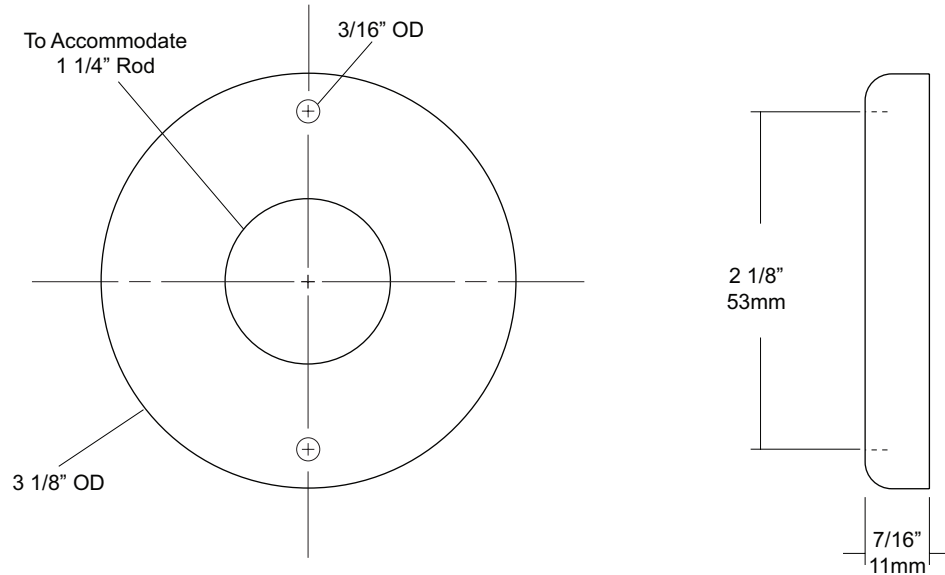

SPECIFICATIONS	INSTALLATION
----------------	--------------

Exposed Cover: Fabricated of #22 gauge stainless steel with a #4 satin finish. Cover has two (2) exposed mounting points.

Shower Rod: Fabricated of stainless steel with a #4 satin finish.

UX2: 1 1/4" outside diameter

Provide an area on wall surface at desired or specified location. Hold flange to wall surface and transfer mounting points. Drill pilot holes. Place flanges on the ends of the rods. Secure flanges to wall surface with proper fasteners per application.

NOTES