

date
projectname
attn
from
fax
email
phone

2/2/2017
q2w3h
q3we4rty
q3we4r
345678
2qwafr@egter
32456y7876



U450-12
Surface Mounted Waste Receptacle

Revision 10/14

JOB #:

ITEM #:

QUANTITY:

MOUNTING	HANDING	TYPE	SIZE	OTHER

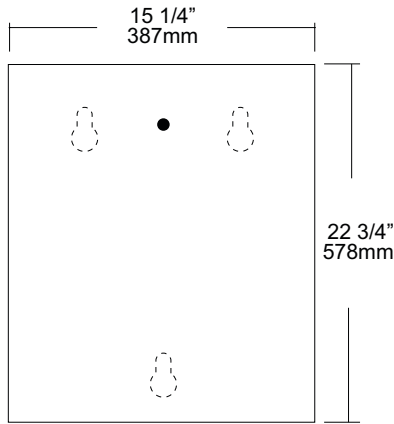
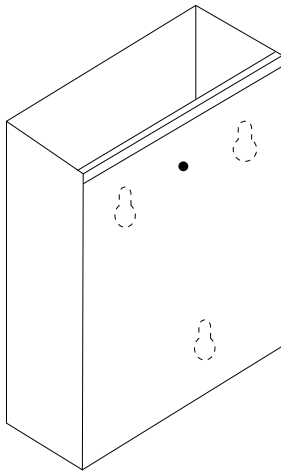

SPECIFICATIONS

Waste: Fabricated of #22 ga stainless steel with a #4 satin finish on all exposed surfaces. All leading edges are hemmed and have a radius to prevent injury.
Back: Fabricated of stainless steel formed for rigidity with multiple welds to cabinet body.
Overall Size: 15 1/4"W x 22 3/4"H x 8"D
387mm x 578mm x 203mm
Waste Capacity: 12 gallons (3.0 cu ft)
Options:
 -CV: Covered Waste
 -VL1 :13 gallon liner

INSTALLATION

Provide an area on wall surface at desired or specified location. Hold unit to wall surface, making sure unit is level and transfer mounting points. Drill pilot holes. Using proper fasteners per application, secure unit to wall surface.

NOTES

Formerly Model #: U460



U450-2
Surface Mounted Waste Receptacle

Revision 10/14

JOB #:

ITEM #:

QUANTITY:

MOUNTING	HANDING	TYPE	SIZE	OTHER

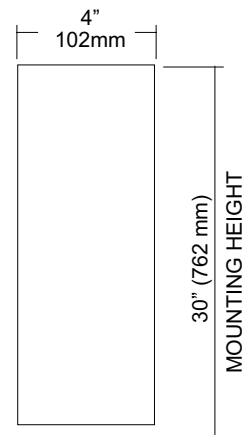
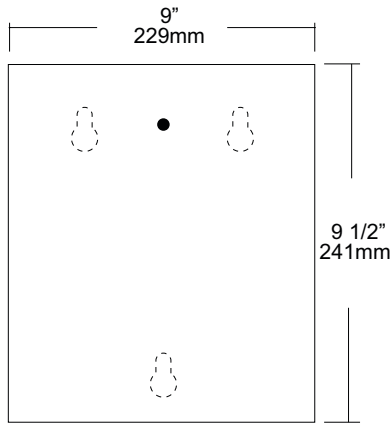
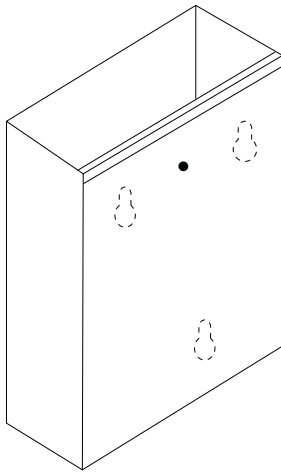

SPECIFICATIONS

Waste: Fabricated of #22 ga stainless steel with a #4 satin finish on all exposed surfaces. All leading edges are hemmed and have a radius to prevent injury.
Back: Fabricated of stainless steel formed for rigidity with multiple welds to cabinet body.
Overall Size: 9"W x 9 1/2"H x 4"D
229mm x 241mm x 102mm
Waste Capacity: 2 gallons (.26 cu ft)
Options:
 -CV: Covered Waste
 -VL3: 2.75 Gallon Liner

INSTALLATION

Provide an area on wall surface at desired or specified location. Hold unit to wall surface, making sure unit is level and transfer mounting points. Drill pilot holes. Using proper fasteners per application, secure unit to wall surface.

NOTES

Formerly Model #: U450



U450-21

Surface Mounted Waste Receptacle

Revision 03/11

JOB #:

ITEM #:

QUANTITY:

MOUNTING	HANDING	TYPE	SIZE	OTHER

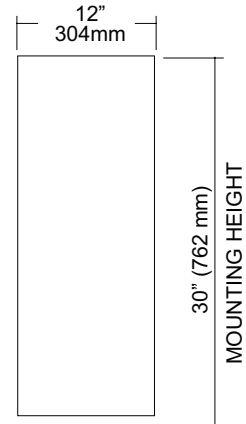
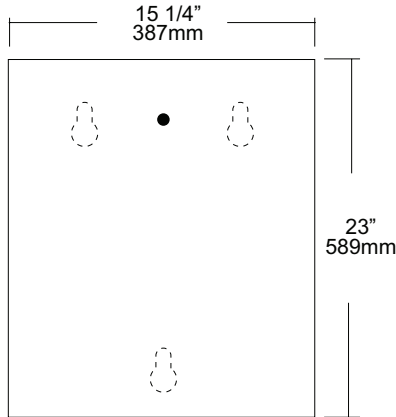
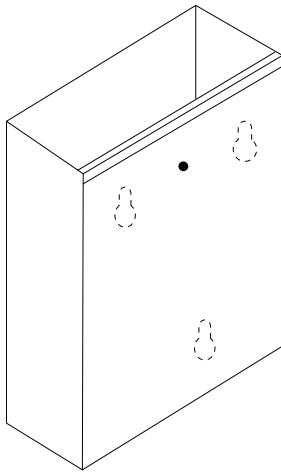

SPECIFICATIONS

Waste: Fabricated of #22 ga stainless steel with a #4 satin finish on all exposed surfaces. All leading edges are hemmed and have a radius to prevent injury.

Back: Fabricated of stainless steel formed for rigidity with multiple welds to cabinet body.

Overall Size: 15 1/4"W x 23"H x 12"D

387mm x 584mm x 305mm

Waste Capacity: 21 gallons (2.8 cu ft)

Options:

-CV: Covered Waste

-VL2: 25 gallon liner

INSTALLATION

Provide an area on wall surface at desired or specified location. Hold unit to wall surface, making sure unit is level and transfer mounting points. Drill pilot holes. Using proper fasteners per application, secure unit to wall surface.

NOTES

Formerly Model #: U465



U450-5
Surface Mounted Waste Receptacle

Revision 03/11

JOB #:

ITEM #:

QUANTITY:

MOUNTING	HANDING	TYPE	SIZE	OTHER

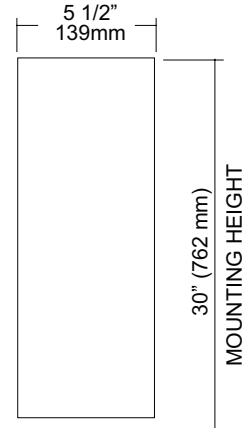
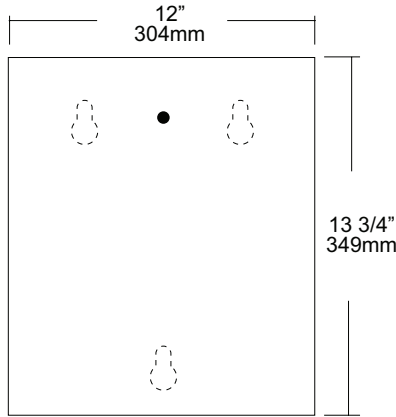
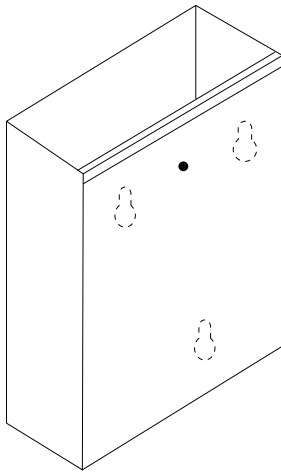

SPECIFICATIONS

Waste: Fabricated of #22 ga stainless steel with a #4 satin finish on all exposed surfaces. All leading edges are hemmed and have a radius to prevent injury.

Back: Fabricated of stainless steel formed for rigidity with multiple welds to cabinet body.

Overall Size: 12"W x 13 3/4"H x 5 1/2"D

305mm x 349mm x 140mm

Waste Capacity: 5 gallons (.66 cu ft)

Options:

-CV: Covered Waste

-VL7: 7 gallon liner

INSTALLATION

Provide an area on wall surface at desired or specified location. Hold unit to wall surface, making sure unit is level and transfer mounting points. Drill pilot holes. Using proper fasteners per application, secure unit to wall surface.

NOTES

Formerly Model #: U455



U450-7
Surface Mounted Waste Receptacle

Revision 03/11

JOB #:

ITEM #:

QUANTITY:

MOUNTING	HANDING	TYPE	SIZE	OTHER

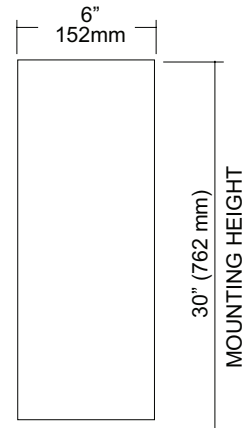
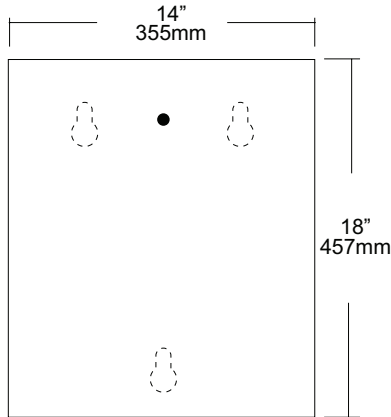
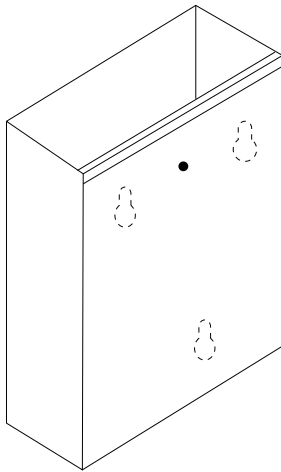

SPECIFICATIONS

Waste: Fabricated of #22 ga stainless steel with a #4 satin finish on all exposed surfaces. All leading edges are hemmed and have a radius to prevent injury.

Back: Fabricated of stainless steel formed for rigidity with multiple welds to cabinet body.

Overall Size: 14"W x 18"H x 6"D

356mm x 457mm x 153mm

Waste Capacity: 7 gallons (.93 cu ft)

Options:

-CV: Covered Waste

-VL7: 7 gallon liner

INSTALLATION

Provide an area on wall surface at desired or specified location. Hold unit to wall surface, making sure unit is level and transfer mounting points. Drill pilot holes. Using proper fasteners per application, secure unit to wall surface.

NOTES

Formerly Model #: U459