

date
projectname
attn
from
fax
email
phone

1-23-21
Snyder County Courthouse
D.H. Santiago
Schrader Architectural Products

santiago@schraderproducts.com
5703271492

JOB #:

ITEM #:

QUANTITY:

MOUNTING	HANDING	TYPE	SIZE	OTHER
----------	---------	------	------	-------

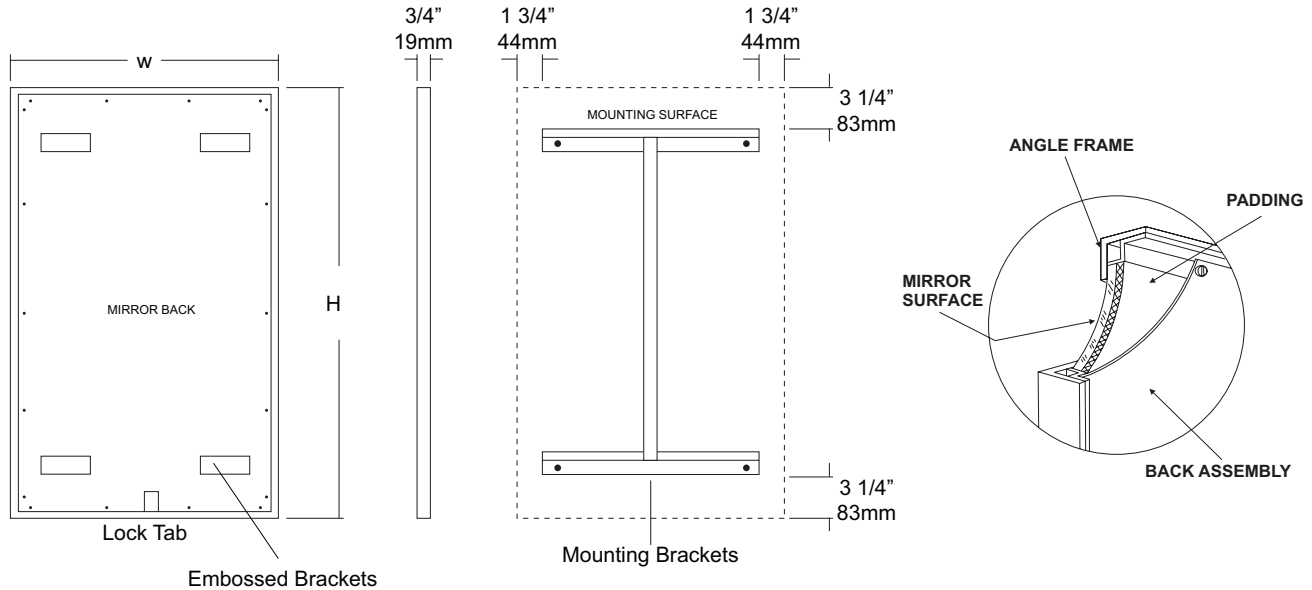

SPECIFICATIONS

Frame: Fabricated of #18 ga stainless steel, #4 satin finish. 3/4" x 3/4" frame with welded mitered corners are ground and polished smooth. #22 ga concealed "Z" channel is spot welded to inner perimeter of frame for reinforcement and greater rigidity.

Mirror: 1/4" thick type 1 transparent flat type, class 1 - clear glass mirrors. Mirror is coated with silver and sealed with a uniform electrolytic copper plating, along with two coats of paint for added protection. Mirrors are guaranteed against silver spoilage for a period of 15 years. Mirrors conform to ASTM C1036 and ASTM C1503-R8.

Filler: 3/16" thick full size, shock absorbing, water resistant, non-abrasive polyethylene padding protects all concealed mirror surfaces.

Back: #20 ga pre-plated galvanized steel, with embossed horizontal louver mounting brackets. Embossed theft resistant pressure activated clip lock device, locks mirror in place to wall hangers. Back is secured to frame with concealed Phillips head screws.

Hangers: Fabricated of #20 ga pre-plated steel galvanized steel with mounting points.

Standard Sizes Available (W x H): 16"x24", 16"x20", 16"x30", 18"x24", 18"x30", 18"x36", 20"x60", 24"x30", 24"x36", 24"x42", 24"x48", 18"x60", 24"x60", 24"x72", 18"x72"

Options:

- LG:** Laminated Glass
- LX:** Polycarbonate
- PM:** Plastic Acrylic
- T:** Tempered Glass
- VC:** Vinyl Clad (Safety Glass)
- 8B:** #8 Reflective Stainless Steel

* Stainless steel mirrors reflect images in different optic quality than plate glass. There will be a slight distortion which increases proportionately with the mirror size. Therefore, AJW Architectural Products™ cannot be held responsible for quality of image.

** Mirrors are always ordered Width x Height

*** Recommended max size for 8B mirrors: 72" x 47-1/2"

**** Framed mirrors are fabricated to a tolerance of (+/-) 1/8"

***** Mirrors conform to Federal Specifications DD-M-00411b & DDg-541D.

INSTALLATION

Coordinate installation with architect / contractor for specific mounting location and height for each mirror application. Making sure "I" bracket is level, transfer all mounting point locations to wall surface from drawing. Secure brackets with proper fasteners for each application. Slide mirror down over horizontal brackets until clip lock secures mirror in place. Mirror can only be removed by inserting tool through hole at bottom of frame depressing clip. This will allow mirror to slide up over brackets. Fillers are available if mirrors are mounted above and below tile line. (U004 Filler) filler material will match mirror frame to form a one piece construction.

To meet ADA Code, bottom edge of reflective surface can be no higher than 40" above finished floor. (4.19.6) Full length mirrors may be used for universal application when installed in correct locations.

Abrasive cleaners & chloric solutions should not be used on mirrors. Discoloring and /or scratching of frame and reflective surface may occur.

NOTES

JOB #:

ITEM #:

QUANTITY:

MOUNTING	HANDING	TYPE	SIZE	OTHER

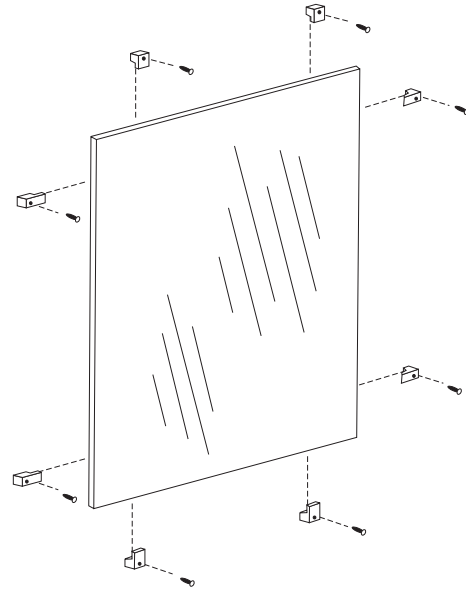
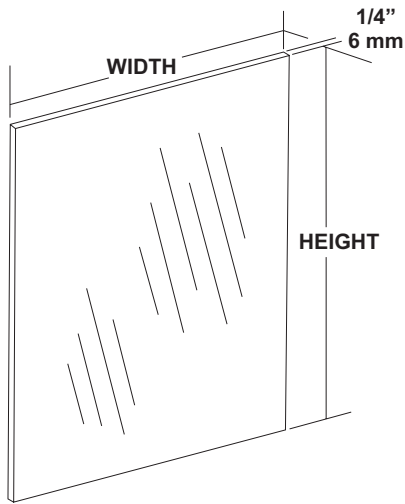

SPECIFICATIONS

Mirror: 1/4" thick type 1 transparent flat type, class 1 - clear glass mirrors. Mirror is coated with silver and sealed with a uniform electrolytic copper plating, along with two coats of paint for added protection. All frameless mirrors have polished edges. Mirrors are guaranteed against silver spoilage for a period of 15 years. Mirrors conform to ASTM C1036 and ASTM C1503-R8.

Recommended size one piece glass is 96" x 96"

Optional Surfaces and Sizes:

- PM: Plastic Mirrors (96" x 48" max size)
- LG: Laminated Glass (96" x 48" max size)
- BE: Beveled Edge Mirror: 1/4" plate glass with 1/2" Beveled Edge (72" x 60" max size)
- VC: Vinyl Clad (96" x 96")

***NOTE:** For oversized mirrors, recommend using U717 "J" mold style mirrors (Bottom, Top & Bottom or 4 sided) See U717 tech data sheet for more information.

Mounting Options:

- CL: Lucite Mirror Clips: (6 clips per pack)
- SCL: Stainless Steel Clips: (6 clips per pack)
- BCL: Lucite Mirror clips for beveled edge mirrors.

These Mirrors are always ordered Width x Height

Frameless mirrors are fabricated to a tolerance of ± 1/16"
Mirrors conform to Federal specification DD-M-00411b.

INSTALLATION

Provide an area on wall surface at desired or specified location. Select the proper clips for mounting. Mount the bottom clips approx. 1" in from each side of the overall width of the mirror. Place a level across the clips to make sure mirror will be level. Place glass on clips and check with level again. Follow same procedures for other clips. For oversized glass, it is recommended to have a minimum of a bottom "J" mold style mounting frame.

***Note:** Recommend 8 sq ft of glass per 1 pack of plastic clips. 8 sq ft of glass for stainless clips. The bottom reflective surface edge must be mounted 40" above finished floor to comply with ADA code, 4.19.6.

NOTES



U7018B Series

Stainless Steel Frameless Mirror

Revision 06/11

JOB #:

ITEM #:

QUANTITY:

MOUNTING	HANDING	TYPE	SIZE	OTHER

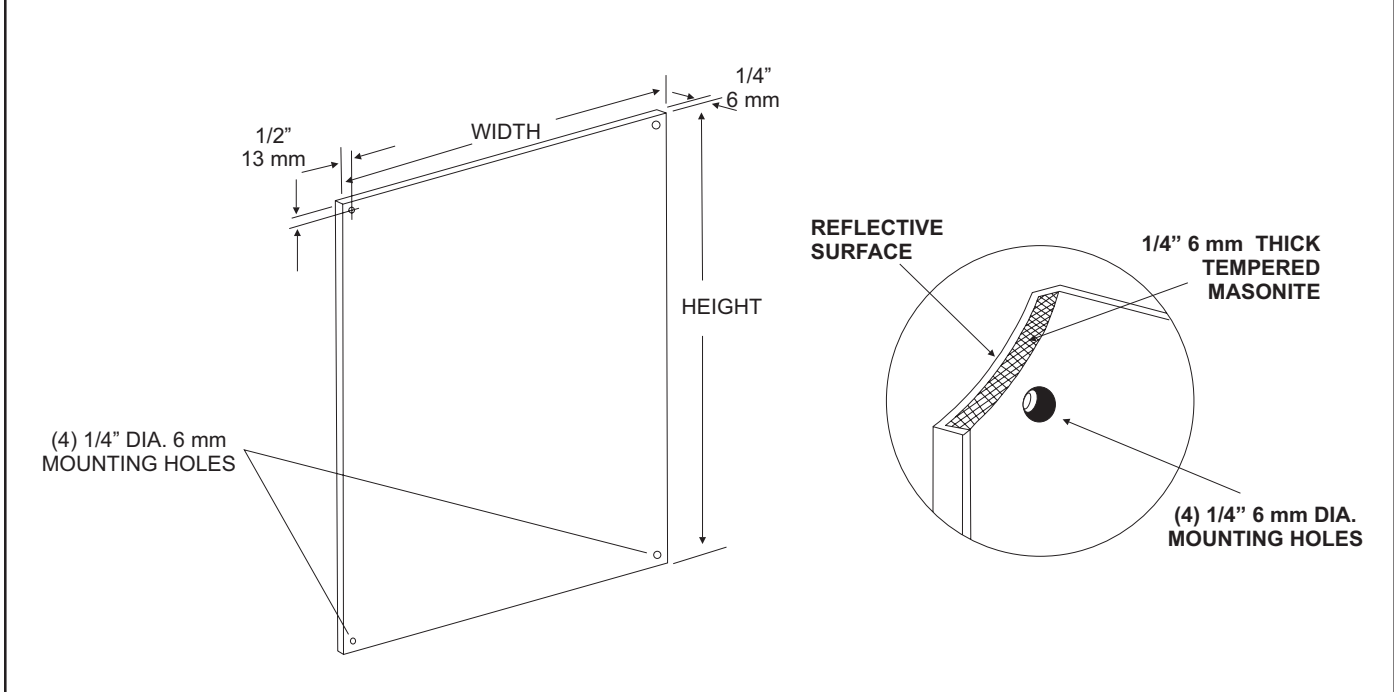

SPECIFICATIONS INSTALLATION

Mirror: Type 304 #20 ga stainless steel with #8B architectural finish. Both mirrors have 1/4" returns to wall surface for rigidity surrounding 1/4" thick tempered masonite backing. 1/4" diameter exposed mounting points are provided. Each mirror is shipped with a removable vinyl protective coating.

Note: Stainless steel mirrors reflect images in different optic quality than plate glass. There will be a slight distortion which increases proportionately with the mirror size. Therefore we cannot be held responsible for quality of image.

Cleaning: Non-abrasive and non-chloric solutions should be used to clean stainless steel mirrors.

These Mirrors are always ordered Width x Height

Provide an area at desired or specified location and strike a line that is level. Place mirror at this line and check again with level. Transfer mounting locations to wall surface and drill pilot holes. Peel off vinyl coating around corners only before securing to wall. Secure mirror with proper fasteners per each application. Do not over tighten fasteners. If a depression is formed by over-tightening the reflective quality may be affected. Remove remainder of vinyl coating after mirror checks with level and is properly secured. The bottom reflective surface edge must be mounted 40" above finished floor to comply with ADA code, 4.19.6.

NOTES

U7018B

Installation Instruction Sheet

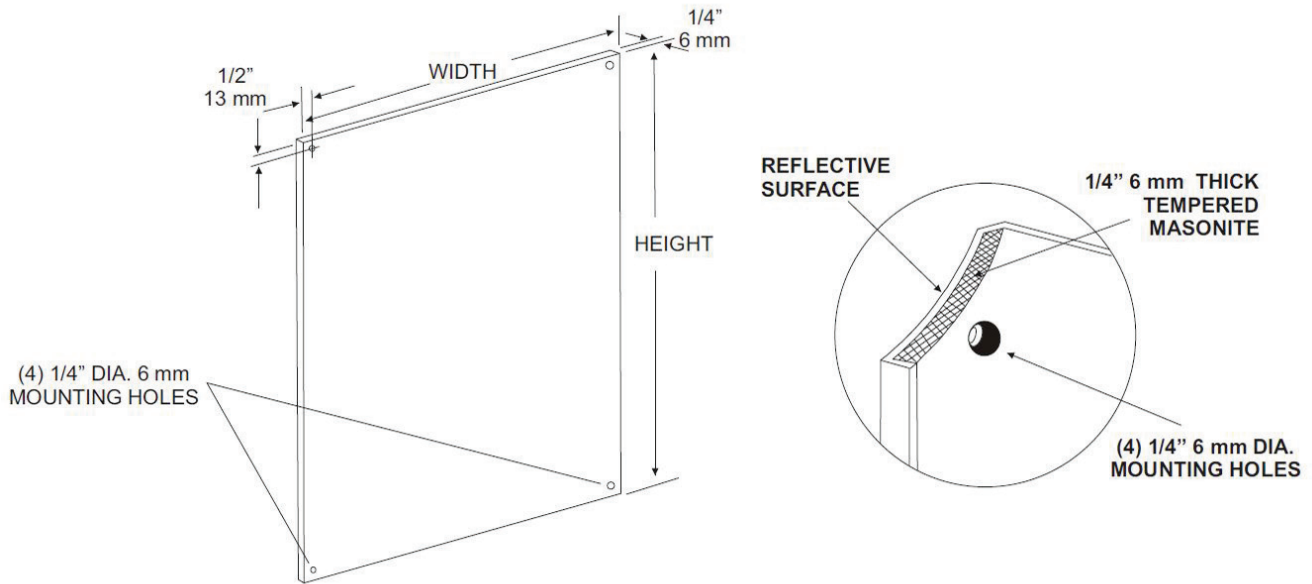

INSTALLATION

Provide an area at desired or specified location and strike a line that is level. Place mirror at this line and check again with level. Transfer mounting locations to wall surface and drill pilot holes. Peel off vinyl coating around corners only before securing to wall. Secure mirror with proper fasteners per each application. Remove remainder of vinyl coating after mirror checks with level and is properly secured. The bottom reflective surface edge must be mounted no higher than 40" above finished floor to comply with ADA code, 4.19.6.

CARE & CLEANING

Wipe mirrors with a soft cloth, taking special care not to rub stainless steel mirrors in a circular motions to avoid scratching. Do not use abrasive cleaners containing chloric solutions on stainless steel mirrors. Glass Plus or other window cleaning products are ideal.

U701 Installation Instruction Sheet

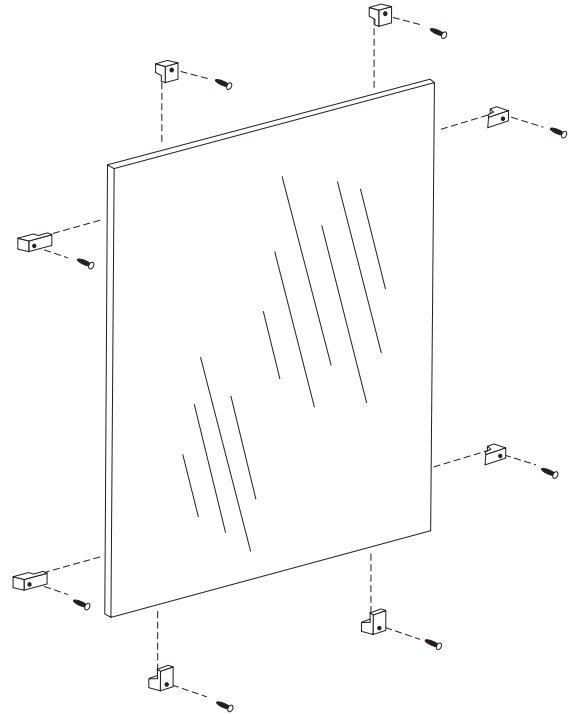
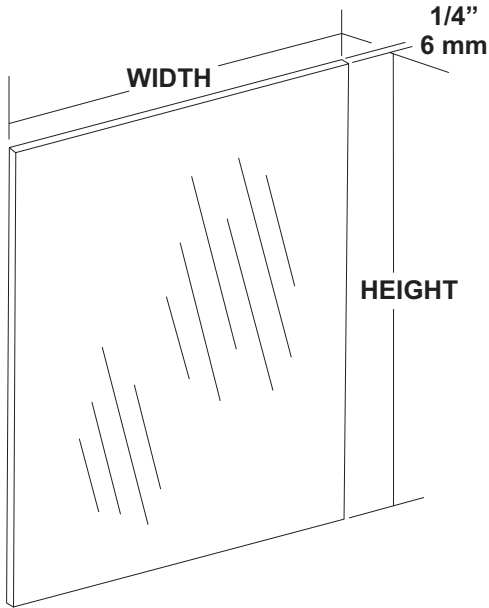

INSTALLATION

Provide an area on wall surface at desired or specified location. Select the proper clips for mounting. Mount the bottom clips aprx. 1" in from each side of the overall width of the mirror. Place a level across the clips to make sure mirror will be level. Place glass on clips and check with level again. Follow same procedures for other clips. For oversized glass, it is recommended to have a minimum of a bottom "J" mold style mounting frame.

*Note: Recommend 8 sq ft of glass per 1 pack of plastic clips. 8 sq ft of glass for stainless clips. The bottom reflective surface edge must be mounted 40" above finished floor to comply with ADA code, 4.19.6.

CARE & CLEANING

Wipe mirrors with a soft cloth, taking special care to rub stainless steel frames with the grain to avoid scratching. Do not use abrasive cleaners containing chloric solutions on stainless steel frames. Glass Plus or other window cleaning products are ideal.