

date
projectname
attn
from
fax
email
phone

2/24/21
Atrium MOB
James Allen

jallen@afvconstruction.com

MOUNTING	HANDING	TYPE	SIZE	OTHER
----------	---------	------	------	-------

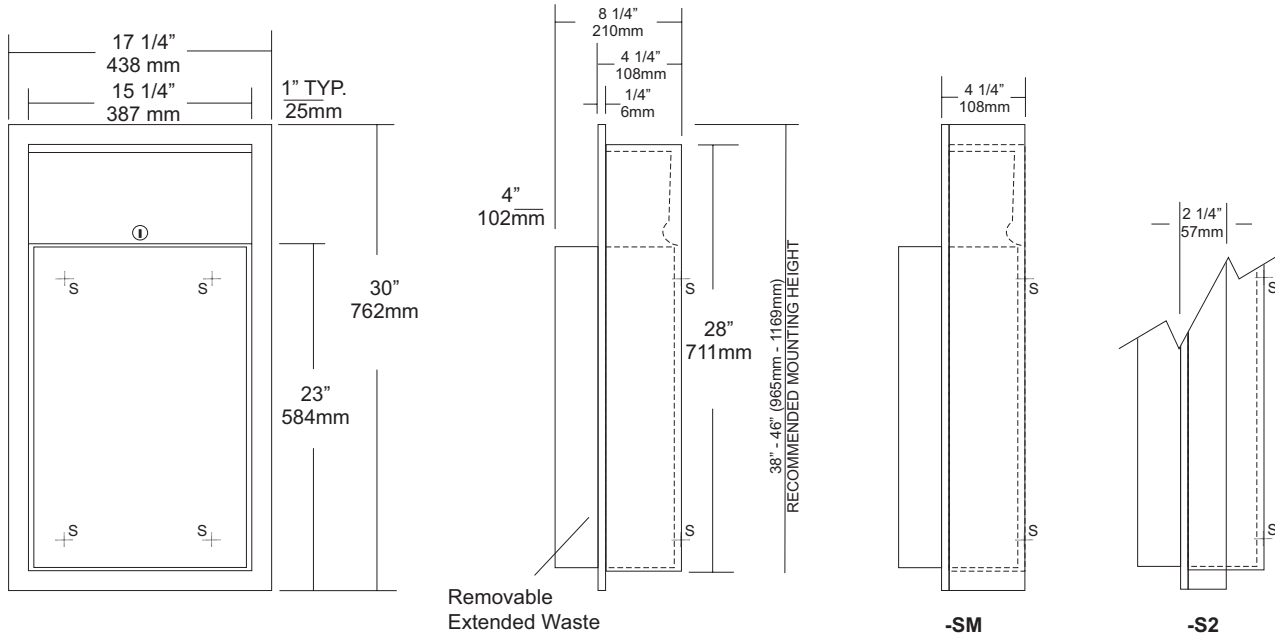

Removable
Extended Waste

-SM

-S2

SPECIFICATIONS

Body: Fabricated of #22 ga stainless steel with #4 satin finish on all exposed areas.

Flange: Fabricated of #22 ga stainless steel finished to match cabinet. One piece construction without miters or welds with 1/4" returns to wall surface for maximum strength.

Back: Fabricated of stainless steel formed for rigidity with multiple welds to cabinet body to form a one-piece construction.

Removable Waste: #22 ga stainless steel with #4 satin finish with hemmed edges and radius corners. Hook tabs allow liner to be installed are an integral part of waste can. Waste is secured in place by tumbler lock and bottom hanger. (12 gallon capacity)

Lock: Pin tumbler, commercial quality, keyed like all other AJW cabinets.

Collars: #22 ga stainless steel, sized & finished to match cabinet. (Used for surface mounting & semi-recessing)

Overall Size: 17 1/4"W x 30"H x 8 1/4"D (4" extended waste)
438mm x 762mm x 203mm

Wall Opening: 15 3/4"W x 28 1/2"H x 4"D
400mm x 724mm x 102mm

U410-S2: semi-recessed 2" collar(2" wall open.,51mm)

U410-SM: Surface mounting collar

Waste Capacity: 12 gallons (1.6 cu ft)

Options:

- VL1: Reusable vinyl liner
- CV: Covered Waste

INSTALLATION

Coordinate installation with architect and contractor. Provide a wall opening 15 3/4"W x 28 1/2"H . Wall depth will vary if collars are required. Remove waste from cabinet and insert into opening. Secure unit with proper fasteners for each application. Make sure each unit is plumb and true. Secure unit in cabinet by locking in place by tumbler lock. Liners may be installed. (VL1 Re-usable liner)

If semi-recessed cabinets are required see specification for wall depth's.

NOTES



U590
 Sanitary Napkin Disposal with Access
 Panel
 Revision 10/11

JOB #:
 ITEM #:
 QUANTITY:

MOUNTING	HANDING	TYPE	SIZE	OTHER

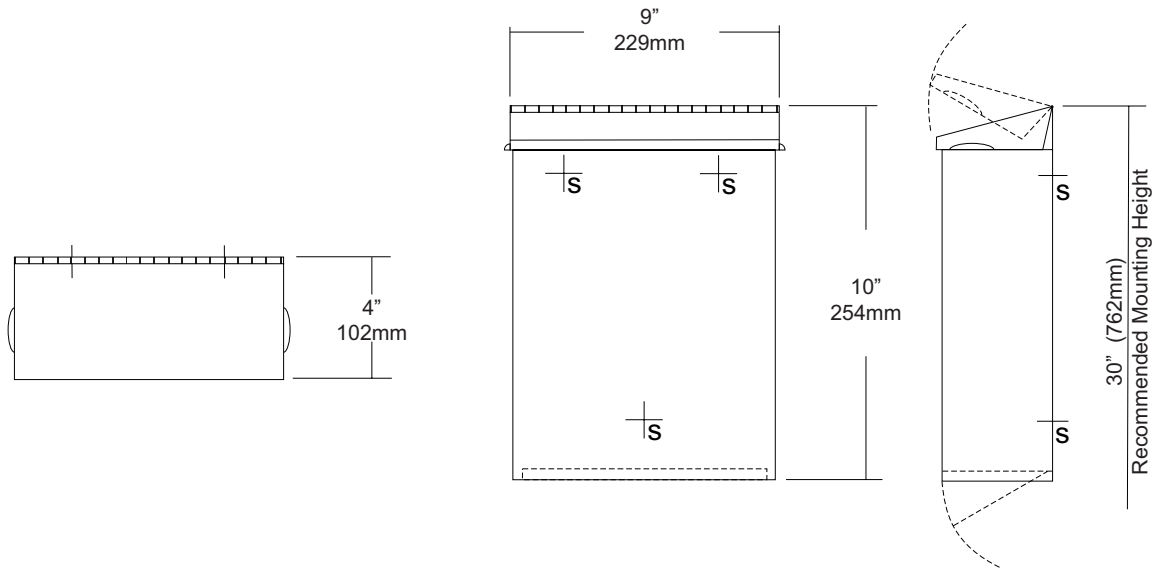

SPECIFICATIONS	INSTALLATION
----------------	--------------

Cabinet Body: Fabricated of #22 ga stainless steel with #4 satin finish. Seamless construction with radius and hemmed edges.

Cabinet Back: Fabricated of Stainless steel welded to cabinet body with key hole mounting points.

Cover: Fabricated of #22 ga stainless steel #4 satin finish with embossed handles on each side and sloped top.

Bottom Panel: #22 ga hinged and locked for removal of contents.

Hinges: Heavy duty, full length, stainless steel piano type hinges.

Lock: Commercial quality keyed like all other AJW cabinets.

Overall Size: 9"W x 10"H x 4"D
229mm x 254mm x 102mm

Capacity: 1.6 gallons (.2 cu ft)

NDL-13-50: Waxed disposable liners. (50 per Case)

Provide an area at desired or specified location. Place unit on surface and transfer mounting points. Drill pilot holes and secure with proper fasteners. Install waxed liner.

NOTES

JOB #:

ITEM #:

QUANTITY:

MOUNTING	HANDING	TYPE	SIZE	OTHER

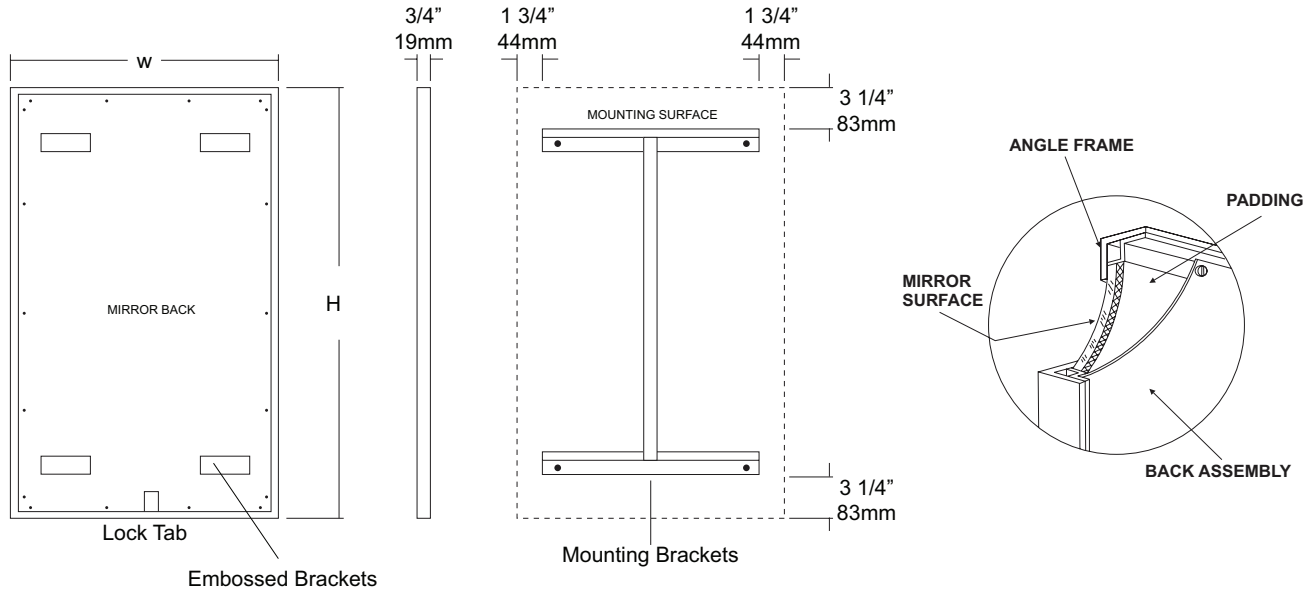

SPECIFICATIONS

Frame: Fabricated of #18 ga stainless steel, #4 satin finish. 3/4" x 3/4" frame with welded mitered corners are ground and polished smooth. #22 ga concealed "Z" channel is spot welded to inner perimeter of frame for reinforcement and greater rigidity.

Mirror: 1/4" thick type 1 transparent flat type, class 1 - clear glass mirrors. Mirror is coated with silver and sealed with a uniform electrolytic copper plating, along with two coats of paint for added protection. Mirrors are guaranteed against silver spoilage for a period of 15 years. Mirrors conform to ASTM C1036 and ASTM C1503-R8.

Filler: 3/16" thick full size, shock absorbing, water resistant, non-abrasive polyethylene padding protects all concealed mirror surfaces.

Back: #20 ga pre-plated galvanized steel, with embossed horizontal louver mounting brackets. Embossed theft resistant pressure activated clip lock device, locks mirror in place to wall hangers. Back is secured to frame with concealed Phillips head screws.

Hangers: Fabricated of #20 ga pre-plated steel galvanized steel with mounting points.

Standard Sizes Available (W x H): 16"x24", 16"x20", 16"x30", 18"x24", 18"x30", 18"x36", 20"x60", 24"x30", 24"x36", 24"x42", 24"x48", 18"x60", 24"x60", 24"x72", 18"x72"

Options:

- LG:** Laminated Glass
- LX:** Polycarbonate
- PM:** Plastic Acrylic
- T:** Tempered Glass
- VC:** Vinyl Clad (Safety Glass)
- 8B:** #8 Reflective Stainless Steel

* Stainless steel mirrors reflect images in different optic quality than plate glass. There will be a slight distortion which increases proportionately with the mirror size. Therefore, AJW Architectural Products™ cannot be held responsible for quality of image.

** Mirrors are always ordered Width x Height

*** Recommended max size for 8B mirrors: 72" x 47-1/2"

**** Framed mirrors are fabricated to a tolerance of (+/-) 1/8"

***** Mirrors conform to Federal Specifications DD-M-00411b & DDg-541D.

INSTALLATION

Coordinate installation with architect / contractor for specific mounting location and height for each mirror application. Making sure "I" bracket is level, transfer all mounting point locations to wall surface from drawing. Secure brackets with proper fasteners for each application. Slide mirror down over horizontal brackets until clip lock secures mirror in place. Mirror can only be removed by inserting tool through hole at bottom of frame depressing clip. This will allow mirror to slide up over brackets. Fillers are available if mirrors are mounted above and below tile line. (U004 Filler) filler material will match mirror frame to form a one piece construction.

To meet ADA Code, bottom edge of reflective surface can be no higher than 40" above finished floor. (4.19.6) Full length mirrors may be used for universal application when installed in correct locations.

Abrasive cleaners & chloric solutions should not be used on mirrors. Discoloring and /or scratching of frame and reflective surface may occur.

NOTES

JOB #:

ITEM #:

QUANTITY:

Mounting	Hanging	Type	Size	Other

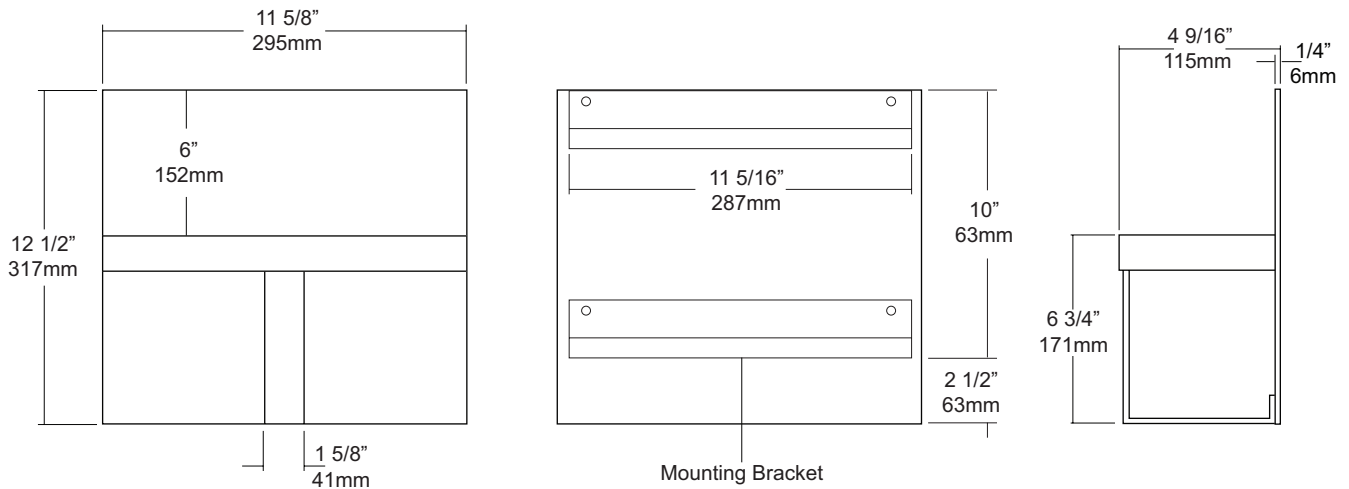

SPECIFICATIONS

Back Plate: Fabricated of #18 ga. stainless steel with a #4 satin finish.
Holding Straps: Fabricated of #16 ga. stainless steel and finished to match rest of unit.
Hangers: Fabricated of #22 ga. stainless steel.
Overall Size: 11 5/8"W x 12 1/2"H x 4 9/16"D
305mm x 279mm x 103mm
Capacity: One (1) standard bedpan

INSTALLATION

Place rack on wall surface making sure unit is level, transfer mounting point locations. Drill pilot holes and secure with proper fasteners per each application. (Fasteners not included)

NOTES



UG3-A

Grab Bars

Revised 03/11

JOB #:

ITEM #:

QUANTITY:

MOUNTING	HANDING	TYPE	SIZE	OTHER

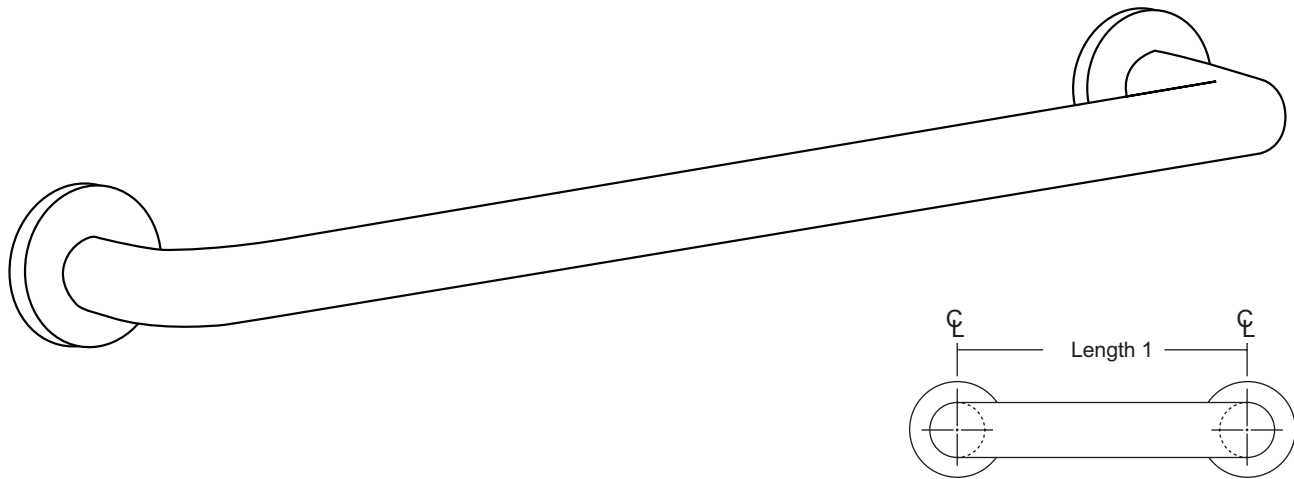

SPECIFICATIONS & INSTALLATION

Tubing: Fabricated of #18 ga stainless steel with a #4 satin finish. Available in 1 1/2" outside diameter. All bends are formed by an automatic mandrel bending process. All bars maintain a constant 1 1/2" offset.

Finish: Standard finish is a #4 satin finish. For a non-slip finish (peened) add suffix X to model number. (Ex. UG3X-A)

Flanges: Snap flanges are fabricated of 3" diameter, 3/8" deep drawn #22 ga stainless steel with #4 satin finish to match tubing. Flanges have dimples that secure over mounting plate.

Strength: Bars with a 1 1/2" offset clearance will support loads in excess of 900lbs when properly installed. Bars with greater offsets will support loads up to 250lbs when properly installed.

Installation: Before installing grab bars, verify with all state and local codes for requirements on bar diameter and type finish. Recommended mounting heights for grab bars are 33" - 36" centerline above finished floor. All mounting of grab bars when possible should have in wall mounting back plates. Find centerline mounting points and place bar on line making sure to be on center. Transfer mounting points (3 per flange) to wall. Drill pilot holes and secure bar with proper anchors per application. Snap cover over mounting plate.

Standard Lengths (Other sizes available upon request): 12", 16", 18", 24", 30", 32", 36", 42", 48", 50", 52", 54", 56"

FLANGE INFORMATION

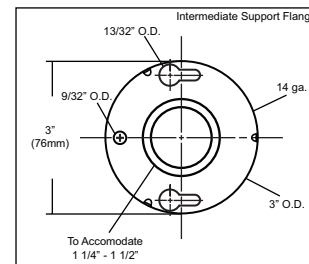
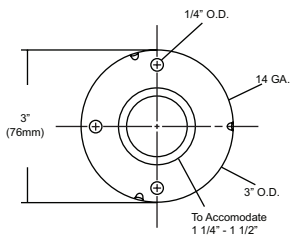
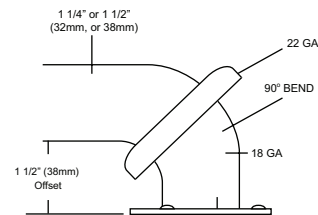

NOTES



UX110-BF

Single Robe Hook

Revision 03/11

JOB #:

ITEM #:

QUANTITY:

MOUNTING	HANDING	TYPE	SIZE	OTHER

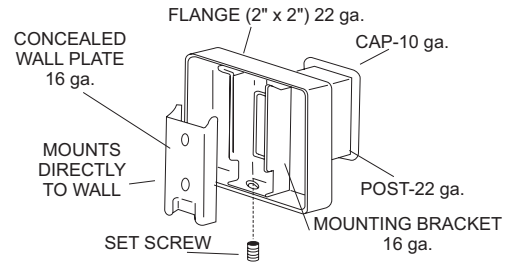
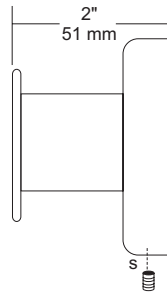
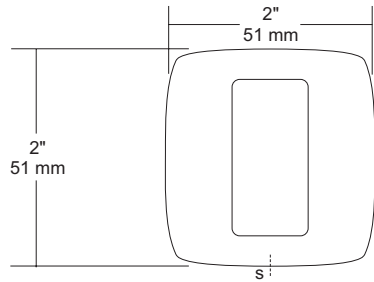

SPECIFICATIONS

UX Accessories: All UX bath accessories series are fabricated of stainless steel with a bright or satin finish. Mounting plates are concealed with a snap-on type plate secured by a set screw.

Hook: #10 ga stainless steel hook.

Flange: 2" x 2" flange #22 ga stainless steel.

Post: #22 ga stainless steel.

Mounting Plate: #16 ga concealed wall plate. Set screw secures mounting plate and flange.

Overall Size: 2"W x 2"H x 1 5/8"D

51mm x 51mm x 41mm

UX110-SF: Same as UX110-BF with satin finish

INSTALLATION

Provide an area on wall surface at desired or specified location. Place concealed mounting plate on wall surface and transfer mounting points. Drill pilot holes and secure with proper fasteners. Place snap on flange over plate and secure with set screw.

NOTES