

date
projectname
attn
from
fax
email
phone

1-27-2017
UHN Mez Fit Out
Joanie Keller
John Olszewski
724-693-8766
john@olszewskisales.com
724-693-2666



U126 Soap Dispenser

Revision 11/14

JOB #:

ITEM #:

QUANTITY:

MOUNTING	HANDING	TYPE	SIZE	OTHER



SPECIFICATIONS

Soap Tank: Fabricated of #20 ga stainless steel, #4 satin finish, fully welded one-piece construction.

Valve: All purpose antibacterial soap valve cylinder, black molded plastic push style valve that takes less than 5 lbs of force and one hand to operate complies with barrier free guidelines when mounted at proper height.

Viewer: Clear plastic window allows a constant fluid level check.

Concealed Mounting Plate: Fabricated of heavy gauge stainless steel.

Filler Cap: Fabricated of stainless steel, hinged to allow easy servicing, secured with special key that creates a vandal resistant dispenser.

Overall Size: 4 3/4"W x 8 1/4"H x 3 3/4"D (wall to valve)

121mm x 210mm x 95mm

Capacity: 40 oz.

Recommend type soaps without chloric solutions for proper operation.

INSTALLATION

Provide an area on mounting surface at desired or specified location. Secure concealed mounting plate to wall surface with proper fasteners. Slide dispenser down over mounting plate and secure by means of set screw located inside tank. Fill unit with proper soap. Close lid and secure with special key. Test valve for proper operation.

*It is not recommended to mount any soap dispenser on mirrors

**For best performance, use pre-mixed low concentrate solutions. Dispensers should have periodic maintenance performed to insure the life dispenser. Rinse out globe and valve with warm water to avoid sludge buildup.

Preventative Maintenance: Each dispenser should be flushed out aprx. Every 30 days with warm water to prevent valve from clogging with old soap. Do not use abrasive cleaners to clean dispenser.

NOTES



U526-SM

Surface Mounted Sanitary Napkin & Tampon Dispenser

Revision 03/11

JOB #:

ITEM #:

QUANTITY:

MOUNTING	HANDING	TYPE	SIZE	OTHER

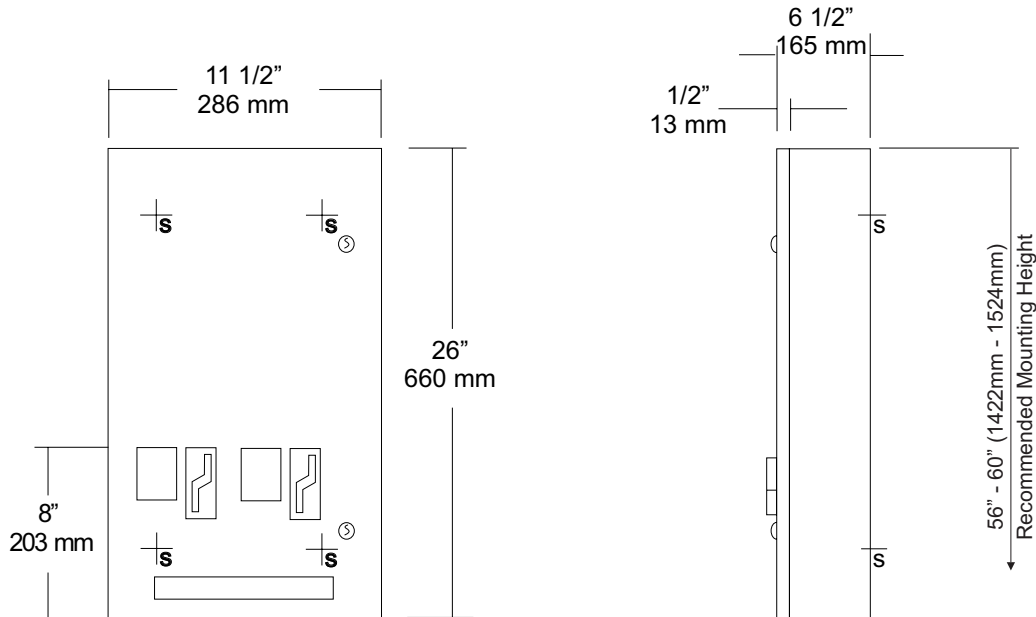

SPECIFICATIONS

Door: Fabricated of #18 ga stainless steel with #4 satin finish. Door has 1/2" returns for rigidity.

Body: Fabricated of #22 ga stainless steel with a #4 satin finish.

Coin Mechanisms: Two independent, trouble free turn knob mechanisms, with an "EMPTY" indicator that does not allow coins to be inserted into mechanism when product has been depleted. Operational with one hand with less than 5 lbs of force without tight grasping. Can be operated with palm, elbow or forearm if user has a physical impairment. (Free, .5, .10, .25, .50)

Hinges: Full length, heavy duty, stainless steel piano type hinge.

Locks: Pin tumbler, commercial quality, keyed like all other AJW cabinets. *(Coin box keyed differently then the door for security)

Overall Size: 11 1/2"W x 26"H x 6 1/2"D

292mm x 660mm x 165mm

Capacity: Napkins: 30, Tampons: 27

Verify Coinage: Napkin _____ Tampon _____

Recommended Package Sizes:

Napkins:

Min: 2 5/8"W x 4 1/8"L x 3/4"H

Max: 3 1/8"W x 4 1/2"L x 1 1/8"H

Tampons:

Min: 5/8" Dia. x 4 1/4"L

Max: 3/4" Dia. 5 1/8"L

INSTALLATION

Coordinate installation with architect or contractor to avoid interference with pipes, vents, etc. Open cabinet and transfer mounting points to wall surface after location is verified. Drill pilot holes and secure with proper fasteners per each application. Fill each chute with the proper products and make certain to place weights on the top product. Test operation of mechanism and dispensing of product before securing cabinet. Each cabinet comes with a parts list for ordering replacement parts if ever required.

*Note: Adjustable flange can be added to make unit Semi-Recessed. When mounted properly, unit will comply with ADA Code 4.27.4

NOTES

Formerly Model #: U527



U582
Surface Mounted Sanitary Napkin
Disposal
Revision 03/11

JOB #:
ITEM #:
QUANTITY:

MOUNTING	HANDING	TYPE	SIZE	OTHER

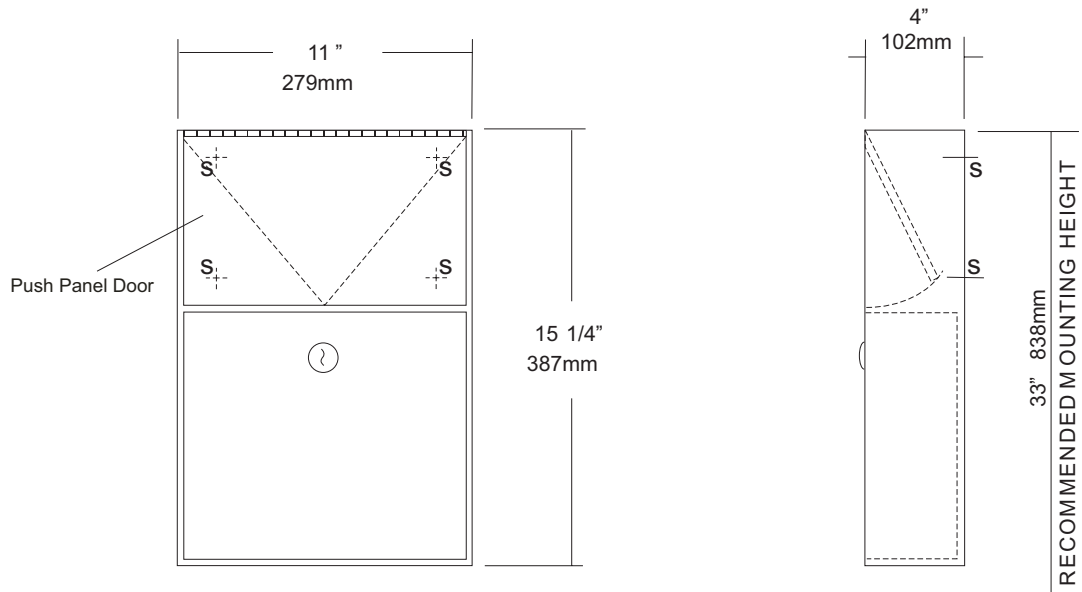

SPECIFICATIONS

Cabinet Body: Fabricated of #22 ga stainless steel #4 satin finish,
Push Panel: Fabricated of #22 ga stainless steel self closing push panel. International graphic symbols are optional.
Waste: #22 ga stainless steel removable type waste secured by a pin tumbler lock. Optional finger grip in lieu of lock is available.
Locks: Pin tumbler commercial quality locks keyed like all other AJW cabinets,
Hinge: Full length, heavy duty, stainless steel piano type hinge,
Overall Size: 11"W x 15 1/4"H x 4"D
279mm x 387mm x 102mm
Capacity: 1.5 gallons (.2 cu ft.)
NDL-13-50: Waxed disposable liners. (50 per Case)
OPTIONS:
-PW: Rigid plastic waste insert
-IGS: International Graphic Symbol

INSTALLATION

Provide an area on wall surface at desired or specified location. Place unit on wall and verify unit is level. Transfer mounting point locations and drill pilot holes. Remove waste can and secure to wall surface with proper fasteners for each application.

NOTES

MOUNTING	HANDING	TYPE	SIZE	OTHER
----------	---------	------	------	-------

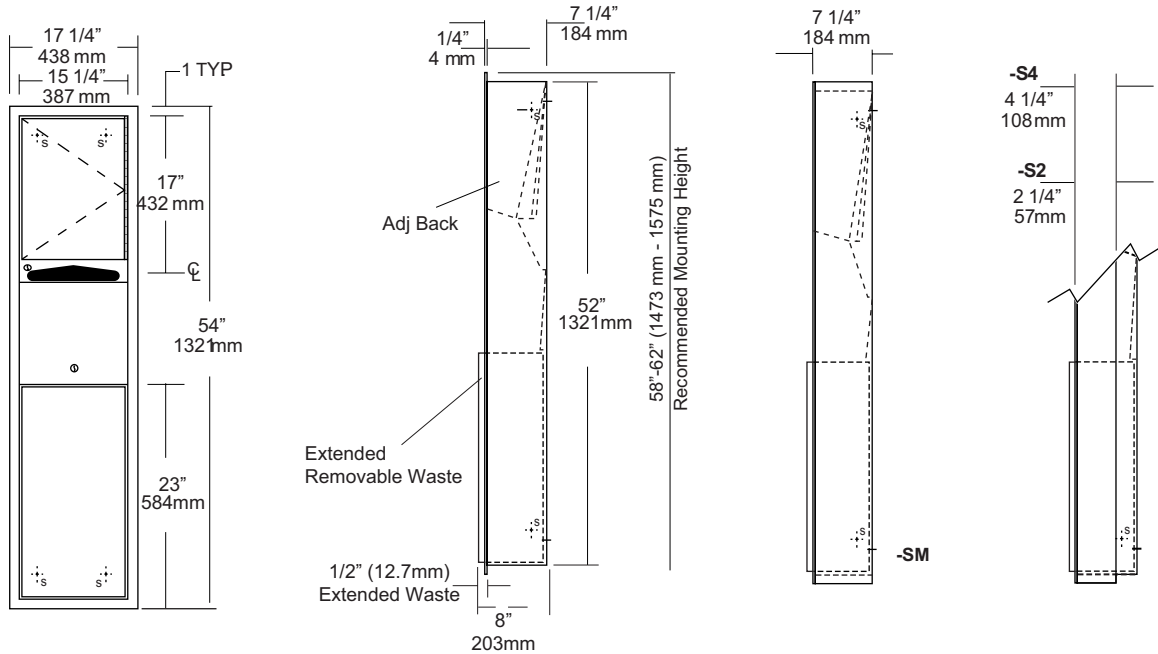

SPECIFICATIONS

Body: Fabricated of #22 ga stainless steel with a #4 satin finish.

Flange: Fabricated of #22 ga stainless steel finished to match cabinet with 1/4" returns. (No miters or welds)

Cabinet Back: Fabricated of stainless steel formed for rigidity with multiple welds to cabinet body.

Cabinet Door: Fabricated of #22 ga stainless steel with #4 satin finish.

Towel Dispenser: Dispensing area has hemmed edges to prevent injury and towel tearing. Adjustable back allows c-fold and single-fold towels to be dispensed.

Removable Waste: #22 ga stainless steel #4 satin finish with all leading edges to have a radius. Unit is secured in place by a bottom bracket guide and top lock.

Hinge: Full length, heavy duty, stainless steel piano type hinge.

Locks: Pin tumbler commercial quality, keyed like all other AJW cabinets.

Collars: Fabricated of #22 ga stainless steel, finished to match cabinet. (Used when full recessing cannot be accomplished)

Overall Size: 17 1/4"W x 54"H x 8"D (wall depth req)
438mm x 1372mm x 203mm

Wall Opening: 15 3/4"W x 52 1/2"H x 7 1/2"D
400mm x 1334mm

U653-S2: semi-recessed. with 2" collar, 5 1/2" wall opening 139mm

U653-S4: semi-recessed. with 4" collar, 3 1/2" wall opening 88mm

U653-SM: Full surface mounted collar.

Towel Capacity: 600 c-fold, 800 multifold, 1200 singlefold

Waste Capacity: 12 gallons (1.6 cu ft)

Options:

- VL1: Reusable vinyl liner

INSTALLATION

Coordinate installation with architect and contractor to avoid interference with pipes, vents, etc. Provide a rough wall opening 15 3/4"W x 52 1/2"H. See chart for required wall depth. If collar is required, slide collar over the back before installing into wall. Remove waste from cabinet and mount unit plumb and true in opening with proper fasteners per application. Secure waste in cabinet and load paper towels.

When cleaning cabinet use a non abrasive non-chloric solution and wiped off with the grain of the cabinet.

NOTES

JOB #:

ITEM #:

QUANTITY:

MOUNTING	HANDING	TYPE	SIZE	OTHER

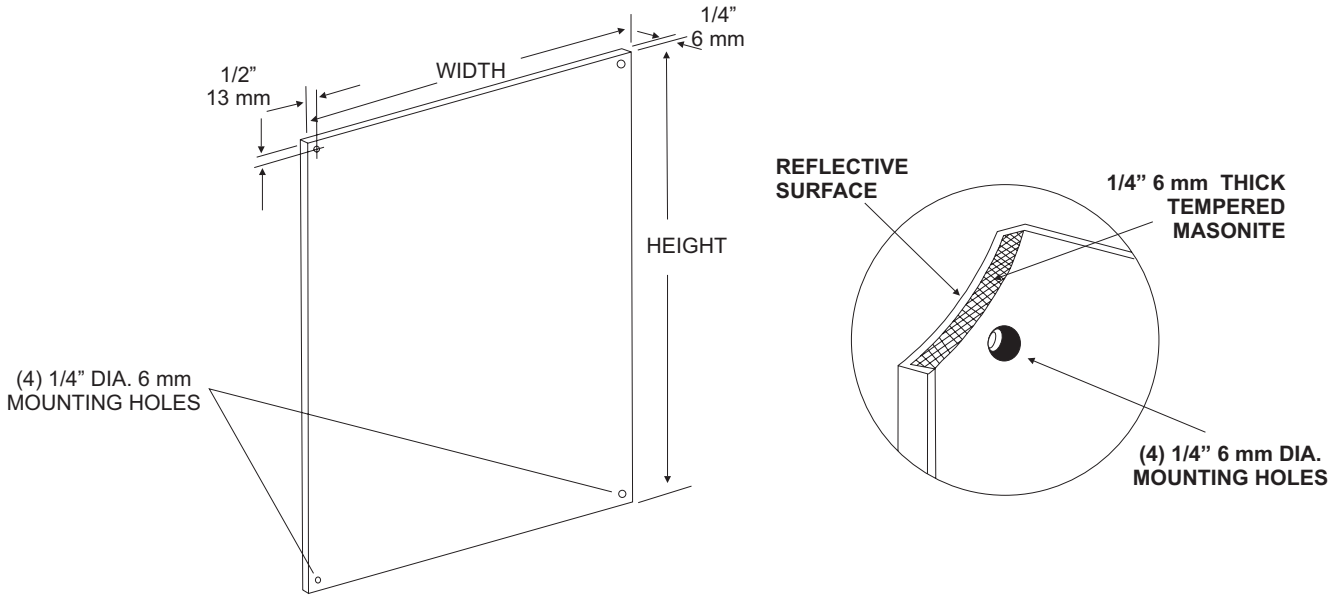

SPECIFICATIONS

Mirror: Type 304 #20 ga stainless steel with #8B architectural finish. Both mirrors have 1/4" returns to wall surface for rigidity surrounding 1/4" thick tempered masonite backing. 1/4" diameter exposed mounting points are provided. Each mirror is shipped with a removable vinyl protective coating.

Note: Stainless steel mirrors reflect images in different optic quality than plate glass. There will be a slight distortion which increases proportionately with the mirror size. Therefore we cannot be held responsible for quality of image.

Cleaning: Non-abrasive and non-chloric solutions should be used to clean stainless steel mirrors.

These Mirrors are always ordered Width x Height

INSTALLATION

Provide an area at desired or specified location and strike a line that is level. Place mirror at this line and check again with level. Transfer mounting locations to wall surface and drill pilot holes. Peel off vinyl coating around corners only before securing to wall. Secure mirror with proper fasteners per each application. Do not over tighten fasteners. If a depression is formed by over-tightening the reflective quality may be affected. Remove remainder of vinyl coating after mirror checks with level and is properly secured. The bottom reflective surface edge must be mounted 40" above finished floor to comply with ADA code, 4.19.6.

NOTES



U840 Toilet Tissue Dispenser

Revision 03/11

JOB #:

ITEM #:

QUANTITY:

MOUNTING	HANDING	TYPE	SIZE	OTHER

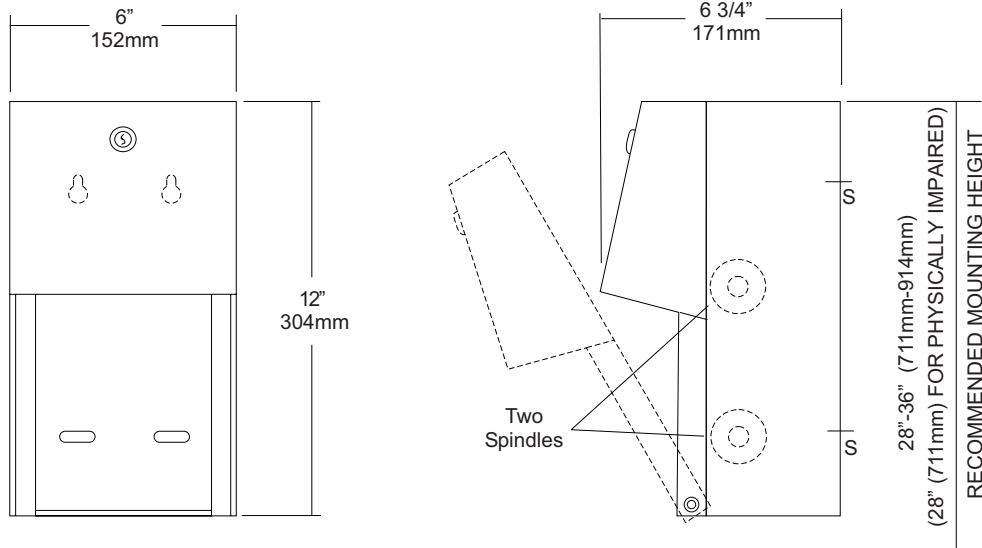

SPECIFICATIONS

Body: Fabricated of #22 ga stainless steel with #4 satin finish. Concealed inner dispensing mechanism is #18 ga stainless steel.

Back: Fabricated of #18 ga stainless steel with multiple welds to cabinet body forming a one piece construction.

Hood: Fabricated of #18 ga stainless steel finished to match cabinet body. Hood is secured with stainless steel hinge rivets to cabinet body. Top roll of tissue will not drop down unless the bottom roll has been depleted. When unit is closed, this will provide a theft resistant, non-control operation and reduce vandalism.

Locks: Pin tumbler, commercial quality locks keyed like all other AJW cabinets.

Spindles: (U005) Fabricated of one-piece molded high impact black ABS material.

Overall Size: 6"W x 12"H x 6 3/4"D

152mm x 305mm x 171mm

Capacity: Two standard rolls with a 5 1/4" (133mm) OD..

INSTALLATION

Provide an area on mounting surface at desired or specified location. Open cabinet, remove spindles and hold unit to wall at desired location. Transfer mounting points and drill pilot holes. Secure unit with proper fasteners per each application. Load toilet tissue on rollers, place in concealed track and close hood. Raise lower roll against upper and take hand away. Lower roll should fall into place with upper roll remaining up above the hood line. If loaded properly, top roll will not fall for use until bottom roll has been depleted. When servicing dispenser, full rolls must be used on both spindles to insure proper operation.

All toilet tissue dispensers that meet ADA code cannot have any type of control delivery. (4.16)

NOTES

Formerly Model #: U840A



UG3-A

Grab Bars

Revised 03/11

JOB #:

ITEM #:

QUANTITY:

MOUNTING	HANDING	TYPE	SIZE	OTHER



SPECIFICATIONS & INSTALLATION

Tubing: Fabricated of #18 ga stainless steel with a #4 satin finish. Available in 1 1/2" outside diameter. All bends are formed by an automatic mandrel bending process. All bars maintain a constant 1 1/2" offset.

Finish: Standard finish is a #4 satin finish. For a non-slip finish (peened) add suffix X to model number. (Ex. UG3X-A)

Flanges: Snap flanges are fabricated of 3" diameter, 3/8" deep drawn #22 ga stainless steel with #4 satin finish to match tubing. Flanges have dimples that secure over mounting plate.

Strength: Bars with a 1 1/2" offset clearance will support loads in excess of 900lbs when properly installed. Bars with greater offsets will support loads up to 250lbs when properly installed.

Installation: Before installing grab bars, verify with all state and local codes for requirements on bar diameter and type finish. Recommended mounting heights for grab bars are 33" - 36" centerline above finished floor. All mounting of grab bars when possible should have in wall mounting back plates. Find centerline mounting points and place bar on line making sure to be on center. Transfer mounting points (3 per flange) to wall. Drill pilot holes and secure bar with proper anchors per application. Snap cover over mounting plate.

Standard Lengths (Other sizes available upon request): 12", 16", 18", 24", 30", 32", 36", 42", 48", 50", 52", 54", 56"

FLANGE INFORMATION

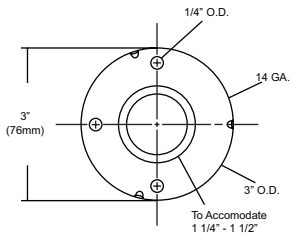
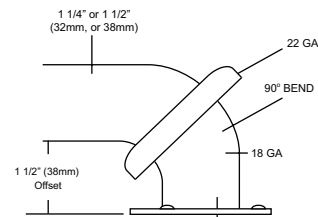

NOTES