

date
projectname
attn
from
fax
email
phone

1/2/3
a
Andrew Cassman



U944

Baby Changing Station

Revision 11/14

JOB #:

ITEM #:

QUANTITY:

MOUNTING	HANDING	TYPE	SIZE	OTHER
----------	---------	------	------	-------

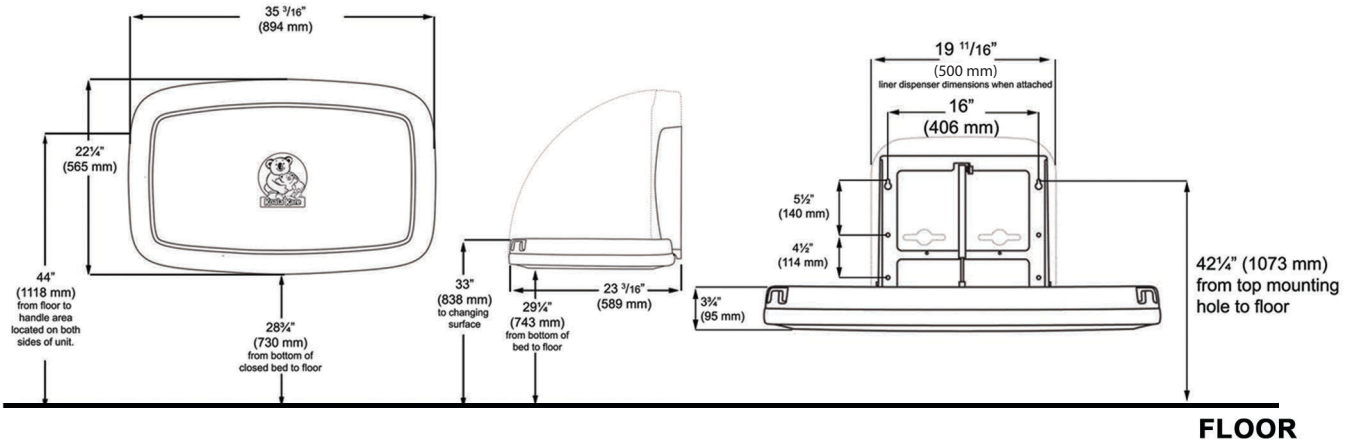

FLOOR

SPECIFICATIONS

Body: FDA approved injection molded polypropylene with Microban antimicrobial additive. Reinforced steel-on-steel hinge mechanism and metal mounting chassis. Labeled usage instructions and safety messages in four languages.

Liner Dispenser: An integral part of body that is standard with each unit. (Capacity: 50)

Pneumatic Cylinder: Concealed pneumatic cylinder & hinge structure provides controlled and smooth open and close motion.

Safety Straps: Nylon safety strap snap lock fastens to hold child securely in place.

Overall Size: 35 3/16"W x 22 1/4"H x 4"D (closed) 23 3/16"D (open)

894mm x 565mm x 102mm (closed), 589mm (open)

Available Colors: Cream & Grey

Optional Braille Label (Not included)

INSTALLATION

Coordinate installation with architect or contractor to avoid interference with surrounding objects. Hold unit up to wall and open to verify there are no obstructions to interfere with operation of station. From finished floor to the top of the unit closed should be at a height of 48". Transfer mounting point locations to wall surface and drill pilot holes. Secure unit with proper fasteners for each application. (Recommend a qualified carpenter to install unit) Unit can be lowered with one hand and into position with less than 5 lbs of force, wall opening turning or twisting of wrist. Verify with local codes and type approach (forward or side) for proper mounting height above finished floor. Unit can support up to 200lbs when properly installed.

Unit should be cleaned once or more daily with a clean nylon brush and spray disinfectant.

When properly installed, baby changing stations comply with ASTM static load performance requirements.

NOTES

Formerly Model #: U945H