

date
projectname
attn
from
fax
email
phone

8/16/2018
PS398Q
Amy

myah@alissco.com

JOB #:

ITEM #:

QUANTITY:

MOUNTING	HANDING	TYPE	SIZE	OTHER

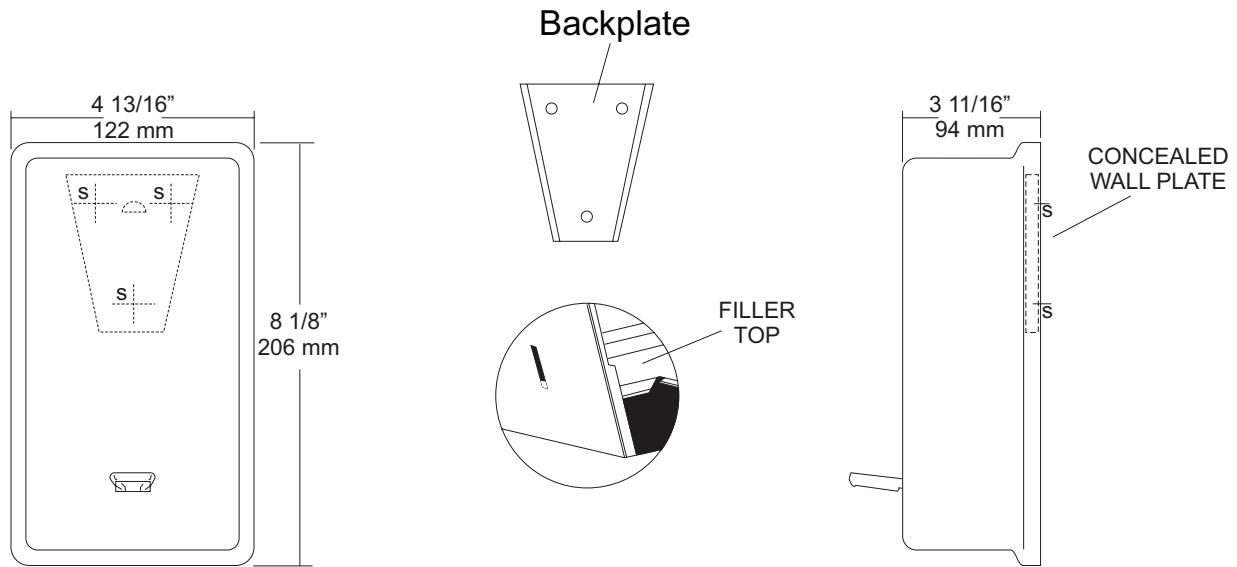

SPECIFICATIONS

Tank: Fabricated of #22 gauge stainless steel, formed construction. Back and tank are fully welded to form a one piece unit. Large filler cap is tamper resistant that opens with special key. Large opening allows easy servicing.

Concealed Wall Plate: Fabricated of heavy gauge stainless steel.

Valve: Stainless steel agitator that is spring loaded and adjustable to regulate the amount of soap to be dispensed. Caking of powdered soap is avoided because moisture cannot enter dispenser.

Overall Size: 4 13/16"W x 8 1/8"H x 3 11/16"D

121mm x 206mm x 93mm

Capacity: 32 oz powder soap

INSTALLATION

Provide an area on wall surface at desired or specified location. Place concealed mounting plate on wall surface and transfer mounting points. Drill pilot holes and secure with proper fasteners per application. Secure tank to mounting plate by opening filler cap and tightening down lock screw. Fill tank with powder soap. Test powder for dispensing and adjust to required flow.

*It is not recommended to mount any soap dispenser on mirrors

NOTES

JOB #:

ITEM #:

QUANTITY:

MOUNTING	HANDING	TYPE	SIZE	OTHER

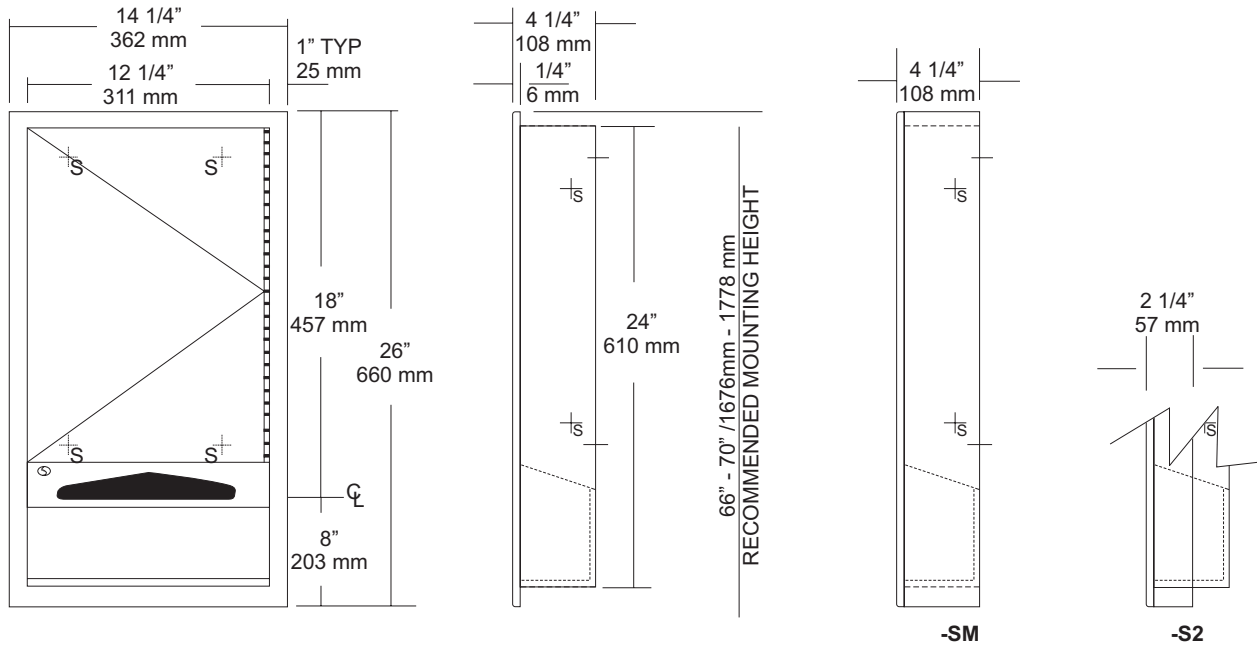

SPECIFICATIONS

Cabinet Body: Fabricated of #22 ga stainless steel. Face trim is an integral part of body with a #4 satin finish and 1/4" returns to wall surface for rigidity. One piece construction without miters or welds.

Cabinet Door: Fabricated of #22 ga stainless steel with a #4 satin finish. Full length door stops protect door from vandalism.

Cabinet Back: Fabricated of #22 ga stainless steel with multiple welds to cabinet body:

Towel Dispensing: Hemmed edges that prevent injury and towel tearing.

Hinges: Heavy duty, full length, stainless steel piano type hinge secured door to cabinet.

Lock: Commercial quality, pin tumbler type lock keyed like all other AJW accessories.

Collars: Fabricated of #22 ga stainless steel finished to match cabinet for surface or recess mounting.

Overall Size: 14 1/4"W x 26"H x 4 1/4"D
362mm x 660mm x 108mm

Wall Opening: 12 3/4"W x 24 1/2"H x 4"D
324mm x 622mm x 102mm

U230-S2: 2" semi-recessed collar, 2" wall opening 51mm.

U230-SM: Full surface mounted collar.

Capacity: 600 c-fold or 800 multifold Towels

INSTALLATION

Coordinate installation with architect and contractor to avoid interference with pipes vents etc. in wall. Provide a rough wall opening 12 3/4"W x 24 1/2"H. See specification for proper wall depth opening. Open cabinet and insert into wall opening. Secure with proper fasteners per each application. Fill unit with recommended towels, without overfilling. Make sure towels overlap each other so they will be available each time a towel is removed from dispensing area. Do not use abrasive or chloric solutions when cleaning cabinet.

NOTES

U705 Series Angle Frame Mirror & Shelf

Revision 11/15

JOB #:

ITEM #:

QUANTITY:

MOUNTING	HANDING	TYPE	SIZE	OTHER

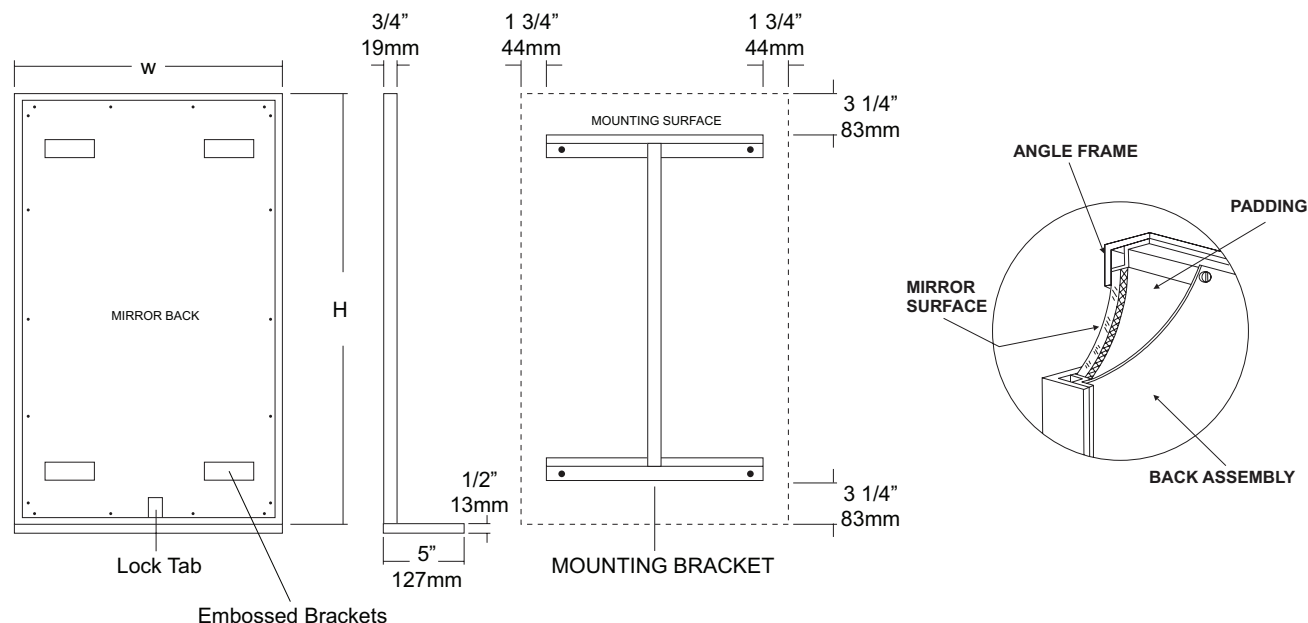

SPECIFICATIONS

Frame: Fabricated of #18 ga stainless steel, #4 satin finish. 3/4" x 3/4" frame with welded mitered corners are ground and polished smooth. #22 ga concealed "Z" channel is spot welded to frame for greater rigidity.

Mirror: 1/4" thick type 1 transparent flat type, class 1 - clear glass mirrors. Mirror is coated with silver and sealed with a uniform electrolytic copper plating, along with two coats of paint for added protection. Mirrors are guaranteed against silver spoilage for a period of 15 years. Mirrors conform to ASTM C1036 and ASTM C1503-R8.

Shelf: #18 ga stainless steel with #4 satin finish. Shelf is 5"D x full width of mirror. All edges are turned down 1/2" with front edge turned back 1/2" for rigidity and prevents possible injury. #18 ga support bracket is welded to both frame and shelf then ground smooth.

Filler: 3/16" thick full size, shock absorbing, water resistant, non-abrasive polyethylene padding protects all concealed mirror surfaces.

Back: #20 ga pre-plated galvanized steel, with embossed horizontal louver mounting brackets. Embossed theft resistant pressure activated clip lock device, locks mirror in place to wall hangers.

Hangers: Fabricated of #20 ga pre-plated galv. steel.

Standard Sizes Available (W x H): 16"x24", 16"x30", 18"x24", 18"x30", 18"x36", 24"x30", 24"x36"

Options:

LG: Laminated Glass

LX: Polycarbonate

PM: Plastic Acrylic

T: Tempered Glass

VC: Vinyl Clad (Safety Glass)

8B: #8 Reflective Stainless Steel

*Stainless steel mirrors reflect images in different optic quality than plate glass. There will be a slight distortion which increases proportionately with the mirror size. Therefore, AJW Architectural Products™ cannot be held responsible for quality of image.

**Mirrors are always ordered Width x Height

***Recommended max size for 8B mirrors: 72" x 47'-1/2"

****Framed mirrors are fabricated to a tolerance of (+/-) 1/8"

***** Mirrors conform to Federal Specifications DD-M-00411b & DD-g-541D

INSTALLATION

Coordinate installation with architect / contractor for specific mounting location and height for each mirror application. Making sure "I" bracket is level, transfer all mounting point locations to wall surface from drawing. Secure brackets with proper fasteners for each application. Slide mirror down over horizontal brackets until clip lock secures mirror in place. Mirror can only be removed by inserting tool through hole at bottom of frame depressing clip. This will allow mirror to slide up over brackets. Fillers are available if mirrors are mounted above and below tile line. (U004 Filler) filler material will match mirror frame to form a one piece construction.

To meet ADA Code, bottom edge of reflective surface can be no higher than 40" above finished floor. (4.19.6) Full length mirrors may be used for universal application when installed in correct locations.

Abrasive cleaners & chloric solutions should not be used on mirrors. Discoloring and /or scratching of frame and reflective surface may occur.

NOTES