

date  
projectname  
attn  
from  
fax  
email  
phone

01/11/22  
Piper Square Apartments  
Billy Keller  
Nate Kain  
804-789-1489  
nkain@hanoverspecialties.com  
804-789-1088



# U704 Series

## Fixed Tilt Angle Frame Mirror

Revision 11/15

JOB #:

ITEM #:

QUANTITY:

MOUNTING	HANDING	TYPE	SIZE	OTHER

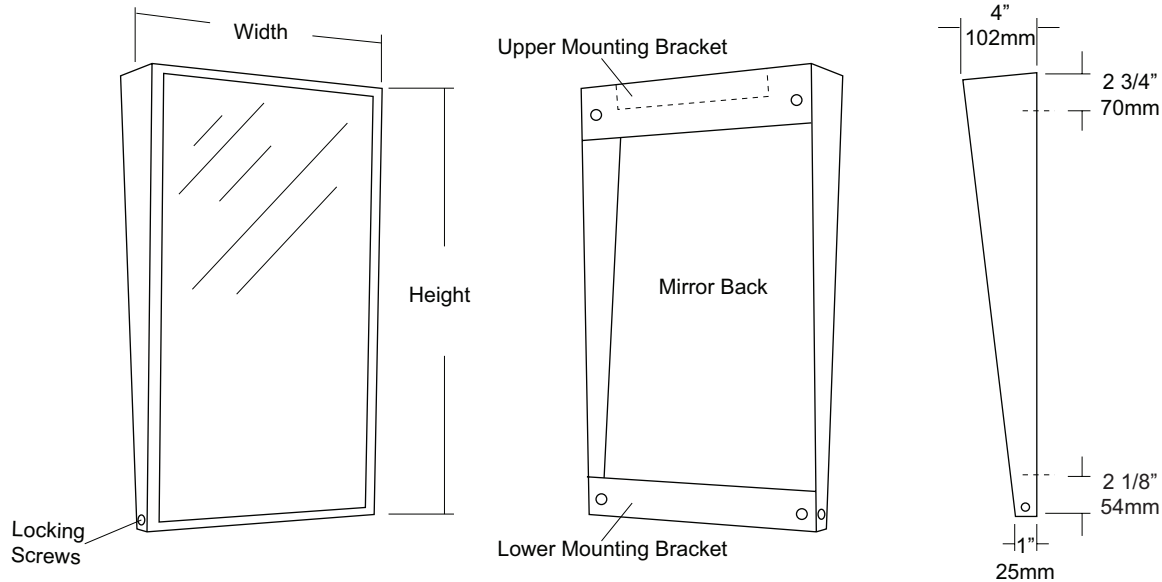

### SPECIFICATIONS

**Frame:** Fabricated of #18 ga stainless steel, #4 satin finish. Stainless steel frame is fabricated with welded mitered corners that are ground and polished smooth. Mirror extends out 4" at top and tapers to 1" at bottom.

**Mirror:** 1/4" thick type 1 transparent flat type, class 1 - clear glass mirrors. Mirror is coated with silver and sealed with a uniform electrolytic copper plating, along with two coats of paint for added protection. Mirrors are guaranteed against silver spoilage for a period of 15 years. Mirrors conform to ASTM C1036 and ASTM C1503-R8.

**Filler:** 3/16" thick full size, shock absorbing, water resistant, non-abrasive polyethylene padding protects all concealed mirror surfaces

**Brackets:** Mounting brackets are fabricated of #20 ga pre-plated, galvanized steel. Lower bracket has two (2) side mounting points that allow frame to be secured to bracket.

**Standard Sizes Available (W x H):** 16"x24", 16"x30", 18"x24", 18"x30", 18"x36", 24"x30", 24"x36"

**Options:**

**LG:** Laminated Glass

**LX:** Polycarbonate

**PM:** Plastic Acrylic

**T:** Tempered Glass

**VC:** Vinyl Clad (Safety Glass)

**8B:** #8 Reflective Stainless Steel

\*Stainless steel mirrors reflect images in different optic quality than plate glass. There will be a slight distortion which increases proportionately with the mirror size. Therefore, AJW Architectural Products™ cannot be held responsible for quality of image.

\*\* Mirrors are always ordered Width x Height

\*\*\* Recommended max size for 8B mirrors: 72" x 47-1/2"

\*\*\*\* Framed mirrors are fabricated to a tolerance of (+/-) 1/8"

\*\*\*\*\* Mirrors conform to Federal Specifications DD-M-00411b & DD-g-541D

### INSTALLATION

Coordinate installation with architect / contractor for specific mounting location and height for each mirror application. Check all state and local codes for installation requirements. Remove hanger brackets and transfer mounting points to wall surface. Secure with proper fasteners for each application. Slide mirror frame over brackets and secure in place. Secure frame to bracket. Fillers are available if mirrors are mounted above and below tile line. (U004 Filler) Filler material will match mirror frame to form a one piece construction.

To meet ADA Code, bottom edge of reflective surface can be no higher than 40" above finished floor. (4.19.6) Full length mirrors may be used for universal application when installed in correct locations.

Abrasive cleaners & chloric solutions should not be used on mirrors. Discoloring or scratching may occur on frame and reflective surface.

### NOTES

JOB #:

ITEM #:

QUANTITY:

MOUNTING	HANDING	TYPE	SIZE	OTHER

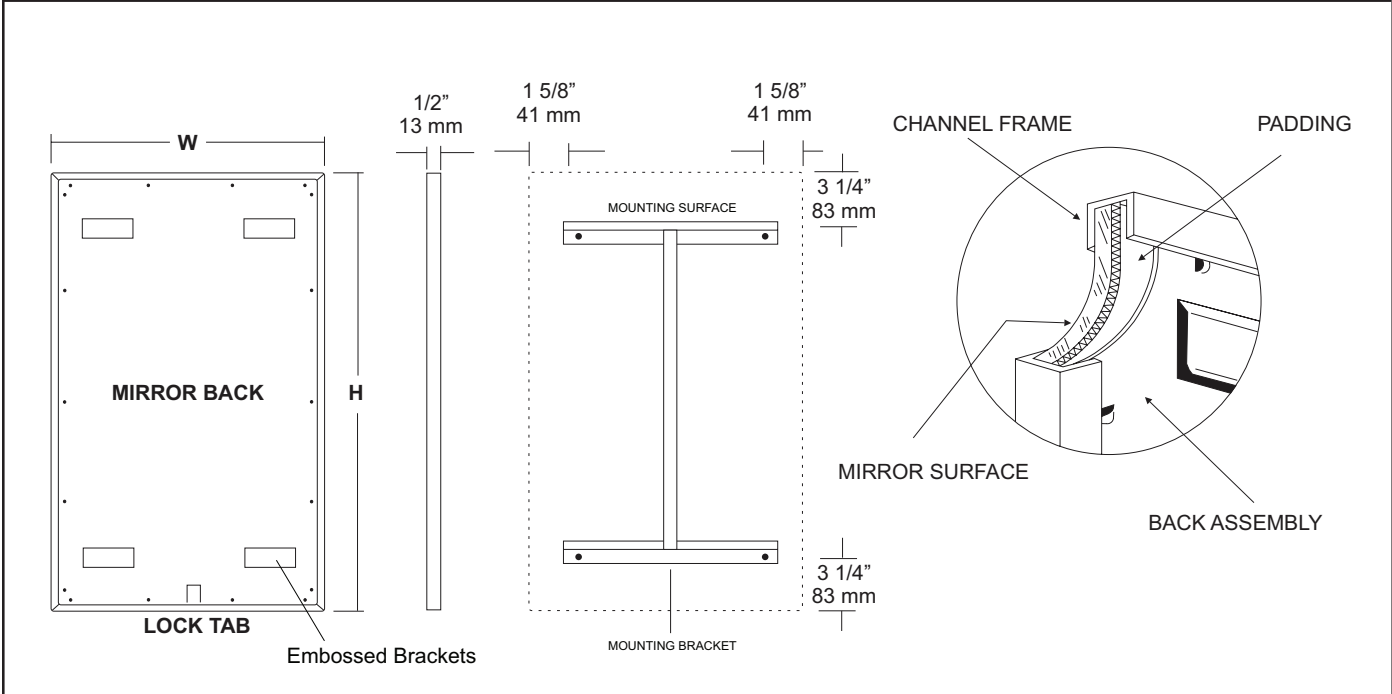

#### SPECIFICATIONS

**Frame:** Fabricated of #20 ga stainless steel, #4 satin finish. Roll formed 1/2" x 1/2" x 1/2" channel frame has mitered corners and secured with stainless steel rivet.

**Mirror:** 1/4" thick type 1 transparent flat type, class 1 - clear glass mirrors. Mirror is coated with silver and sealed with a uniform electrolytic copper plating, along with two coats of paint for added protection. Mirrors are guaranteed against silver spoilage for a period of 15 years. Mirrors conform to ASTM C1036 and ASTM C1503-R8.

**Filler:** Full size, 1/8" shock absorbing, water resistant, nonabrasive, polyethylene padding protects all concealed mirror surfaces.

**Back:** #20 ga pre-plated galvanized steel, with embossed horizontal louver mounting brackets. Embossed theft resistant pressure activated clip lock device, locks mirror in place to wall hangers.

**Hangers:** Fabricated of #20 ga pre-plated steel galvanized steel with mounting points.

**Standard Sizes Available (W x H):** 16"x20", 16"x24", 16"x30", 18"x24", 18"x30", 18"x36", 24"x30", 24"x36", 24"x42", 24"x48", 18"x60", 20"x60", 24"x60", 18"x72", 24"x72"

#### Options:

- LG:** Laminated Glass
- LX:** Polycarbonate
- PM:** Plastic Acrylic
- T:** Tempered Glass
- VC:** Vinyl Clad (Safety Glass)
- 8B:** #8 Reflective Stainless Steel

\*Stainless steel mirrors reflect images in different optic quality than plate glass. There will be a slight distortion which increases proportionately with the mirror size. Therefore, AJW Architectural Products™ cannot be held responsible for quality of image.

- \*\*Mirrors are always ordered Width x Height
- \*\*\*Recommended max size for 8B mirrors: 72" x 47-1/2"
- \*\*\*\*Framed mirrors are fabricated to a tolerance of (+/-) 1/8"
- \*\*\*\*\* Mirrors conform to Federal Specifications DD-M-00411b & DD-g-541D

#### INSTALLATION

Coordinate installation with architect / contractor for specific mounting location and height for each mirror application. Making sure "I" bracket is level, transfer all mounting point locations to wall surface from drawing. Secure brackets with proper fasteners for each application. Slide mirror down over horizontal brackets until clip lock secures mirror in place. Mirror can only be removed by inserting tool through hole at bottom of frame depressing clip. This will allow mirror to slide up over brackets. Fillers are available if mirrors are mounted above and below tile line. (U004 Filler) filler material will match mirror frame to form a one piece construction.

To meet ADA Code, bottom edge of reflective surface can be no higher than 40" above finished floor. (4.19.6) Full length mirrors may be used for universal application when installed in correct locations.

Abrasive cleaners & chloric solutions should not be used on mirrors. Discoloring and /or scratching of frame and reflective surface may occur.

#### NOTES



# U939

## Retractable Shower Bench

Revision 12/14

JOB #:

ITEM #:

QUANTITY:

MOUNTING	HANDING	TYPE	SIZE	OTHER

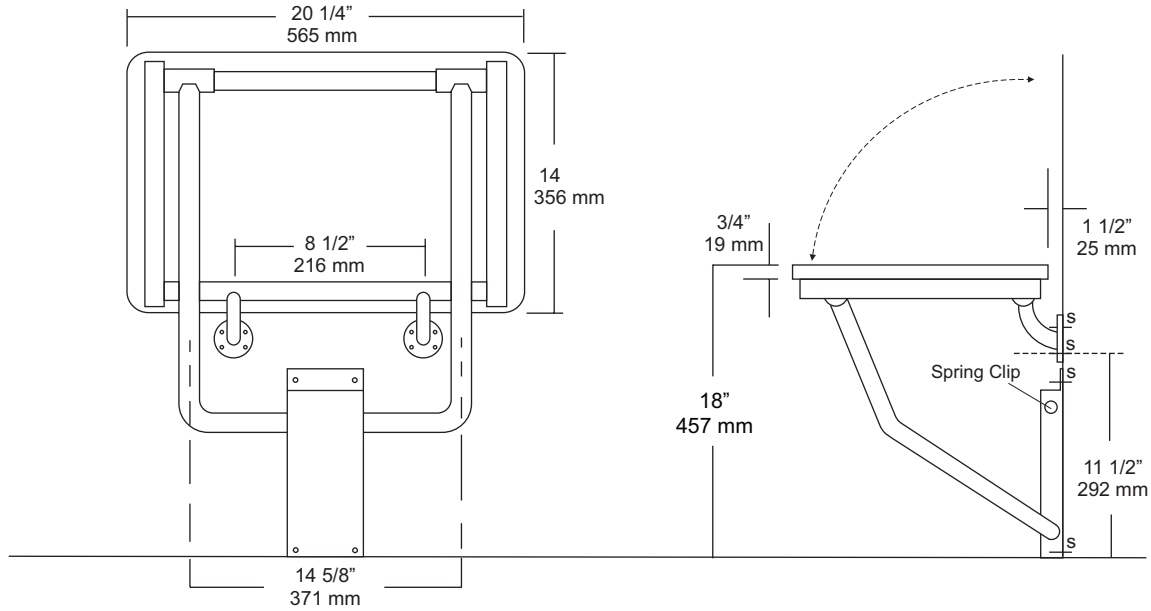

### SPECIFICATIONS

**Seat:** Fabricated of 3/4" thick, one piece polymers (white) with all leading edges having a radius to prevent injury. Seat is secured to frame with carriage bolts and acorn nuts.

**Tubing:** Fabricated of #18 ga stainless steel with #4 satin finish.

**Main Frame:** 1 1/4" diameter square tubing with capped ends.

**Flanges:** #18 gauge stainless steel with four (4) countersunk exposed mounting points. Under slung supports have a 1 1/4" OD. (Satin finish)

**Mounting Bracket:** #14 ga stainless steel "hat" style bracket with 4 mounting support points. Bracket acts as a guide to raise and lower seat platform and is equipped with four (4) points to secure to wall surface. For maximum support, bracket is mounted so the bottom is set on the finished floor surface. Seat will remain in an upright position when not in use by means of a spring clip.

**Overall Size:** 20 1/4"W x 14"D (seating area)

**514mm x 356mm**

**\*Wall to floor mounting design provides equal distribution of weight to ensure safe operation.**

### INSTALLATION

To comply with ADA Code, seat should be mounted at a height 17"-19" above finished floor. Check all state and local codes for building requirements. Recommend in wall mounting on all shower seats. (BP10) Place seat up against wall making sure the extended part of seat has an offset no more than 1 1/2" away from wall. (Same as grab bar) Transfer mounting points to wall surface and drill pilot holes. Secure seat to surface with proper fasteners per each application. Snugly secure seat to surface and check seat to be level. If seat is level raise and lower seat to check path of travel. Finish securing seat after checking seat for proper operation. When properly mounted seat will support up to 250 lbs and will conform with ADA Code 4.21.3 and 4.26.3

Note: This shower seat is not intended to be installed in applications that have shower bases with rounded corners. AJW recommends the U928 for such applications.

### NOTES

Formerly Model #: U939-1A



# UG3-A

Grab Bars

Revised 03/11

JOB #:

ITEM #:

QUANTITY:

MOUNTING	HANDING	TYPE	SIZE	OTHER



## SPECIFICATIONS & INSTALLATION

**Tubing:** Fabricated of #18 ga stainless steel with a #4 satin finish. Available in 1 1/2" outside diameter. All bends are formed by an automatic mandrel bending process. All bars maintain a constant 1 1/2" offset.

**Finish:** Standard finish is a #4 satin finish. For a non-slip finish (peened) add suffix X to model number. (Ex. UG3X-A)

**Flanges:** Snap flanges are fabricated of 3" diameter, 3/8" deep drawn #22 ga stainless steel with #4 satin finish to match tubing. Flanges have dimples that secure over mounting plate.

**Strength:** Bars with a 1 1/2" offset clearance will support loads in excess of 900lbs when properly installed. Bars with greater offsets will support loads up to 250lbs when properly installed.

**Installation:** Before installing grab bars, verify with all state and local codes for requirements on bar diameter and type finish. Recommended mounting heights for grab bars are 33" - 36" centerline above finished floor. All mounting of grab bars when possible should have in wall mounting back plates. Find centerline mounting points and place bar on line making sure to be on center. Transfer mounting points (3 per flange) to wall. Drill pilot holes and secure bar with proper anchors per application. Snap cover over mounting plate.

**Standard Lengths (Other sizes available upon request):** 12", 16", 18", 24", 30", 32", 36", 42", 48", 50", 52", 54", 56"

## FLANGE INFORMATION

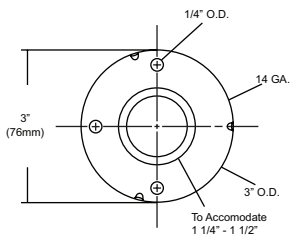
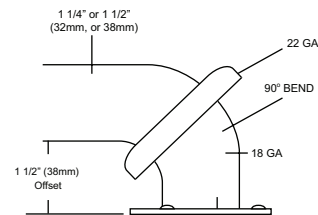

## NOTES



**UX122-BF**  
Soap Dish

Revision 10/11

JOB #:

ITEM #:

QUANTITY:

MOUNTING	HANDING	TYPE	SIZE	OTHER

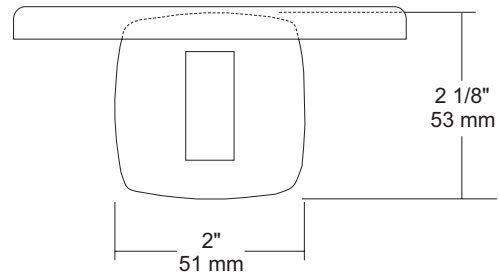
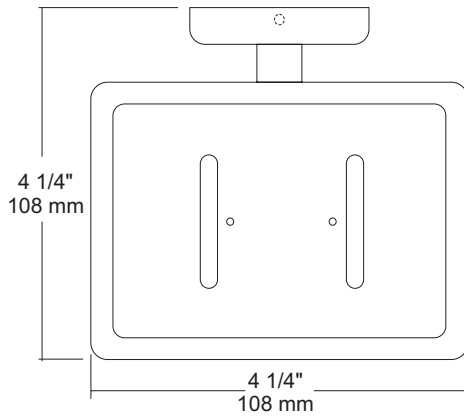

**SPECIFICATIONS**

**UX Accessories:** All UX bath accessories series are fabricated of stainless steel with a bright or satin finish. Mounting plates are concealed with a snap-on type plate secured by a set screw.

**Flange:** 2" x 2" flange #22 ga stainless steel.

**Post:** #22 ga stainless steel.

**Mounting Plate:** #16 ga concealed wall plate. Set screw secures mounting plate and flange.

**Soap Dish:** #22 ga stainless steel with drain holes

**Overall Size:** 4 1/4"W x 2 1/8"H x 4 1/4"D

**108mm x 54mm x 108mm**

**UX122-SF:** Same as UX122-BF with satin finish.

**INSTALLATION**

Provide an area on wall surface at desired or specified location. Place concealed mounting plate on wall surface and transfer mounting points. Drill pilot holes and secure with proper fasteners. Place snap on flange over plate and secure with set screw.

**NOTES**

## UX132-BF Series Round Towel Bar

Revision 03/11

JOB #:

ITEM #:

QUANTITY:

MOUNTING	HANDING	TYPE	SIZE	OTHER

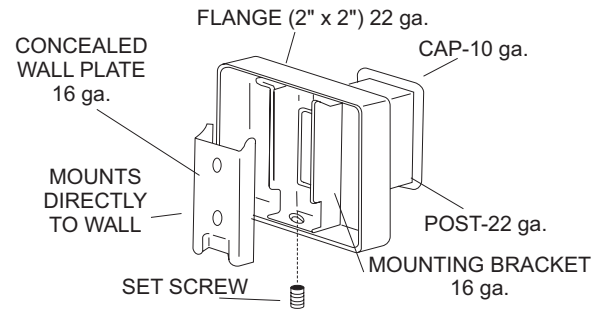
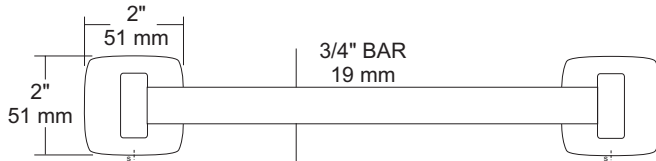
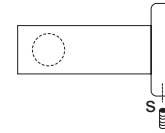
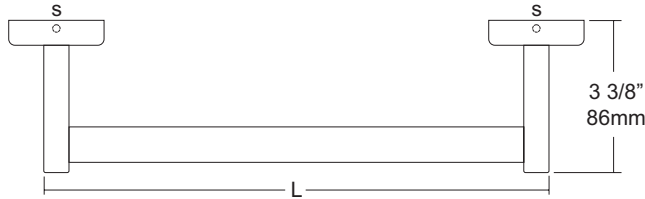

### SPECIFICATIONS

**UX Accessories:** All UX bath accessories series are fabricated of stainless steel with a bright or satin finish. Mounting plates are concealed with a snap-on type plate secured by a set screw.

**Flange:** 2" x 2" flange #22 ga stainless steel.

**Post:** #22 ga stainless steel.

**Bar:** #22 ga stainless steel, 3/4" dia

**Mounting Plate:** #16 ga concealed wall plate. Set screw secures mounting plate and flange.

**Overall Size:** 2"H x 3 3/8"D (51mm x 86mm)

**Standard Lengths:** 18", 24", 30", 36" (475mm, 610mm, 762mm, 914mm)

**UX132-SF:** Same as UX132-BF with satin finish.

### INSTALLATION

Provide an area on wall surface at desired or specified location. The centerline distance between the mounting plates is 1/2" less than the length of the towel bar. Place concealed mounting plate on wall surface and transfer mounting plate on wall surface and transfer mounting points. Drill pilot holes and secure with proper fasteners. Place snap-on flange over plate and secure with set screw. Repeat same step for second post. Place towel bar in post and place cover over plate to make sure spread is correct. Secure cover if bar fits.

### NOTES

JOB #:

ITEM #:

QUANTITY:

MOUNTING	HANDING	TYPE	SIZE	OTHER

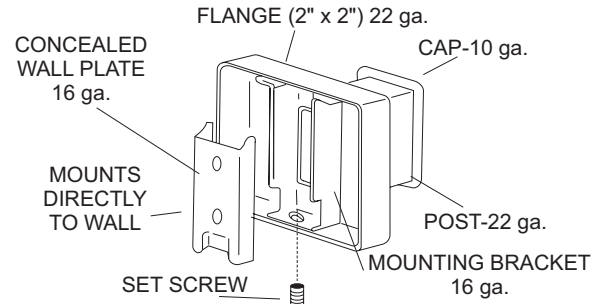
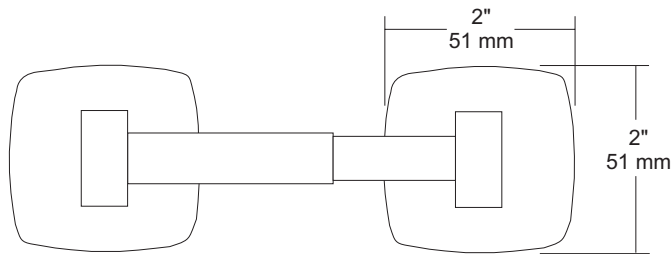
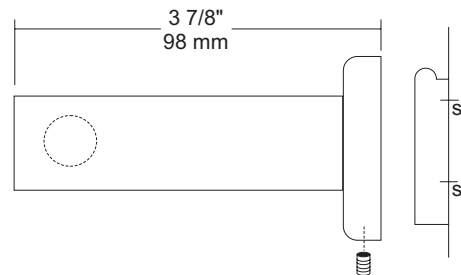
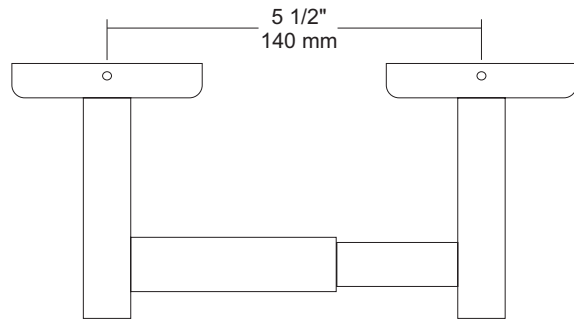

### SPECIFICATIONS

**UX Accessories:** All UX bath accessories series are fabricated of stainless steel with a bright or satin finish. Mounting plates are concealed with a snap-on type plate secured by a set screw.

**Flange:** 2" x 2" flange #22 ga stainless steel.

**Post:** #22 ga stainless steel.

**Mounting Plate:** #16 ga concealed wall plate. Set screw secures mounting plate and flange.

**Spindle:** Spring loaded, chrome plated plastic.

**Optional U007 Theft Resistant Adapter:** Prevents spindle from being removed until roll has been depleted.

**Overall Size:** 7 1/2" W x 2"H x 1 5/8"D

**51mm x 51mm x 43mm**

**UX141-SF:** Same as UX141-BF with satin finish

### INSTALLATION

Provide an area on wall surface at desired or specified location. Place concealed mounting plate on wall surface and transfer mounting points. Drill pilot holes and secure with proper fasteners. Place snap-on flange over plate and secure with set screw. Centerline space between posts is aprx. 5 1/2"W. Repeat same steps for other post. Place a roll of tissue on spindle and place in posts before securing the covers down securely. If roll spins freely, secure post with set screw. All toilet tissue dispensers must have a non-control delivery to meet ADA code. (4.16)

### NOTES



## UX1A

Flange & Shower Rod

Revision 03/11

JOB #:

ITEM #:

QUANTITY:

MOUNTING	HANDING	TYPE	SIZE	OTHER

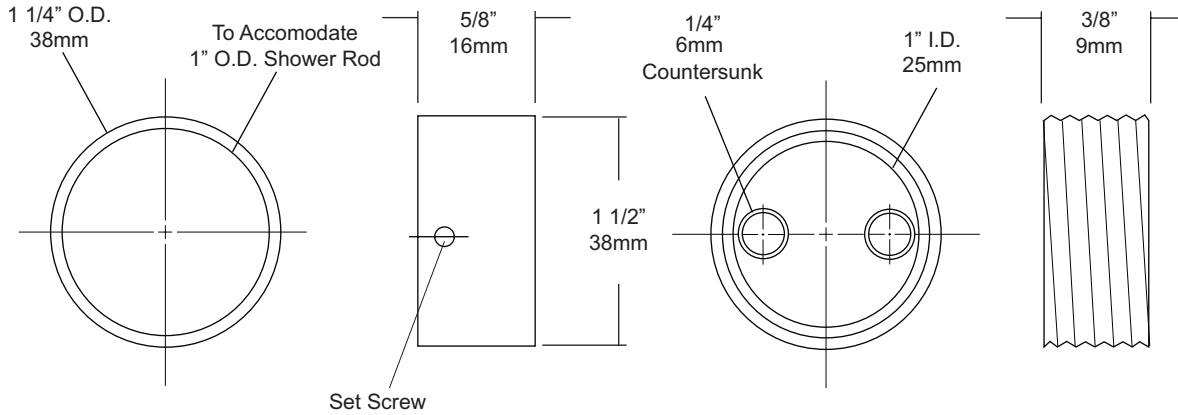

### SPECIFICATIONS

**Cover:** Fabricated of chrome on brass, with concealed mounting. One flange of the pair is equipped with a set screw to prevent rod from rotating.  
**Shower Rod:** Fabricated of 18 gauge stainless steel with a #4 satin finish.  
**UX1:** 1" outside diameter

### INSTALLATION

Provide an area on wall surface at desired or specified location. Hold flange to wall surface and transfer mounting points. Drill pilot holes. Place flanges on the ends of the rods. Secure flanges to wall surface with proper fasteners per application.

### NOTES

JOB #:

ITEM #:

QUANTITY:

MOUNTING	HANDING	TYPE	SIZE	OTHER

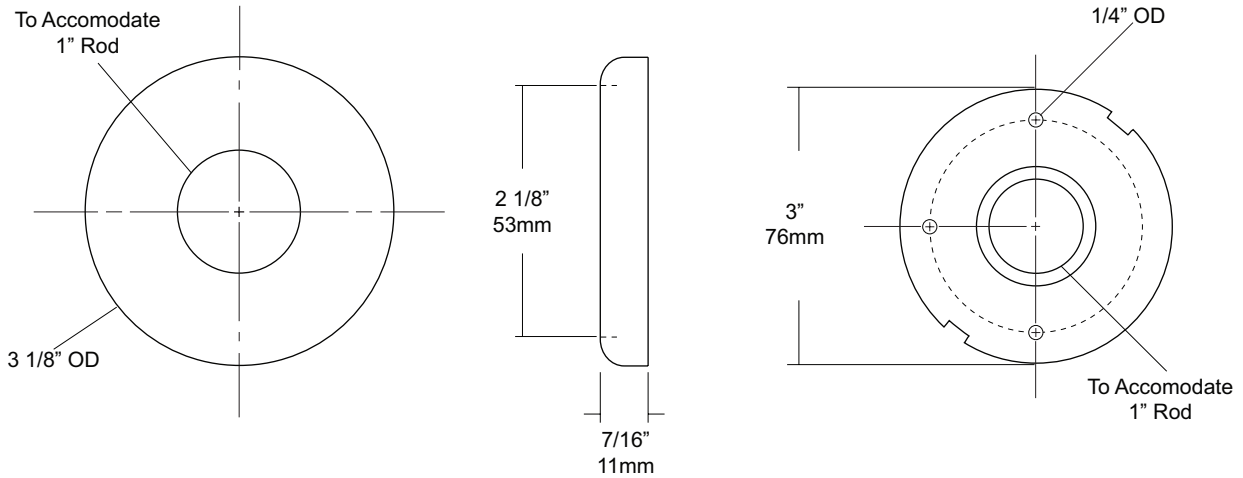

**SPECIFICATIONS**

**Concealed Mounting Plate:** #14 gauge stainless steel with three (3) mounting points to secure to mounting surface and three (3) dimples that secure snap cover escutcheon.

**Snap Cover:** Fabricated of #22 gauge stainless steel with a #4 satin finish. Cover snaps over mounting plate to provide a concealed mounting application.

**Shower Rod:** Fabricated of 18 gauge stainless steel with a #4 satin finish.

**UX1:** 1" outside diameter

**INSTALLATION**

Provide an area on wall surface at desired or specified location. Hold flange to wall surface and transfer mounting points. Drill pilot holes. Place flanges on the ends of the rods. Secure flanges to wall surface with proper fasteners per application.

**NOTES**