

date  
projectname  
attn  
from  
fax  
email  
phone

10/30/20  
John Knox Village  
Scott

## Care, Cleaning, and Maintenance Instructions – Washroom Accessories

With proper care and cleaning, as well as routine maintenance, you will help to maximize the life of your AJW accessories. Please refer to these procedures when maintaining our products:

### Stainless Steel Surfaces:

Wipe stainless steel cabinets with a soft cloth, rubbing with the grain to prevent scratching the surface. The grain of AJW's stainless steel cabinets runs in a vertical direction. Do not use abrasive cleaners containing chloric solutions on stainless steel. Avoid cleaning products that contain hydrochloric acids, bleach, or chlorides.

### Soap Dispensers:

The majority of operational issues with soap dispensers are due to improper maintenance and lack of cleaning. Soap tanks, valves, and globes should be cleaned periodically to avoid sludge and soap build up, thus promoting better operation. When soap dispensers are left unmaintained for long periods of time, the soap could potentially dry out inside the valve mechanism, causing clogs or leaking. While cleaning, do not remove or take valves apart as this creates problems with the seals and may cause a bypass leak. Flush valves with warm water. If the water does not flow through the valve after cleaning, repeat the procedure until it does.

Take care to make sure you are using the right soap in your soap dispensers. The proper viscosity is imperative for trouble free operation. AJW recommends that the soap viscosity should be at least 95 cps, and no more than 2500 cps for use in all AJW soap dispensers. Coconut oil soaps should be the only products used in liquid valve soap dispensers. We recommend that you use a standard liquid, non-chloric soap, which should be mixed in a solution of one part water to one part soap. We recommend free-flowing, thin viscosity soaps only.

### JetAir Hand Dryers:

Begin the cleaning procedure by disconnecting the electrical supply. Using the allen key supplied, remove all tamper-resistant screws and lift the cover of the dryer off of the base, and clear dust and lint from the inside of the machine and cover. When you have finished cleaning, reinstall the cover onto the base and secure with tamper-resistant screws. Wipe cover with a damp cloth; do not use abrasive cleaners. Clean the inner cover and internal mechanism periodically to ensure proper operation.

Note: Hand Dryer maintenance that is performed inside the cover should not be done by unqualified personnel.

## **Mirrors:**

Wipe mirror frames with a soft cloth, making sure to rub stainless steel frames with the grain to avoid scratching. Do not use abrasive cleaners containing chloric solutions on stainless steel frames.

Mirror glass should be cleaned by spraying cleaner on a soft cloth, and then wiped onto the mirror (it is best if cleaner is not sprayed directly onto the mirror). This will ensure that cleaning agents do not run down the mirror and into the frame. If a cleaning agent and/or still water is allowed to sit in a frame or on the back of a mirror, it will lead to a de-lamination of the protective coating, and/or the mirror silver, voiding the AJW warranty.

Note: Soap dispensers should not be mounted directly on a mirror surface, as soap residue and water from a person's hand can be splashed into the mirror frame, causing the same de-lamination as described above.

## **Corrosive Chemical / Surface Rust Alert**

Stainless steel is very resistant to rust, however it is not entirely impervious to it. Proper care, especially under corrosive conditions is needed. Cleaning your stainless steel surface using the instructions above is necessary, but it is also important to keep your stainless steel surface free from contaminants.

The below listed substances will react with stainless steel to produce rust and corrosion. These elements are commonly used in caustic cleaning agents, and should never be used to clean stainless steel washroom accessories. The most common elements that react adversely with stainless steel include:

Bromide  
Chloride  
Fluoride  
Iodine

Other common acids and compounds cause significant damage to stainless steel. Stainless steel will sustain permanent discoloration and/or corrosion if the material comes into contact with even vapor fumes from these substances. The following acids and compounds should never be used to clean any stainless steel product:

Acetic Acids  
Nitric Acids  
Phosphoric Acids  
Hydrochloric / Muriatic Acids  
Sodium Chlorides (contains salt)  
Sodium Hydrochloride (Bleach)  
Sodium Hydroxide  
Sulfuric Acids



Some other conditions that can cause stainless steel to corrode, discolor, or develop surface rust are:

1. Contact with Muriatic Acid (commonly used to clean up after tile or concrete installation).
2. Soap residue (chemical additives will cause discoloration and dried soap residue actually looks like rust).
3. Water with high iron content can leave a rusty residue, especially after continuous contact.

### **Surface Rust Removal**

If your stainless steel surface is exposed to any of the contaminants above, please follow the instructions below to remove any discoloration:

- Wash affected accessory with a mild dish detergent and warm water.
- Dry all surfaces with a towel or soft cloth.
- Using a dry Scotch Brite pad, rub all surfaces until rust marks are completely removed. Be sure to rub in the direction of the grain to prevent scratching. Grab bars may be cleaned using a rotating motion, as the grain is random in these products. Do not use on bright polish stainless steel.
- Rinse with a damp cloth and dry with a soft cloth.



# U125 Soap Dispenser

Revision 11/14

JOB #:

ITEM #:

QUANTITY:

MOUNTING	HANDING	TYPE	SIZE	OTHER

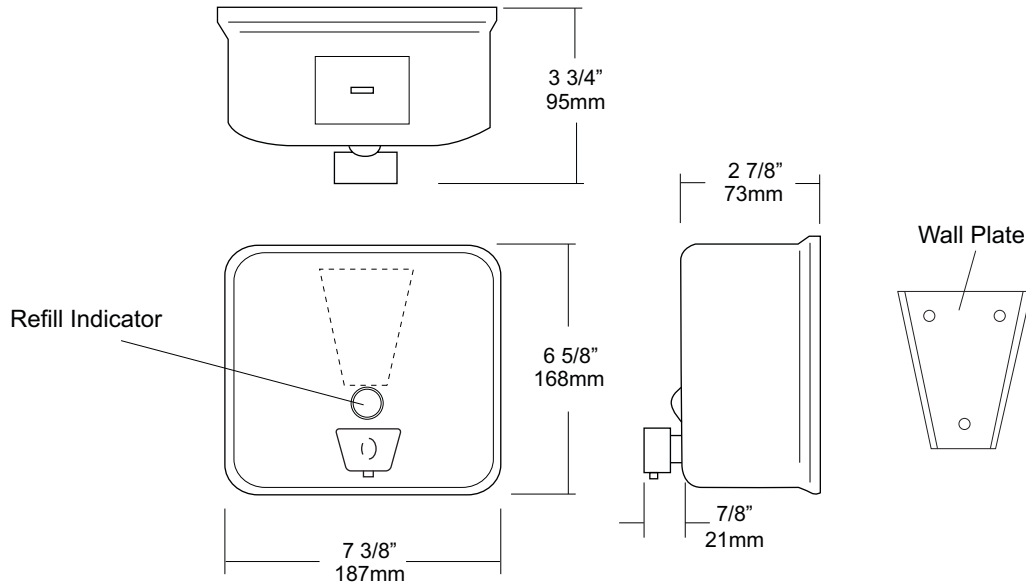

## SPECIFICATIONS

**Tank:** #20 ga stainless steel with satin finish, Drawn one piece construction with a curved front design and radius corners.

**Back:** #22 gauge stainless steel with #20 gauge stainless steel mounting plate attached. Back plate and tank are welded together to form a one piece unit

**Valve:** All purpose antibacterial soap valve cylinder, black molded plastic push style valve that takes less than 5 lbs of force and one hand to operate complies with barrier free guidelines when mounted at proper height.

**Refill Indicator:** Clear plastic viewer window allows a constant fluid level check.

**Filler Cap:** Fabricated of stainless steel, hinged to allow easy servicing, Cap is secured with special key that creates a vandal resistant dispenser.

**Overall Size:** 7 3/8"W x 6 5/8"H x 3 3/4"D

**187mm x 168mm x 95mm**

**Capacity:** 45 oz

**Recommend type soaps without chloric solutions for proper operation.**

## INSTALLATION

Provide an area on wall surface at desired or specified location, Secure concealed mounting plate to wall surface with proper fasteners, Slide dispenser down over mounting plate and secure by means of a set screw located inside the tank accessible by opening service lid, Fill unit with soap, Secure lid, Prime the valve and test for proper operation.

\*It is not recommended to mount any soap dispenser on mirrors

\*\*For best performance, use pre-mixed low concentrate solutions. Dispensers should have periodic maintenance performed to insure the life dispenser. Rinse out globe and valve with warm water to avoid sludge buildup.

Preventative Maintenance: Each dispenser should be flushed out aprx, Every 30 days with warm water to prevent valve from; clogging with old soap, Abrasive cleaners should not be used when wiping down dispenser.

## NOTES



# U135EA

## Hands Free Soap Dispenser

Revision 05/14

JOB #:

ITEM #:

QUANTITY:

MOUNTING	HANDING	TYPE	SIZE	OTHER

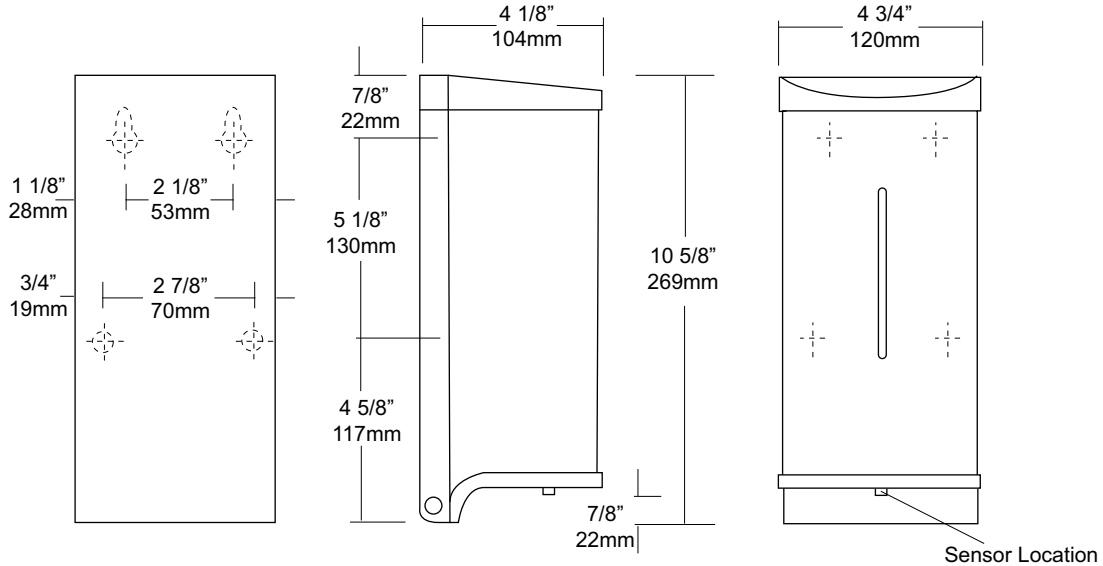

### SPECIFICATIONS

**Cover:** Fabricated of stainless steel with #4 satin finish with a refill indicator on face of unit to provide a constant fluid level check.

**Cap & Base:** high impact black plastic with radius leading edges.

**Sensor:** Hands free application allows 1 - 1.5 Cc's (one drop) per dispensing cycle. LED flashes three (3) times means stand by for dispensing. When the LED flashes blue this indicates battery is low. Requires 4 AA batteries (not included). Alkaline type batteries recommended to provide maximum operation without changing batteries.

**Soap Container:** High capacity 800ml translucent plastic tank with flexible valve stem. Globe is equipped with large filler cap for easy servicing.

**Lock:** Vandal resistant security lock and key.

**Overall Size:** 4 3/4"W x 10 5/8"H x 4 1/8"D  
**121mm x 271mm x 105mm**

### INSTALLATION

If mounting on wall surface, transfer mounting hole dimensions from back of unit to wall surface. Drill pilot holes and secure unit to surface with proper fasteners. Sensor cannot be any higher than 40" above finished floor to comply with ADA code.

\*It is not recommended to mount any soap dispenser on mirrors

\*\*For best performance, use pre-mixed low concentrate solutions. Dispensers should have periodic maintenance performed to insure the life of the dispenser. Rinse out bottle and valve with warm water to prevent sludge buildup.

Preventative Maintenance: Each dispenser should be flushed out aprx. Every 30 days with warm water to prevent valve from clogging with old soap. Do not use abrasive cleaners to clean dispenser.

### NOTES



# U169EA-SR

Roll Towel Dispenser

Revision 05/12

JOB #:

ITEM #:

QUANTITY:

MOUNTING	HANDING	TYPE	SIZE	OTHER

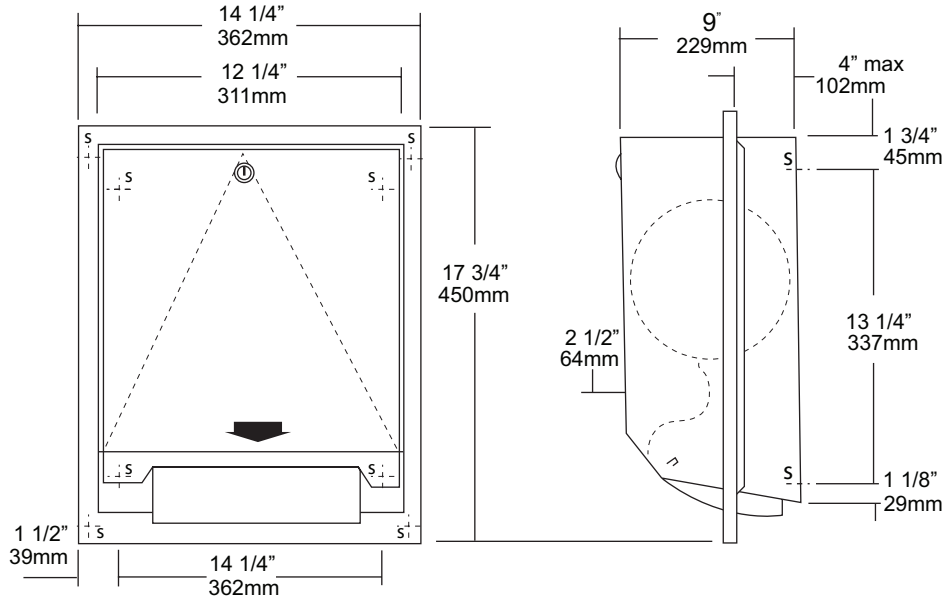

## SPECIFICATIONS

**Cabinet Body:** Fabricated of #22 ga stainless steel with #4 satin finish.

**Cabinet Door:** Fabricated of #18 ga stainless steel, #4 satin finish.

**Back:** #22 ga stainless steel, with key hole slots for mounting.

**Roll Towel Mechanism:** Internal mechanism is fabricated of high impact plastic operated by an automatic sensor.

**Sensor:** Operated by four (4) D cell batteries (not included). After batteries and paper have been properly installed, pass hands through sensor range to activate motor. After unit has 30 seconds to calibrate, it is ready to dispense. It takes aprx. 6 dispenses to adjust to the proper paper length. After the sensor range has been interrupted, paper will not be dispensed until sensor range has been cleared to reset.

**Semi-Recessing Flange:** #22 gauge stainless steel with 1/4" returns for maximum rigidity. One piece construction without miters or welds along with a #4 satin finish will match rest of cabinet. Adjustable flange recessing depth is 3 1/4" - 5".

**Overall Size:** 14 1/4"W x 17 3/4"H x 9"D  
**362mm x 450mm x 267mm**

**Wall Opening:** 12 1/2"W x 16 1/2"H x 3 1/4"D-5"D  
**318mm x 457mm x 95mm**

**Capacity:** One standard size roll of 8" or 9" wide. (Use only non-perforated towels). One stub roll up to 2 3/4" OD

**\*Recommended 600ft roll for best results.**

## INSTALLATION

Provide an area on mounting surface at desired or specified location. Coordinate installation with architect / contractor. Open cabinet door, place unit against wall making sure unit is level and transfer mounting points. Top of cabinet should be no higher than 48" above finished floor to comply with ADA Code. Secure cabinet to wall surface with proper fasteners for each application. Load towels in cabinet per instruction label.

## NOTES

Formerly Model #: U169A/199EA-SR



# U180

Folded Towel Dispenser

Revision 03/11

JOB #:

ITEM #:

QUANTITY:

MOUNTING	HANDING	TYPE	SIZE	OTHER

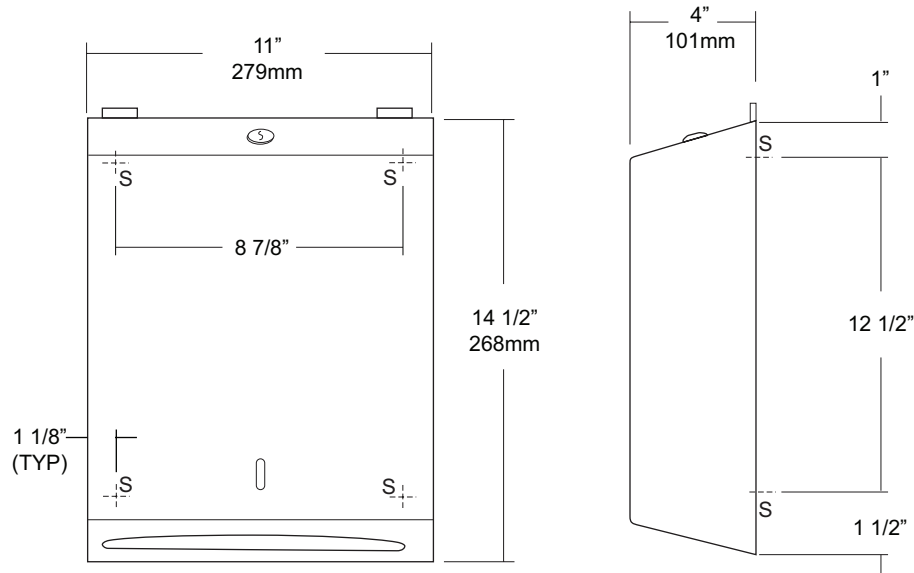

### SPECIFICATIONS

**Cabinet:** #22 ga. stainless steel with #4 satin finish. Striker tabs prevents damage to mounting surface when cover is closed. (Unibody design)

**Cabinet Back:** #22 ga stainless steel with embossed towel guides.

**Hinges:** Full length, heavy duty, stainless steel , piano type hinge. (Welded, no rivets)

**Locks:** Pin tumbler, commercial quality, keyed like all other AJW cabinets.

**Towel Dispenser:** Area is hemmed to prevent towel tearing and injury.

**Overall Size:** 11"W x 14 1/2"H x 4"D (stainless steel)  
**279mm x 368mm x 102mm**

**Capacity:** 400 c-fold or 525 multifold

**Options:**

- TK: Twist lock in lieu of keyed lock.

### INSTALLATION

Provide an area on mounting surface at desired or specified location. Open cover and place unit against wall and transfer mounting points after checks out to be level and is at the proper mounting height. Secure unit to surface with proper fasteners, fill cabinet with towels, close cover and remove key.

Recommend towel dispensing area at a height of 40" above finished floor to meet ADA Code.

### NOTES





**U480**  
Countertop Waste Chute

Revision 03/11

JOB #:

ITEM #:

QUANTITY:

MOUNTING	HANDING	TYPE	SIZE	OTHER

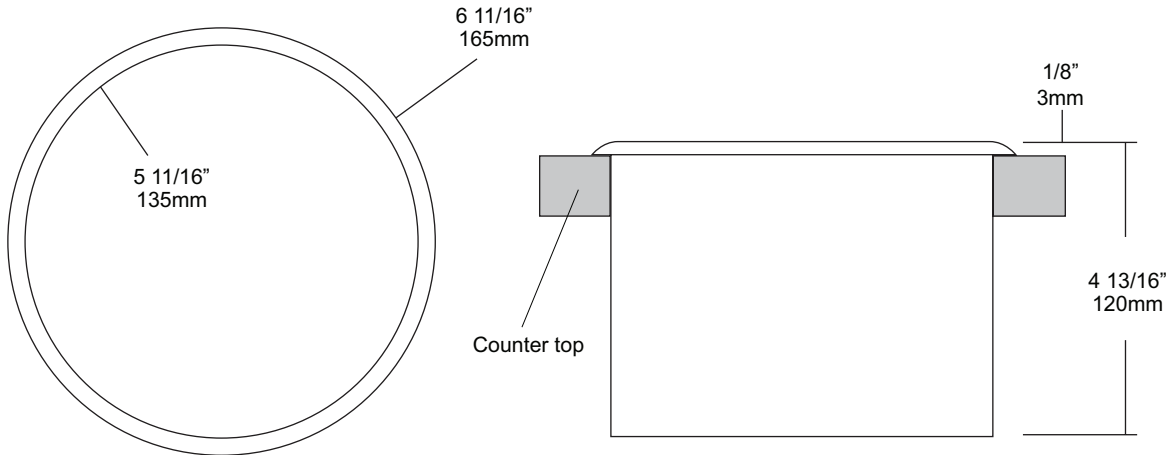

**SPECIFICATIONS**

**Waste Chute:** Fabricated of #22 ga stainless steel with a bright polished finish on all exposed surfaces seamless one piece construction.

**Overall Size:** 6 11/16" OD x 4 13/16"D

**169mm x 122mm**

**Counter top Opening:** 5 13/16" diameter

**INSTALLATION**

Provide an area on counter top at desired or specified location. Coordinate installation with architect contractor to avoid interference with pipes. Cut 5 13/16" diameter opening for chute using proper tools. Fill in the underside of flange and around the area of the cut out counter top with silicone (not provided) and insert into opening. Clean off any excess sealant above and below counter. Waste receptacle is not provided and must be purchased separately.

**NOTES**

JOB #:

ITEM #:

QUANTITY:

MOUNTING	HANDING	TYPE	SIZE	OTHER

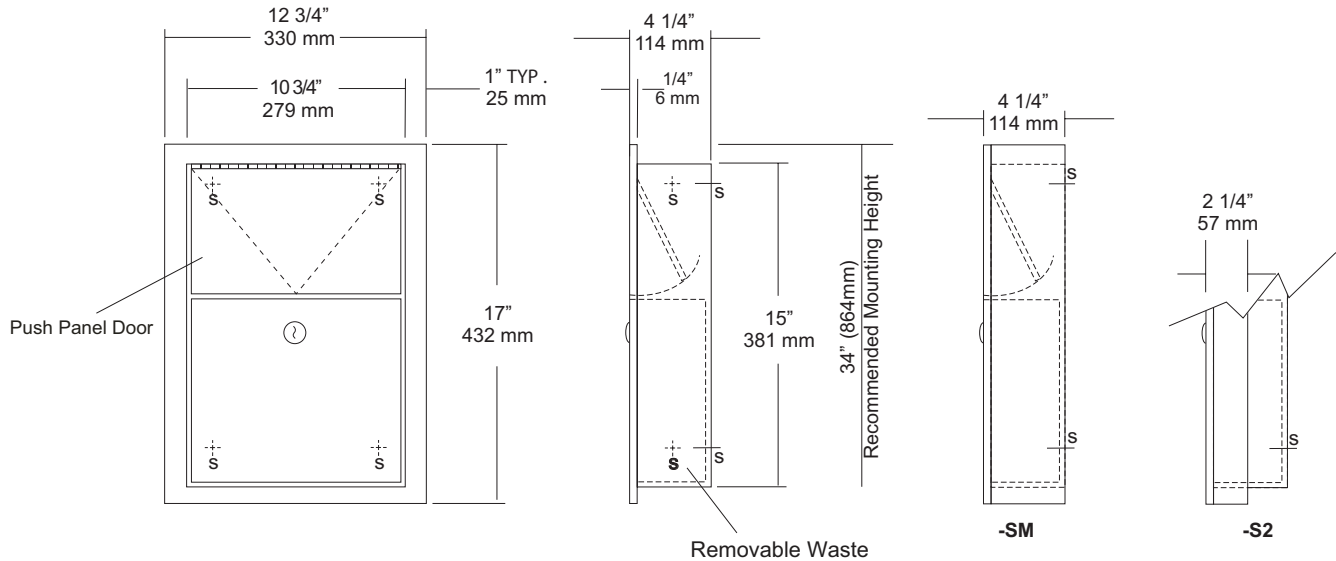

### SPECIFICATIONS

**Body:** Fabricated of #22 ga stainless steel, #4 satin finish.  
**Flange:** Fabricated of #22 ga stainless steel #4 satin finish, drawn one piece construction with 1/4" returns to wall surface. (Without miters or welds)  
**Push Panel:** #22 ga stainless steel self closing push panel door.  
 \*International Graphic Symbols are optional.  
**Waste:** #22 ga stainless steel, removable type waste, secured by pin tumbler lock. Pin tumbler commercial quality locks, keyed like all other AJW cabinets. \*(Optional finger grip in lieu of lock)  
**Hinges:** Full length, heavy duty, stainless steel hinge.  
**Collars:** #22 ga stainless steel finished and sized to match cabinet.  
**Overall Size:** 12 3/4"W x 17"H x 4 1/4"D  
**330mm x 432mm x 108mm**  
**Wall Opening:** 11 1/4"W x 15 1/2"H x 4"D  
**292mm x 394mm x 108mm**  
**Capacity:** 1.5 gallons (.2 cu ft)  
**U581-S2:** semi-recessed Disposal  
**Wall Opening:** 11 1/4"W x 15 1/2"H x 2"D  
**292mm x 394mm x 51mm**  
**NDL-13-50:** Waxed disposable liners(50 per Case)  
**C12174 :** Collar will convert recessed to surf mounted.  
**U581-PW:** Same as U581 with plastic removable waste.

### INSTALLATION

Coordinate installation with architect or contractor to avoid interference with pipes, vents, etc. Provide a rough wall opening 11 1/2"W x 15 1/2"H. Verify depth for either the recessed or semi-recessed model. Remove waste from cabinet and secure in opening with proper fasteners for each application making sure unit is level.

### NOTES



# U650

## Folded Towel & Waste Combination Unit

Revision 10/14

JOB #:
ITEM #:
QUANTITY:

MOUNTING	HANDING	TYPE	SIZE	OTHER

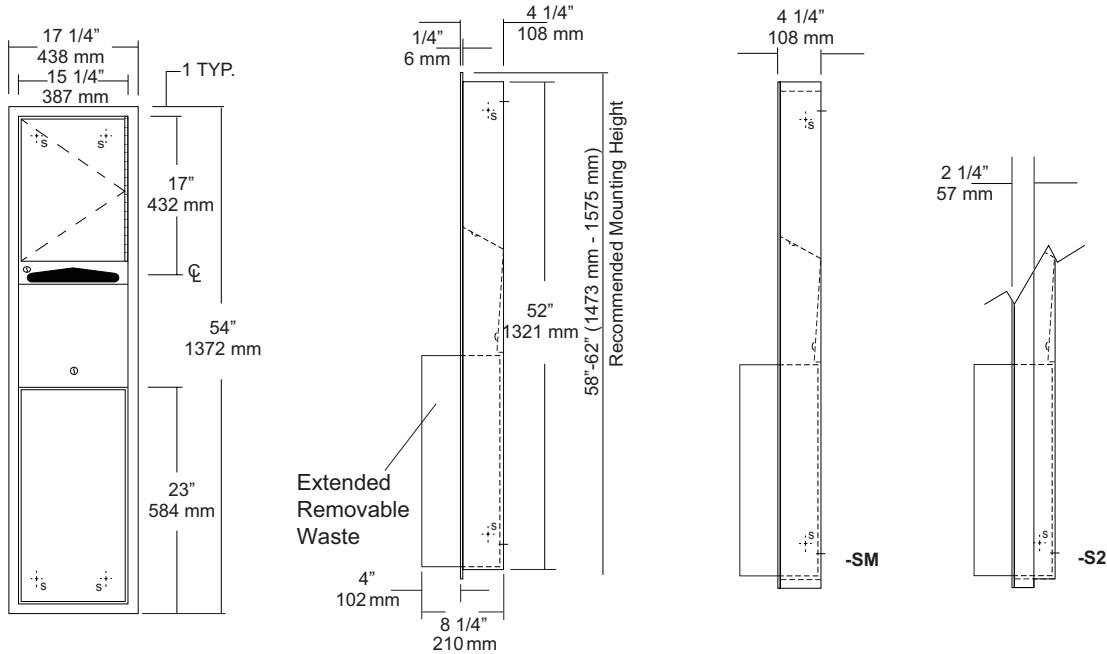

### SPECIFICATIONS

**Body:** Fabricated of #22 ga stainless steel with a #4 satin finish.

**Flange:** Fabricated of #22 ga stainless steel finished to match cabinet with 1/4" returns. (No miters or welds)

**Cabinet Back:** Fabricated of stainless steel formed for rigidity with multiple welds to cabinet body.

**Cabinet Door:** Fabricated of #22 ga stainless steel with #4 satin finish.

**Towel Dispenser:** Fabricated of #22 ga stainless steel with hemmed edges to prevent injury and towel tearing.

**Removable Waste:** Fabricated of #22 ga stainless steel #4 satin finish with all leading edges to have a radius. Unit is secured in place by a bottom bracket guide and top lock.

**Hinge:** Full length, heavy duty, stainless steel piano type hinge.

**Locks:** Pin tumbler commercial quality, keyed like all other AJW cabinets.

**Collars:** Fabricated of #22 ga stainless steel, finished to match cabinet. (Used when full recessing cannot be accomplished)

**Overall Size:** 17 1/4"W x 54"H x 8 1/4"D  
**438mm x 1372mm x 210mm**

**Wall Opening:** 15 3/4"W x 52 1/2"H x 4"D  
**400mm x 1334mm x 102mm**

**U650-S2:** semi-recessed. with 2" collar, 2" wall opening 51mm

**U650-SM:** Full surface mounted collar.

**Towel Capacity:** 600 c-fold or 800 multifold

**Waste Capacity:** 12 gallons (1.6 cu ft)

**Options :**

**-VL1:** Vinyl Liner

### INSTALLATION

Coordinate installation with architect and contractor to avoid interference with pipes, vents, etc. Provide a rough wall opening 15 3/4"W x 52 1/2"H. See chart for required wall depth. If collar is required, slide collar over the back before installing into wall. Remove waste from cabinet and mount unit plumb and true in opening with proper fasteners per application. Secure waste in cabinet and load paper towels.

When cleaning cabinet use a non abrasive non-chloric solution and wiped off with the grain of the cabinet.

### NOTES



**U815**  
Toilet Tissue Dispenser & Shelf  
Combination Unit

Revision 03/11

JOB #:

ITEM #:

QUANTITY:

MOUNTING	HANDING	TYPE	SIZE	OTHER

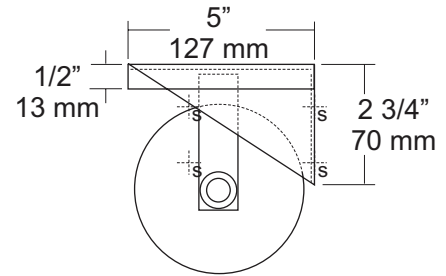
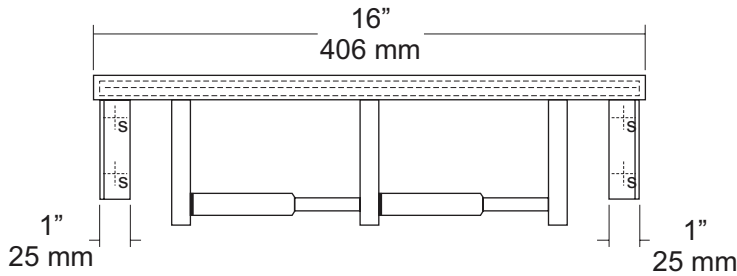

**SPECIFICATIONS**

**Shelf:** Fabricated of #18 gauge stainless steel with a #4 satin finish. Sides of shelf are bent down 1/2" with front edge bent down 1/2" along with 1/2" returns back for added rigidity and safety.

**Brackets:** Fabricated of #18 gauge stainless steel formed for maximum strength.

**Toilet Tissue Dispenser:** Fabricated of stainless steel with a #4 satin finish. (UX142-SF)

**Rollers:** High impact, chrome plated ABS that is spring loaded.

**U007 Theft Resistant Adapter:** Prevents spindle from being removed until roll has been depleted.

**Overall Size:** 16"W x 4"H x 5"D

**406mm x 102mm x 127mm**

**Capacity:** One standard rolls with a 5 1/4" (133mm) OD.

**INSTALLATION**

Place unit against mounting surface. Making sure unit is level, transfer mounting point locations and drill pilot holes. Secure with proper fasteners per each application. Install toilet tissue rolls.

Toilet Paper Dispensers: All dispensers that are to meet ADA code cannot have any type of controlled delivery. (4.16)

**NOTES**

Formerly Model #: U815-42

JOB #:

ITEM #:

QUANTITY:

MOUNTING	HANDING	TYPE	SIZE	OTHER

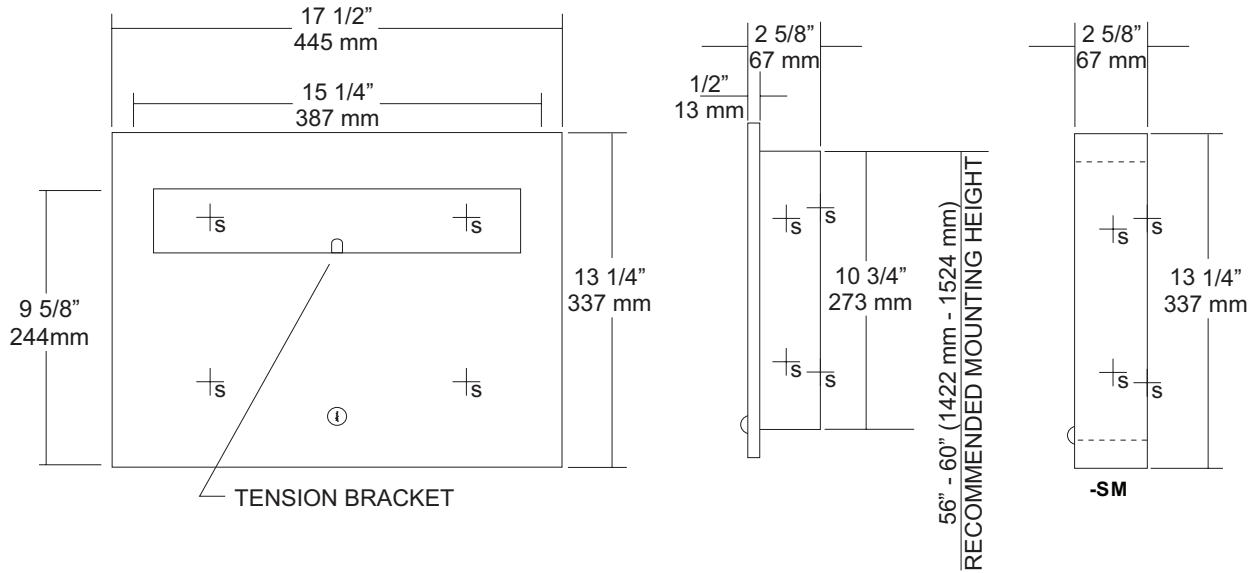

### SPECIFICATIONS

**Body:** Fabricated of #22 gauge stainless steel with a #4 satin finish on all exposed surfaces.

**Flange:** #22 gauge stainless steel with 1/4" returns to wall without any miters.

**Uni-Door:** #18 ga stainless steel door. Seat cover dispensing area (on both units) are deburred and polished smooth to avoid paper tearing and injury.

**Hinge:** Full length, stainless steel piano type hinge.

**Lock:** Pin tumbler commercial quality, keyed like all other AJW cabinets.

**Overall Size:** 17 1/2"W x 13 1/4"H x 2 5/8"D

**445mm x 337mm x 68mm**

**Wall Opening:** 15 3/4"W x 11 1/4"H x 2 5/8"D

**400mm x 286mm x 60mm**

**U8504-SM:** Surface mounted unit

**Capacity:** 500 seat covers

### INSTALLATION

Provide required wall opening at desired or specified location with coordination with architect or contractor to avoid interference with pipes, vents, etc. Unlock cabinet and place unit in opening. Secure to rough framing with proper fasteners per each application. Fill dispenser with product and secure cabinet door.

### NOTES



# U939

## Retractable Shower Bench

Revision 12/14

JOB #:

ITEM #:

QUANTITY:

MOUNTING	HANDING	TYPE	SIZE	OTHER

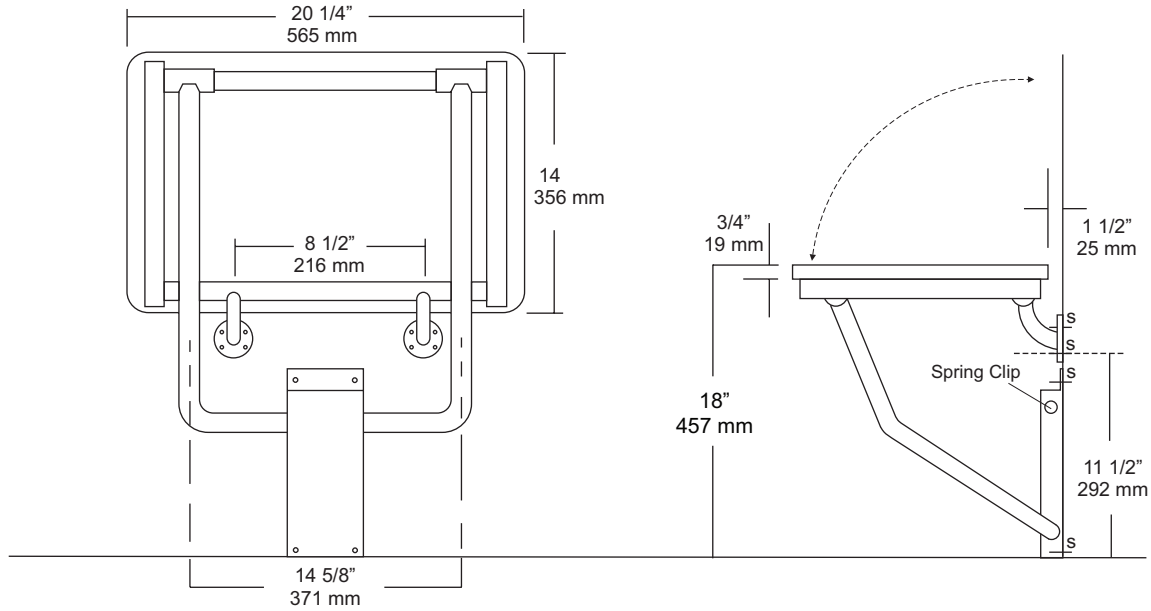

### SPECIFICATIONS

**Seat:** Fabricated of 3/4" thick, one piece polymers (white) with all leading edges having a radius to prevent injury. Seat is secured to frame with carriage bolts and acorn nuts.

**Tubing:** Fabricated of #18 ga stainless steel with #4 satin finish.

**Main Frame:** 1 1/4" diameter square tubing with capped ends.

**Flanges:** #18 gauge stainless steel with four (4) countersunk exposed mounting points. Under slung supports have a 1 1/4" OD. (Satin finish)

**Mounting Bracket:** #14 ga stainless steel "hat" style bracket with 4 mounting support points. Bracket acts as a guide to raise and lower seat platform and is equipped with four (4) points to secure to wall surface. For maximum support, bracket is mounted so the bottom is set on the finished floor surface. Seat will remain in an upright position when not in use by means of a spring clip.

**Overall Size:** 20 1/4"W x 14"D (seating area)

**514mm x 356mm**

**\*Wall to floor mounting design provides equal distribution of weight to ensure safe operation.**

### INSTALLATION

To comply with ADA Code, seat should be mounted at a height 17"-19" above finished floor. Check all state and local codes for building requirements. Recommend in wall mounting on all shower seats. (BP10) Place seat up against wall making sure the extended part of seat has an offset no more than 1 1/2" away from wall. (Same as grab bar) Transfer mounting points to wall surface and drill pilot holes. Secure seat to surface with proper fasteners per each application. Snugly secure seat to surface and check seat to be level. If seat is level raise and lower seat to check path of travel. Finish securing seat after checking seat for proper operation. When properly mounted seat will support up to 250 lbs and will conform with ADA Code 4.21.3 and 4.26.3

Note: This shower seat is not intended to be installed in applications that have shower bases with rounded corners. AJW recommends the U928 for such applications.

### NOTES

Formerly Model #: U939-1A



# UG2-A

Grab Bars

Revised 03/11

JOB #:

ITEM #:

QUANTITY:

MOUNTING	HANDING	TYPE	SIZE	OTHER

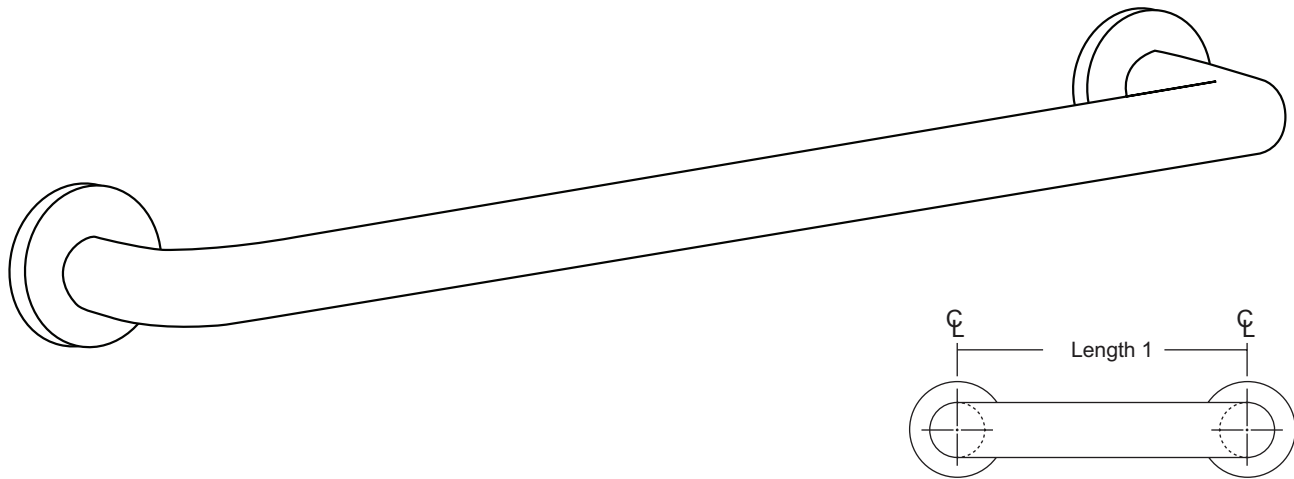

## SPECIFICATIONS & INSTALLATION

**Tubing:** Fabricated of #18 ga stainless steel with a #4 satin finish. Available in 1 1/4" outside diameter. All bends are formed by an automatic mandrel bending process. All bars maintain a constant 1 1/2" offset.

**Finish:** Standard finish is a #4 satin finish. For a non-slip finish (peened) add suffix X to model number. (Ex. UG2X-A)

**Flanges:** Snap flanges are fabricated of 3" diameter, 3/8" deep drawn #22 ga stainless steel with #4 satin finish to match tubing. Flanges have dimples that secure over mounting plate.

**Strength:** Bars with a 1 1/2" offset clearance will support loads in excess of 900lbs when properly installed. Bars with greater offsets will support loads up to 250lbs when properly installed.

**Installation:** Before installing grab bars, verify with all state and local codes for requirements on bar diameter and type finish. Recommended mounting heights for grab bars are 33" - 36" centerline above finished floor. All mounting of grab bars when possible should have in wall mounting back plates. Find centerline mounting points and place bar on line making sure to be on center. Transfer mounting points (3 per flange) to wall. Drill pilot holes and secure bar with proper anchors per application. Snap cover over mounting plate.

**Standard Lengths (Other sizes available upon request):** 12", 16", 18", 24", 30", 32", 36", 42", 48", 50", 52", 54", 56"

## FLANGE INFORMATION

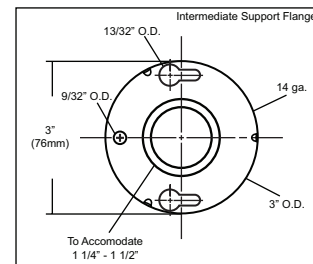
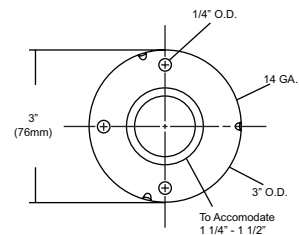
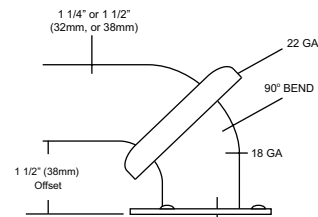

## NOTES

## UX1A

Flange & Shower Rod

Revision 03/11

JOB #:

ITEM #:

QUANTITY:

MOUNTING	HANDING	TYPE	SIZE	OTHER

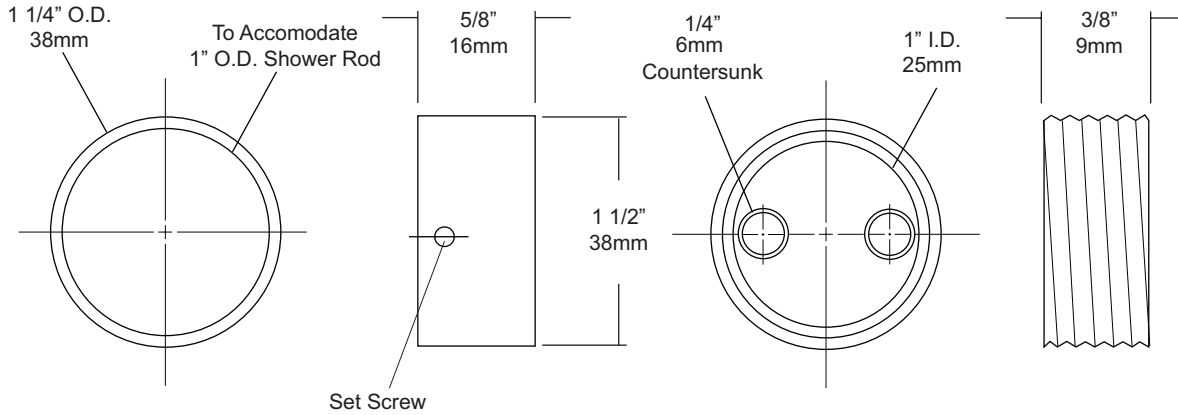

### SPECIFICATIONS

**Cover:** Fabricated of chrome on brass, with concealed mounting. One flange of the pair is equipped with a set screw to prevent rod from rotating.  
**Shower Rod:** Fabricated of 18 gauge stainless steel with a #4 satin finish.  
**UX1:** 1" outside diameter

### INSTALLATION

Provide an area on wall surface at desired or specified location. Hold flange to wall surface and transfer mounting points. Drill pilot holes. Place flanges on the ends of the rods. Secure flanges to wall surface with proper fasteners per application.

### NOTES





## Warranty – Washroom Accessories

### Accessories

AJW guarantees its Washroom Accessories to be free of material defects, and defects from workmanship for a period of one (1) year from the date of shipment.

### Baby Changing Stations

AJW baby changing stations are guaranteed for five (5) years from the date of shipment.

### Mirrors

We guarantee our mirrors against silver spoilage for a period of fifteen (15) years under normal use. This guarantee includes all ¼” plate glass mirrors including tempered, laminated, and all other ¼” safety glass mirrors.

### Hand Dryers

Our Jet Air hand dryers are warranted to be free of defects from workmanship under normal use and maintenance for a period of five (5) years from date of shipment (with the exception of the U1511EA which has a warranty period of two (2) years from date of shipment). Hand dryer warranty info is as follows:

- U1511EA- 2 Year Limited Warranty, Motor Brushes 2 Years, Eye Sensor One Year
- U1512EA- 5 Year Limited Warranty, Motor Brushes 2 Years, Eye Sensor One Year
- U1521EA- 5 Year Limited Warranty, Eye Sensor One Year
- U1525EA- 5 Year Limited Warranty, Eye Sensor One Year

**This warranty excludes defects in the Washroom Accessory caused by: vandalism, improper use, improper installation, neglect, and environmental damage.**

**If the Washroom Accessory is found to be defective in workmanship or materials within the warranty period, AJW will replace all affected components, free of charge. AJW will not be responsible for any other expenses including, but not limited to: removal costs, installation costs, freight costs, or any other costs associated with the repair or replacement of the product.**

**The replacement or repair of defective material as stated in this warranty shall constitute the sole remedy of the buyer and the sole liability of AJW under this warranty. AJW shall not be liable for any incidental, consequential, or indirect damages caused by the failure or defect in the material supplied, or any delay in the replacement or repair of warranty items.**

**Warranty claims must be made during the warranty period, and communicated to AJW by contacting AJW Architectural Products at: 509 Temple Hill Road – New Windsor, NY 12553 – Phone: 845-562-3332.**