

date
projectname
attn
from
fax
email
phone

10-21-2016
Marshall Co Jury Restroom
Jean Golowina
john Olszewski
724-693-8766
john@olszewskisales.com
724-693-2666



U144

Soap Dispenser

Revision 09/15

JOB #:

ITEM #:

QUANTITY:

MOUNTING	HANDING	TYPE	SIZE	OTHER

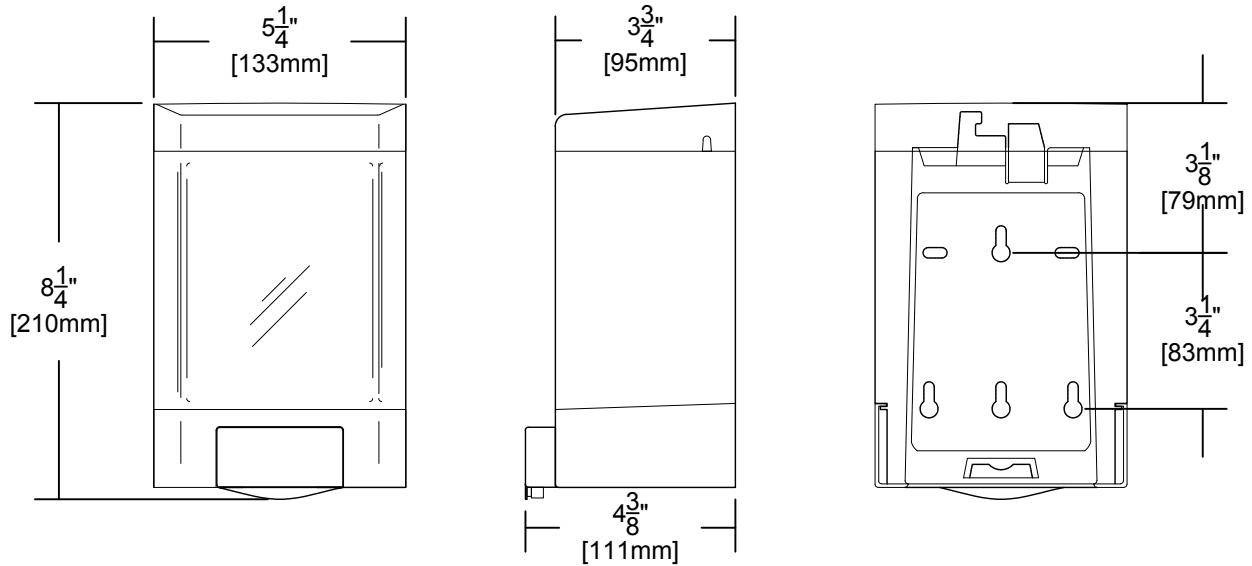

SPECIFICATIONS

Soap Tank: Fabricated of translucent high impact ABS material with a smooth curved design.

Body & Cover: Fabricated of white high impact plastic material. Hidden security locking mechanism prevents vandalism. Large convenient filler cap allows easy servicing of dispenser.

Valve: Fabricated of high impact plastic material that will dispense most liquids, lotions, and hand sanitizers (NOT pumice soaps or foam soaps). Large push button allows easy one hand operation that requires less than 5 lbs of force to operate. When properly mounted dispenser will comply with ADA code.

Overall Size: $5\frac{1}{4}$ "W x $8\frac{1}{4}$ "H x $4\frac{3}{8}$ "D (Wall to Valve)
133mm x 210mm x 111mm

Capacity: 46 fluid oz.

INSTALLATION

If mounting on wall surface, transfer mounting hole dimensions from back of unit to wall surface. Drill pilot holes and secure unit to surface with proper fasteners. Sensor cannot be any higher than 40" Above finished floor to comply with ADA code.

* It is not recommended to mount any soap dispenser on mirrors

** For best performance, use pre-mixed low concentrate solutions. Dispensers should have periodic maintenance performed to insure the life of the dispenser. Rinse out bottle and valve with warm water to prevent sludge buildup.

Preventative Maintenance: Each dispenser should be flushed out approx. Every 30 days with warm water to prevent valve from clogging with old soap. Do not use abrasive cleaners to clean dispenser.

NOTES



U582
Surface Mounted Sanitary Napkin
Disposal

Revision 03/11

JOB #:

ITEM #:

QUANTITY:

MOUNTING	HANDING	TYPE	SIZE	OTHER

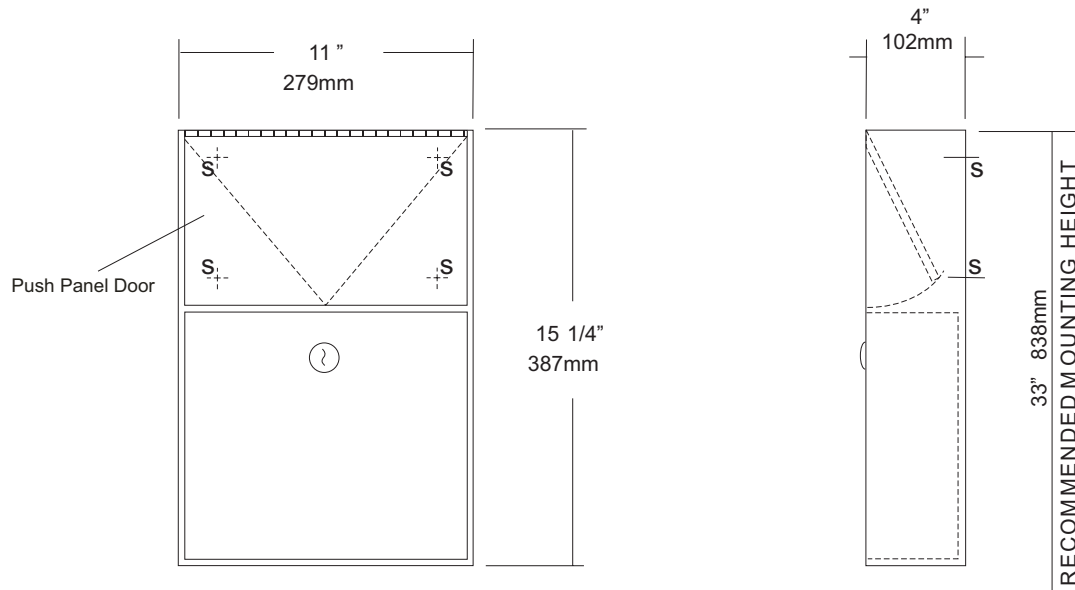

SPECIFICATIONS

Cabinet Body: Fabricated of #22 ga stainless steel #4 satin finish,
Push Panel: Fabricated of #22 ga stainless steel self closing push panel. International graphic symbols are optional.
Waste: #22 ga stainless steel removable type waste secured by a pin tumbler lock. Optional finger grip in lieu of lock is available.
Locks: Pin tumbler commercial quality locks keyed like all other AJW cabinets,
Hinge: Full length, heavy duty, stainless steel piano type hinge,
Overall Size: 11"W x 15 1/4"H x 4"D
279mm x 387mm x 102mm
Capacity: 1.5 gallons (.2 cu ft.)
NDL-13-50: Waxed disposable liners. (50 per Case)
OPTIONS:
-PW: Rigid plastic waste insert
-IGS: International Graphic Symbol

INSTALLATION

Provide an area on wall surface at desired or specified location. Place unit on wall and verify unit is level. Transfer mounting point locations and drill pilot holes. Remove waste can and secure to wall surface with proper fasteners for each application.

NOTES



U650

Folded Towel & Waste Combination Unit

Revision 10/14

JOB #:

ITEM #:

QUANTITY:

MOUNTING	HANDING	TYPE	SIZE	OTHER

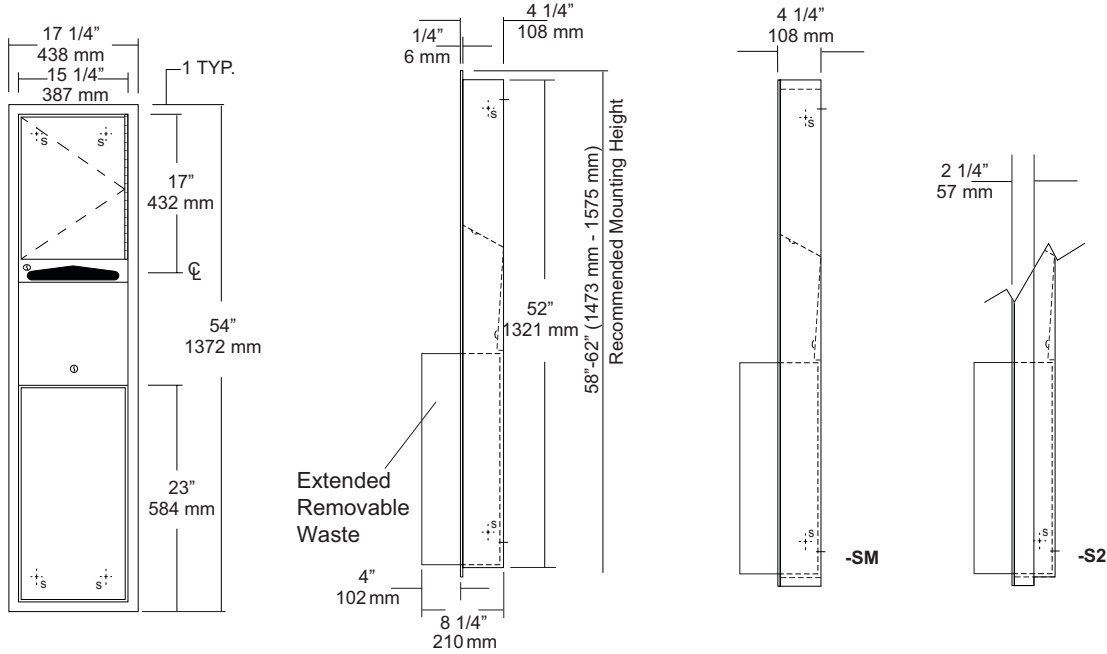

SPECIFICATIONS

Body: Fabricated of #22 ga stainless steel with a #4 satin finish.

Flange: Fabricated of #22 ga stainless steel finished to match cabinet with 1/4" returns. (No miters or welds)

Cabinet Back: Fabricated of stainless steel formed for rigidity with multiple welds to cabinet body.

Cabinet Door: Fabricated of #22 ga stainless steel with #4 satin finish.

Towel Dispenser: Fabricated of #22 ga stainless steel with hemmed edges to prevent injury and towel tearing.

Removable Waste: Fabricated of #22 ga stainless steel #4 satin finish with all leading edges to have a radius. Unit is secured in place by a bottom bracket guide and top lock.

Hinge: Full length, heavy duty, stainless steel piano type hinge.

Locks: Pin tumbler commercial quality, keyed like all other AJW cabinets.

Collars: Fabricated of #22 ga stainless steel, finished to match cabinet. (Used when full recessing cannot be accomplished)

Overall Size: 17 1/4"W x 54"H x 8 1/4"D
438mm x 1372mm x 210mm

Wall Opening: 15 3/4"W x 52 1/2"H x 4"D
400mm x 1334mm x 102mm

U650-S2: semi-recessed. with 2" collar, 2" wall opening 51mm

U650-SM: Full surface mounted collar.

Towel Capacity: 600 c-fold or 800 multifold

Waste Capacity: 12 gallons (1.6 cu ft)

Options :

-VL1: Vinyl Liner

INSTALLATION

Coordinate installation with architect and contractor to avoid interference with pipes, vents, etc. Provide a rough wall opening 15 3/4"W x 52 1/2"H. See chart for required wall depth. If collar is required, slide collar over the back before installing into wall. Remove waste from cabinet and mount unit plumb and true in opening with proper fasteners per application. Secure waste in cabinet and load paper towels.

When cleaning cabinet use a non abrasive non-chloric solution and wiped off with the grain of the cabinet.

NOTES

JOB #:

ITEM #:

QUANTITY:

MOUNTING	HANDING	TYPE	SIZE	OTHER

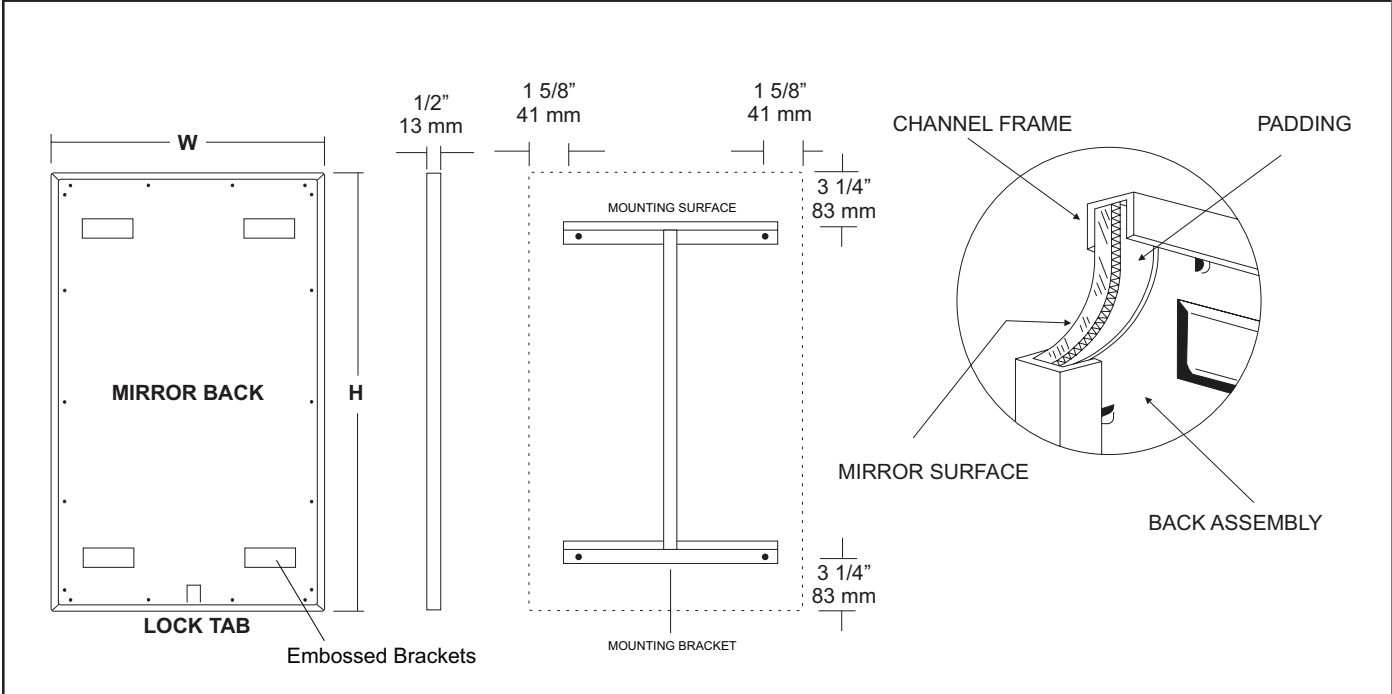

SPECIFICATIONS

Frame: Fabricated of #20 ga stainless steel, #4 satin finish. Roll formed $1/2" \times 1/2" \times 1/2"$ channel frame has mitered corners and secured with stainless steel rivet.

Mirror: $1/4"$ thick type 1 transparent flat type, class 1 - clear glass mirrors. Mirror is coated with silver and sealed with a uniform electrolytic copper plating, along with two coats of paint for added protection. Mirrors are guaranteed against silver spoilage for a period of 15 years. Mirrors conform to ASTM C1036 and ASTM C1503-R8.

Filler: Full size, $1/8"$ shock absorbing, water resistant, nonabrasive, polyethylene padding protects all concealed mirror surfaces.

Back: #20 ga pre-plated galvanized steel, with embossed horizontal louver mounting brackets. Embossed theft resistant pressure activated clip lock device, locks mirror in place to wall hangers.

Hangers: Fabricated of #20 ga pre-plated steel galvanized steel with mounting points.

Standard Sizes Available (W x H): 16"x20", 16"x24", 16"x30", 18"x24", 18"x30", 18"x36", 24"x30", 24"x36", 24"x42", 24"x48", 18"x60", 20"x60", 24"x60", 18"x72", 24"x72"

Options:

- LG:** Laminated Glass
- LX:** Polycarbonate
- PM:** Plastic Acrylic
- T:** Tempered Glass
- VC:** Vinyl Clad (Safety Glass)
- 8B:** #8 Reflective Stainless Steel

*Stainless steel mirrors reflect images in different optic quality than plate glass. There will be a slight distortion which increases proportionately with the mirror size. Therefore, AJW Architectural Products™ cannot be held responsible for quality of image.

- **Mirrors are always ordered Width x Height
- ***Recommended max size for 8B mirrors: 72" x 47-1/2"
- ****Framed mirrors are fabricated to a tolerance of (+/-) 1/8"
- ***** Mirrors conform to Federal Specifications DD-M-00411b & DD-g-541D

INSTALLATION

Coordinate installation with architect / contractor for specific mounting location and height for each mirror application. Making sure "I" bracket is level, transfer all mounting point locations to wall surface from drawing. Secure brackets with proper fasteners for each application. Slide mirror down over horizontal brackets until clip lock secures mirror in place. Mirror can only be removed by inserting tool through hole at bottom of frame depressing clip. This will allow mirror to slide up over brackets. Fillers are available if mirrors are mounted above and below tile line. (U004 Filler) filler material will match mirror frame to form a one piece construction.

To meet ADA Code, bottom edge of reflective surface can be no higher than 40" above finished floor. (4.19.6) Full length mirrors may be used for universal application when installed in correct locations.

Abrasive cleaners & chloric solutions should not be used on mirrors. Discoloring and /or scratching of frame and reflective surface may occur.

NOTES



U775 Series

Surface Mounted Shelf

Revision 07/11

JOB #:

ITEM #:

QUANTITY:

MOUNTING	HANDING	TYPE	SIZE	OTHER

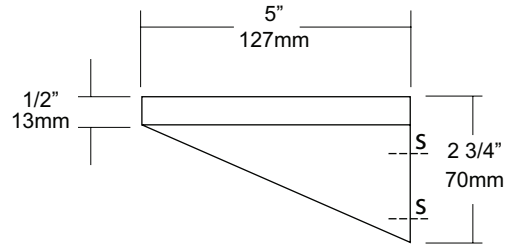
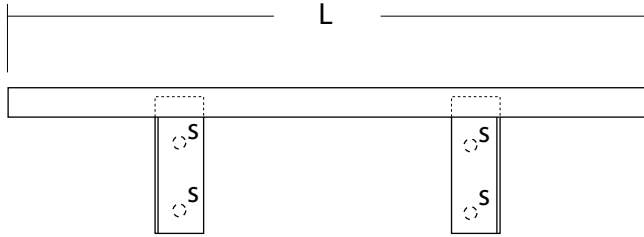

SPECIFICATIONS

Shelves: Fabricated of #18 ga stainless steel. All edges are turned down 1/2" with front edges turned down & back 1/2" for maximum strength and rigidity. All corners are deburred and polished smooth for safety.

Brackets: Fabricated of #16 ga stainless steel permanently welded to shelf with exposed mounting points. Brackets are spaced maximum 30" centerline.

Surface mounted shelf 5"D (127mm)

INSTALLATION

Provide an area on wall surface at desired or specified location. Place unit up to wall making sure unit is level. Transfer mounting points to surface and drill pilot holes. Secure shelf to surface with proper fasteners per each application.

NOTES



U806

Toilet Tissue Dispenser

Revision 03/11

JOB #:

ITEM #:

QUANTITY:

MOUNTING	HANDING	TYPE	SIZE	OTHER
----------	---------	------	------	-------

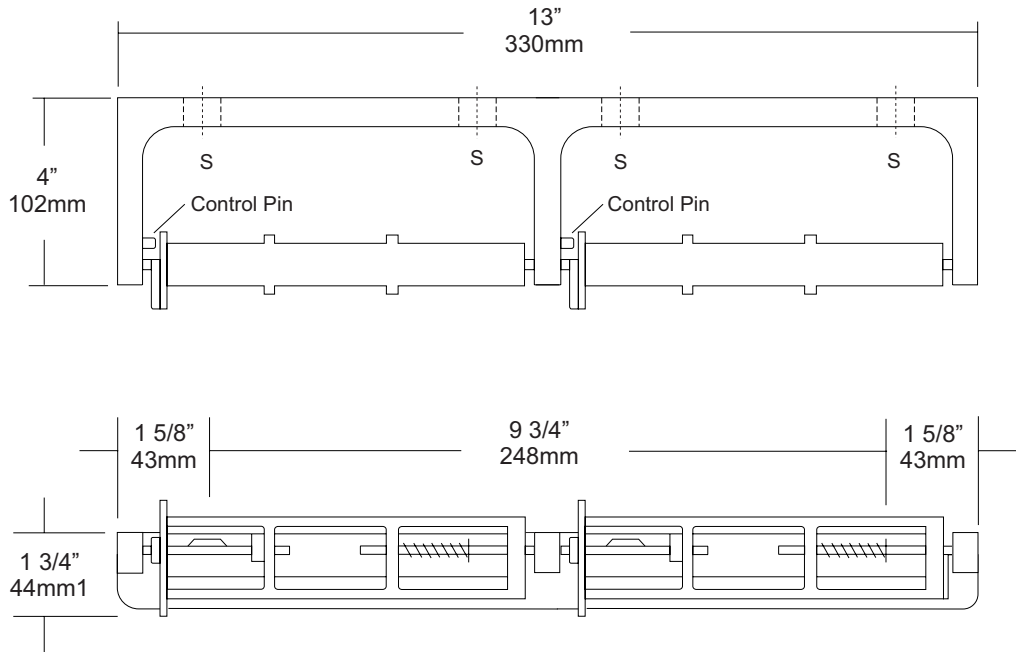

SPECIFICATIONS

Mounting Bracket: Fabricated of heavy duty, die cast aluminum alloy, satin matte finish. One piece formed construction provides maximum strength and rigidity.

Spindles: Molded high impact ABS material (theft resistant) with stainless steel spring, designed to retain spindles on bracket. Spring loaded pin prevents roll from being removed until roll is depleted. Spindle rotates only 1/2 revolution.

Control Pin: Stainless steel pin provides dispenser a control delivery. On the -NC units (non-control) the pin is removed. This can be removed at the factory or in the field.

Overall Size: 13"W x 1 3/4"H x 4"D

330mm x 45mm x 102mm

Capacity: Two standard rolls with a 5 1/4" (133mm) OD.

U806-NC: Same as U806 with non-controlled delivery to comply with ADA code

INSTALLATION

Provide an area on wall surface at desired or specified location. Place unit on mounting surface making sure unit is level and transfer mount points. Drill pilot holes and secure with proper fasteners per application. If a controlled delivery dispenser is installed, remove spring loaded pin to obtain a non-controlled delivery. All dispensers must have a non-control delivery, be mounted at the proper height and location to meet ADA code. (4.16)

NOTES



UG2-A

Grab Bars

Revised 03/11

JOB #:

ITEM #:

QUANTITY:

MOUNTING	HANDING	TYPE	SIZE	OTHER

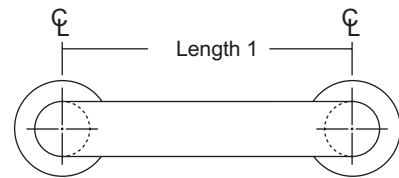
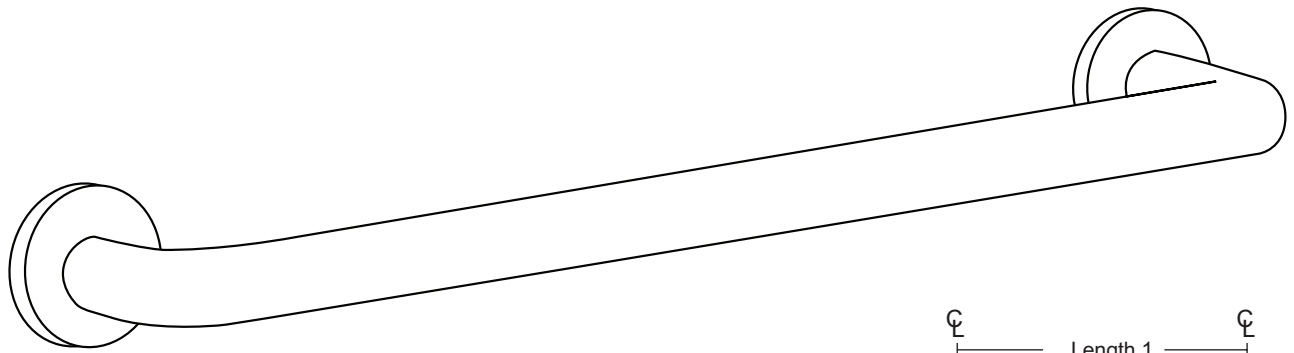

SPECIFICATIONS & INSTALLATION

Tubing: Fabricated of #18 ga stainless steel with a #4 satin finish. Available in 1 1/4" outside diameter. All bends are formed by an automatic mandrel bending process. All bars maintain a constant 1 1/2" offset.

Finish: Standard finish is a #4 satin finish. For a non-slip finish (peened) add suffix X to model number. (Ex. UG2X-A)

Flanges: Snap flanges are fabricated of 3" diameter, 3/8" deep drawn #22 ga stainless steel with #4 satin finish to match tubing. Flanges have dimples that secure over mounting plate.

Strength: Bars with a 1 1/2" offset clearance will support loads in excess of 900lbs when properly installed. Bars with greater offsets will support loads up to 250lbs when properly installed.

Installation: Before installing grab bars, verify with all state and local codes for requirements on bar diameter and type finish. Recommended mounting heights for grab bars are 33" - 36" centerline above finished floor. All mounting of grab bars when possible should have in wall mounting back plates. Find centerline mounting points and place bar on line making sure to be on center. Transfer mounting points (3 per flange) to wall. Drill pilot holes and secure bar with proper anchors per application. Snap cover over mounting plate.

Standard Lengths (Other sizes available upon request): 12", 16", 18", 24", 30", 32", 36", 42", 48", 50", 52", 54", 56"

FLANGE INFORMATION

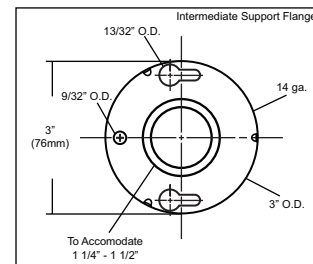
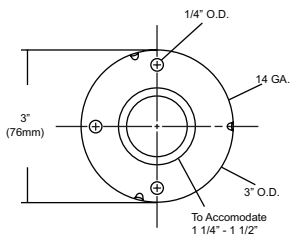
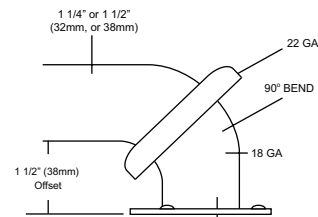

NOTES