

date
projectname
attn
from
fax
email
phone

9/2/21
Contract B building 4224
Matt

Care, Cleaning, and Maintenance Instructions – Washroom Accessories

With proper care and cleaning, as well as routine maintenance, you will help to maximize the life of your AJW accessories. Please refer to these procedures when maintaining our products:

Stainless Steel Surfaces:

Wipe stainless steel cabinets with a soft cloth, rubbing with the grain to prevent scratching the surface. The grain of AJW's stainless steel cabinets runs in a vertical direction. Do not use abrasive cleaners containing chloric solutions on stainless steel. Avoid cleaning products that contain hydrochloric acids, bleach, or chlorides.

Soap Dispensers:

The majority of operational issues with soap dispensers are due to improper maintenance and lack of cleaning. Soap tanks, valves, and globes should be cleaned periodically to avoid sludge and soap build up, thus promoting better operation. When soap dispensers are left unmaintained for long periods of time, the soap could potentially dry out inside the valve mechanism, causing clogs or leaking. While cleaning, do not remove or take valves apart as this creates problems with the seals and may cause a bypass leak. Flush valves with warm water. If the water does not flow through the valve after cleaning, repeat the procedure until it does.

Take care to make sure you are using the right soap in your soap dispensers. The proper viscosity is imperative for trouble free operation. AJW recommends that the soap viscosity should be at least 95 cps, and no more than 2500 cps for use in all AJW soap dispensers. Coconut oil soaps should be the only products used in liquid valve soap dispensers. We recommend that you use a standard liquid, non-chloric soap, which should be mixed in a solution of one part water to one part soap. We recommend free-flowing, thin viscosity soaps only.

JetAir Hand Dryers:

Begin the cleaning procedure by disconnecting the electrical supply. Using the allen key supplied, remove all tamper-resistant screws and lift the cover of the dryer off of the base, and clear dust and lint from the inside of the machine and cover. When you have finished cleaning, reinstall the cover onto the base and secure with tamper-resistant screws. Wipe cover with a damp cloth; do not use abrasive cleaners. Clean the inner cover and internal mechanism periodically to ensure proper operation.

Note: Hand Dryer maintenance that is performed inside the cover should not be done by unqualified personnel.

Mirrors:

Wipe mirror frames with a soft cloth, making sure to rub stainless steel frames with the grain to avoid scratching. Do not use abrasive cleaners containing chloric solutions on stainless steel frames.

Mirror glass should be cleaned by spraying cleaner on a soft cloth, and then wiped onto the mirror (it is best if cleaner is not sprayed directly onto the mirror). This will ensure that cleaning agents do not run down the mirror and into the frame. If a cleaning agent and/or still water is allowed to sit in a frame or on the back of a mirror, it will lead to a de-lamination of the protective coating, and/or the mirror silver, voiding the AJW warranty.

Note: Soap dispensers should not be mounted directly on a mirror surface, as soap residue and water from a person's hand can be splashed into the mirror frame, causing the same de-lamination as described above.

Corrosive Chemical / Surface Rust Alert

Stainless steel is very resistant to rust, however it is not entirely impervious to it. Proper care, especially under corrosive conditions is needed. Cleaning your stainless steel surface using the instructions above is necessary, but it is also important to keep your stainless steel surface free from contaminants.

The below listed substances will react with stainless steel to produce rust and corrosion. These elements are commonly used in caustic cleaning agents, and should never be used to clean stainless steel washroom accessories. The most common elements that react adversely with stainless steel include:

Bromide
Chloride
Fluoride
Iodine

Other common acids and compounds cause significant damage to stainless steel. Stainless steel will sustain permanent discoloration and/or corrosion if the material comes into contact with even vapor fumes from these substances. The following acids and compounds should never be used to clean any stainless steel product:

Acetic Acids
Nitric Acids
Phosphoric Acids
Hydrochloric / Muriatic Acids
Sodium Chlorides (contains salt)
Sodium Hydrochloride (Bleach)
Sodium Hydroxide
Sulfuric Acids



Some other conditions that can cause stainless steel to corrode, discolor, or develop surface rust are:

1. Contact with Muriatic Acid (commonly used to clean up after tile or concrete installation).
2. Soap residue (chemical additives will cause discoloration and dried soap residue actually looks like rust).
3. Water with high iron content can leave a rusty residue, especially after continuous contact.

Surface Rust Removal

If your stainless steel surface is exposed to any of the contaminants above, please follow the instructions below to remove any discoloration:

- Wash affected accessory with a mild dish detergent and warm water.
- Dry all surfaces with a towel or soft cloth.
- Using a dry Scotch Brite pad, rub all surfaces until rust marks are completely removed. Be sure to rub in the direction of the grain to prevent scratching. Grab bars may be cleaned using a rotating motion, as the grain is random in these products. Do not use on bright polish stainless steel.
- Rinse with a damp cloth and dry with a soft cloth.



U126 Soap Dispenser

Revision 11/14

JOB #:

ITEM #:

QUANTITY:

MOUNTING	HANDING	TYPE	SIZE	OTHER

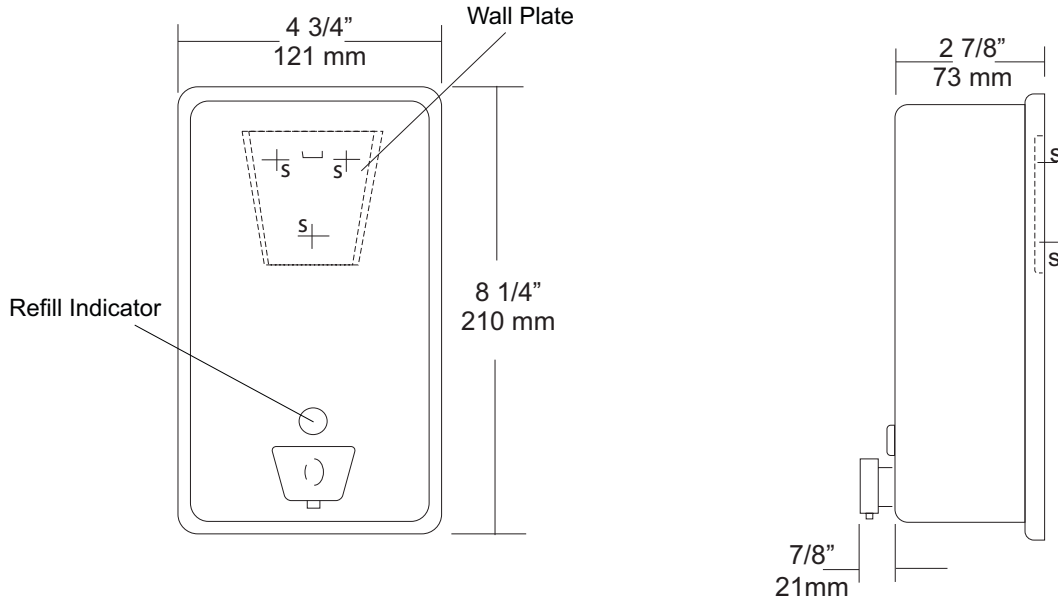

SPECIFICATIONS

Soap Tank: Fabricated of #20 ga stainless steel, #4 satin finish, fully welded one-piece construction.

Valve: All purpose antibacterial soap valve cylinder, black molded plastic push style valve that takes less than 5 lbs of force and one hand to operate complies with barrier free guidelines when mounted at proper height.

Viewer: Clear plastic window allows a constant fluid level check.

Concealed Mounting Plate: Fabricated of heavy gauge stainless steel.

Filler Cap: Fabricated of stainless steel, hinged to allow easy servicing, secured with special key that creates a vandal resistant dispenser.

Overall Size: 4 3/4"W x 8 1/4"H x 3 3/4"D (wall to valve)

121mm x 210mm x 95mm

Capacity: 40 oz.

Recommend type soaps without chloric solutions for proper operation.

INSTALLATION

Provide an area on mounting surface at desired or specified location. Secure concealed mounting plate to wall surface with proper fasteners. Slide dispenser down over mounting plate and secure by means of set screw located inside tank. Fill unit with proper soap. Close lid and secure with special key. Test valve for proper operation.

*It is not recommended to mount any soap dispenser on mirrors

**For best performance, use pre-mixed low concentrate solutions. Dispensers should have periodic maintenance performed to insure the life dispenser. Rinse out globe and valve with warm water to avoid sludge buildup.

Preventative Maintenance: Each dispenser should be flushed out aprx. Every 30 days with warm water to prevent valve from clogging with old soap. Do not use abrasive cleaners to clean dispenser.

NOTES



U1521EA Series

Stainless Steel Hands Free Dryer

Revision 11/14

JOB #:

ITEM #:

QUANTITY:

MOUNTING	HANDING	TYPE	SIZE	OTHER

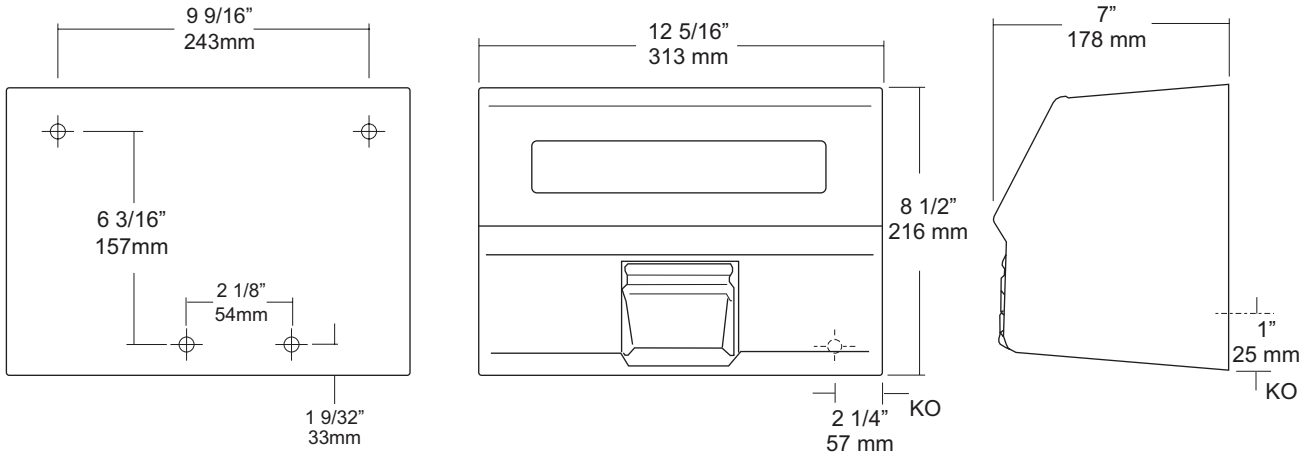

SPECIFICATIONS

Motor: Brushless, 1/8 hp, 3450 RPM capacitor initiated with non-lubricating bearings and thermally protected against over heating. 66.1 dB.

Fan: Dynamically balanced to eliminate vibration & noise.

Heating Element: Dynamically balanced to eliminate vibration & noise. 2300 watt nichrome coil would element on state of the art convective cooling system. Ambient temp produced at nozzle is 70 degrees F.(21 C) Unit is protected by an integral thermal safety circuit breaker.

Timer: Fully enclosed, non-mechanical timer, that automatically turns off when hands are moved away from path of sensor.

Electric Eye: Sensor allows a hands free operation. When sensor beam path is disturbed, dryer will automatically turn on. When hands move away from beam, dryer stops.

Cover: Fabricated of #18 ga stainless steel, #4 satin finish, spot welded to form one piece unibody construction. Cover is secured to base with two tamper resistant fasteners. Special key provided to remove cover. All seams polished smooth.

Nozzle: Fixed chrome plated nozzle that can be changed from fixed to 2 position in the field.

Base: One piece #14 ga steel with 3/4" returns to wall surface for maximum strength and rigidity.

Unit	Volts	Amps	Cycles	Cover
U1521EA	120V	110-120	20 60	S/S
U1521EA	230V	220-230	10 60	S/S

Overall Size: 12 5/16"W x 8 1/2"H x 7"D
313mm x 216mm x 178mm

INSTALLATION

Coordinate installation with contractor, architect and licensed electrician. Transfer mounting points to wall surface with supplied templates. Check all code requirements for proper mounting heights. Secure base with proper fasteners for each application. Properly connect power supply to dryer. Test dryer for operation. Secure cover to base with supplied theft resistant fasteners(2). Test dryer again after cover is secured. Dryers have a full five (5) year warranty to original purchaser against defective materials and workmanship. Unit must be installed by a qualified licensed electrician.

Mounting	Hands	Hair
Men	46" (1168mm)	73" (1854mm)
Women	44" (1118mm)	68" (1727mm)
Physically Impaired	38" (965mm)	46" (1168mm)
Children 6-10	34" (864mm)	43" (1092mm)
Children 11-14	42" (1067mm)	56" (1422mm)

*Above are recommended mounting heights from lower mounting point above the finished floor.

NOTES

Formerly Model #: U1521EA



U580
 Partition Mounted Sanitary Napkin
 Disposal
 Revision 09/13

JOB #:
 ITEM #:
 QUANTITY:

MOUNTING	HANDING	TYPE	SIZE	OTHER
----------	---------	------	------	-------

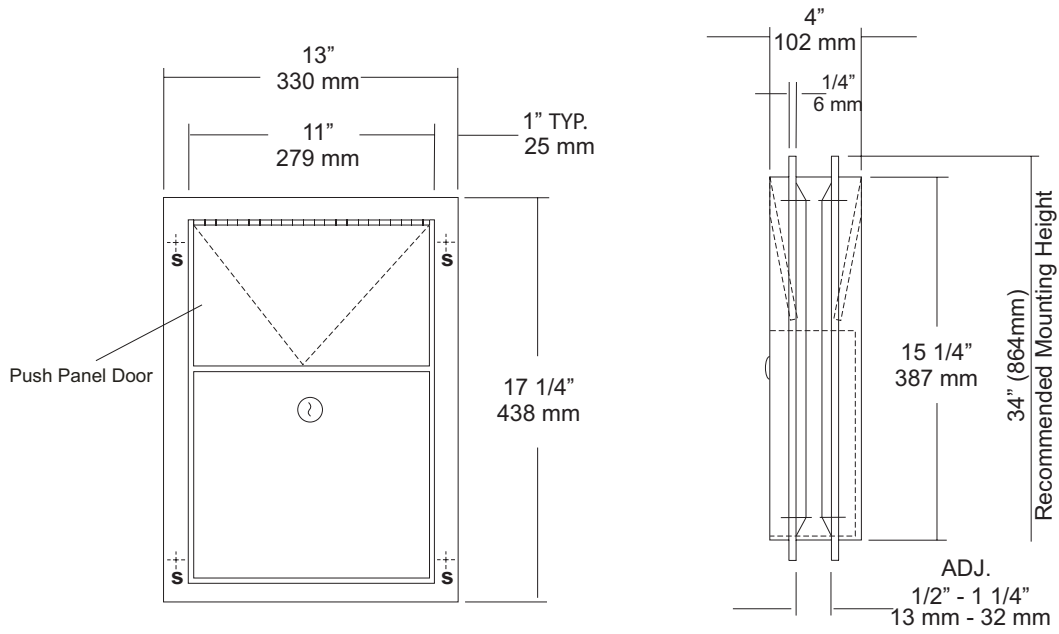

SPECIFICATIONS

Body: Fabricated of #22 ga stainless steel, #4 satin finish.
Flanges: Fabricated of #22 ga stainless steel, drawn one-piece construction with 1/4" returns to wall surface. One flange is welded to body the other is adjustable to fit 1/2" - 1 1/4" thick partitions. (No miters or welds).
Push Panels: Fabricated of #22 ga stainless steel self closing push panel door. *International graphic symbol optional*
Waste: #22 ga stainless steel removable from one side with pin tumbler type lock securing in place. Optional finger grip in lieu of lock
Locks: Pin tumbler locks keyed like all other AJW cabinets.
Hinges: Full length, heavy duty, stainless steel piano type.
Overall Size: 13"W x 17 1/4"H x 4"D
330mm x 438mm x 108mm
Wall Opening: 11 1/2"W x 15 3/4"H
292mm x 400mm
Capacity: 1.5 gallons (.2 cu ft)
NDL-13-50: Waxed disposable liners. (50 per Case)
U580-PW: Same as U580 with plastic removable waste.

INSTALLATION

Provide a rough partition opening 11 1/2"W x 15 3/4"H. Remove adjustable flange and place unit into opening. Secure welded flange to partition at four points making sure unit fits flush and is level. Place adjustable flange over unit and secure to partition the same way as the fixed flange. Be sure the proper fasteners are used for each application.

NOTES



U670EA

Roll Towel & Waste Combination Unit

Revision 10/14

JOB #:

ITEM #:

QUANTITY:

MOUNTING	HANDING	TYPE	SIZE	OTHER

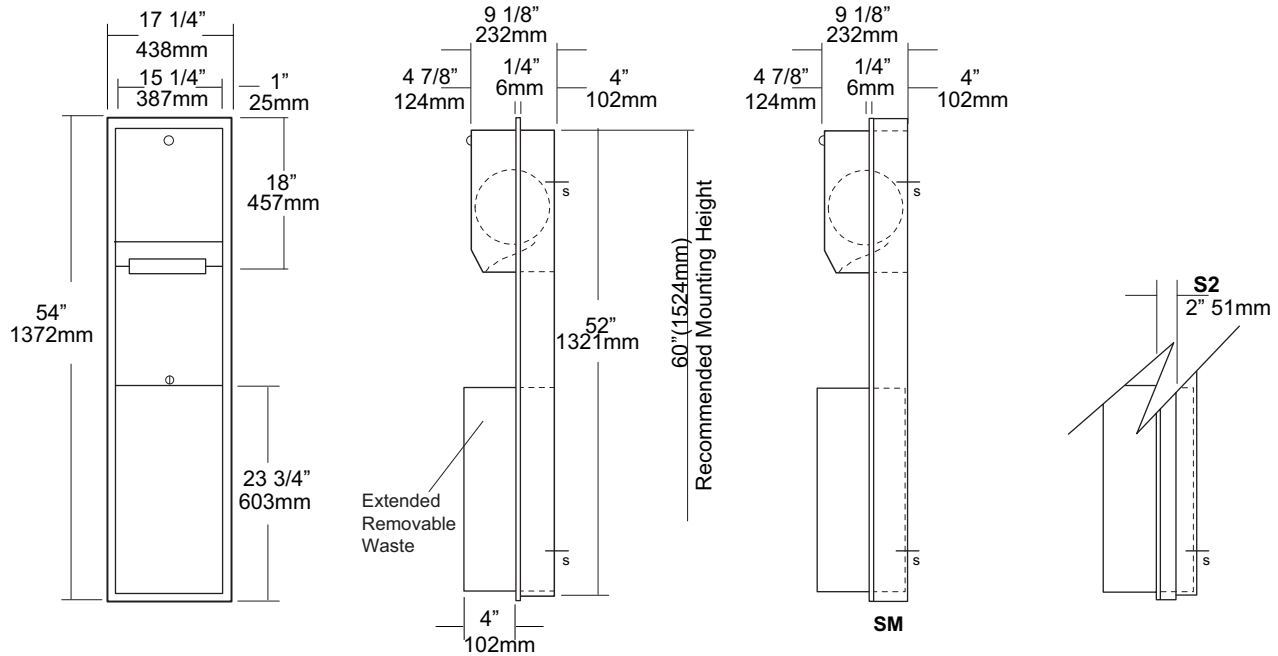

SPECIFICATIONS

Body: Fabricated of #22 ga stainless steel with a #4 satin finish.

Flange: Fabricated of #22 ga stainless steel finished to match cabinet with 1/4" returns. (No miters or welds)

Cabinet Back: Fabricated of stainless steel formed for rigidity with multiple welds to cabinet body.

Cabinet Door: Fabricated of #18 ga stainless steel with #4 satin finish.

Towel Dispenser: Sensor activated hands free roll towel dispenser operated by 4 "D" cell batteries (not included) Internal mechanism is fabricated of high impact plastic concealed inside stainless steel cabinet.

Removable Waste: #22 ga stainless steel #4 satin finish with all leading edges to have a radius. Unit is secured in place by a bottom bracket guide and top lock.

Hinge: Full length, heavy duty, stainless steel piano type hinge.

Locks: Pin tumbler commercial quality, keyed like all other AJW cabinets.

Collars: Fabricated of #22 ga stainless steel, finished to match cabinet. (Used when full recessing cannot be accomplished)

Overall Size: 17 1/4"W x 54"H x 4 1/4"D (wall depth req)
438mm x 1372mm x 108mm

Wall Opening: 15 3/4"W x 52 1/2"H
400mm x 1334mm

U670EA-S2: semi-recessed. with 2" collar, 4" wall opening 102mm

U670EA-SM: Full surface mounted collar

Waste Capacity: 12 gallons (1.6 cu ft.)

Towel Capacity: One standard size roll of 8" or 9" wide. (Use only non-perforated towels). One stub roll up to 2 3/4" OD

***Recommended 600ft roll for best results.**

Options:

- VL1: Reusable vinyl liner

INSTALLATION

Coordinate installation with architect and contractor to avoid interference with pipes, vents, etc. Provide a rough wall opening 15 3/4"W x 52 1/2"H. If collar is required, slide collar over the back before installing into wall. Remove waste from cabinet and mount unit plumb and true in opening with proper fasteners per application. Secure waste in cabinet. Unlock towel cabinet and install batteries per instructions inside cabinet. Load towels and test for proper operation. Sensor may need up to 6 cycling's for proper calibration.

When cleaning cabinet use a non abrasive non-chloric solution and wiped off with the grain of the cabinet.

NOTES

Formerly Model #: U650EA

JOB #:

ITEM #:

QUANTITY:

MOUNTING	HANDING	TYPE	SIZE	OTHER

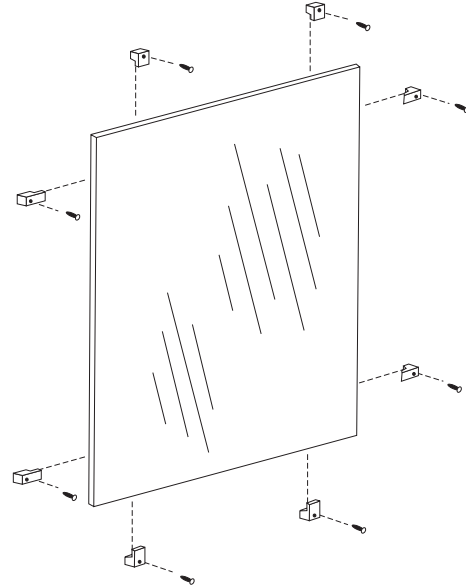
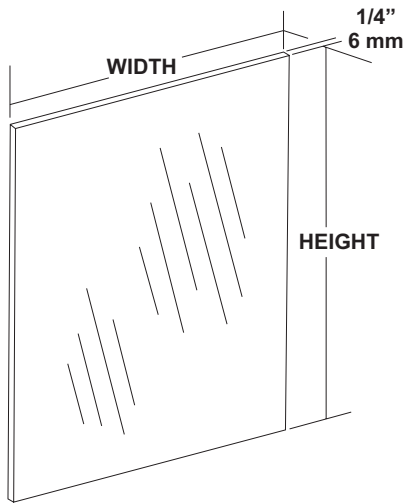

SPECIFICATIONS

Mirror: 1/4" thick type 1 transparent flat type, class 1 - clear glass mirrors. Mirror is coated with silver and sealed with a uniform electrolytic copper plating, along with two coats of paint for added protection. All frameless mirrors have polished edges. Mirrors are guaranteed against silver spoilage for a period of 15 years. Mirrors conform to ASTM C1036 and ASTM C1503-R8.

Recommended size one piece glass is 96" x 96"

Optional Surfaces and Sizes:

- PM: Plastic Mirrors (96" x 48" max size)
- LG: Laminated Glass (96" x 48" max size)
- BE: Beveled Edge Mirror: 1/4" plate glass with 1/2" Beveled Edge (72" x 60" max size)
- VC: Vinyl Clad (96" x 96")

***NOTE:** For oversized mirrors, recommend using U717 "J" mold style mirrors (Bottom, Top & Bottom or 4 sided) See U717 tech data sheet for more information.

Mounting Options:

- CL: Lucite Mirror Clips: (6 clips per pack)
- SCL: Stainless Steel Clips: (6 clips per pack)
- BCL: Lucite Mirror clips for beveled edge mirrors.

These Mirrors are always ordered Width x Height

Frameless mirrors are fabricated to a tolerance of ± 1/16"
Mirrors conform to Federal specification DD-M-00411b.

INSTALLATION

Provide an area on wall surface at desired or specified location. Select the proper clips for mounting. Mount the bottom clips approx. 1" in from each side of the overall width of the mirror. Place a level across the clips to make sure mirror will be level. Place glass on clips and check with level again. Follow same procedures for other clips. For oversized glass, it is recommended to have a minimum of a bottom "J" mold style mounting frame.

***Note:** Recommend 8 sq ft of glass per 1 pack of plastic clips. 8 sq ft of glass for stainless clips. The bottom reflective surface edge must be mounted 40" above finished floor to comply with ADA code, 4.19.6.

NOTES



U834

Jumbo Roll Toilet Tissue Dispenser

Revision 03/11

JOB #:

ITEM #:

QUANTITY:

MOUNTING	HANDING	TYPE	SIZE	OTHER

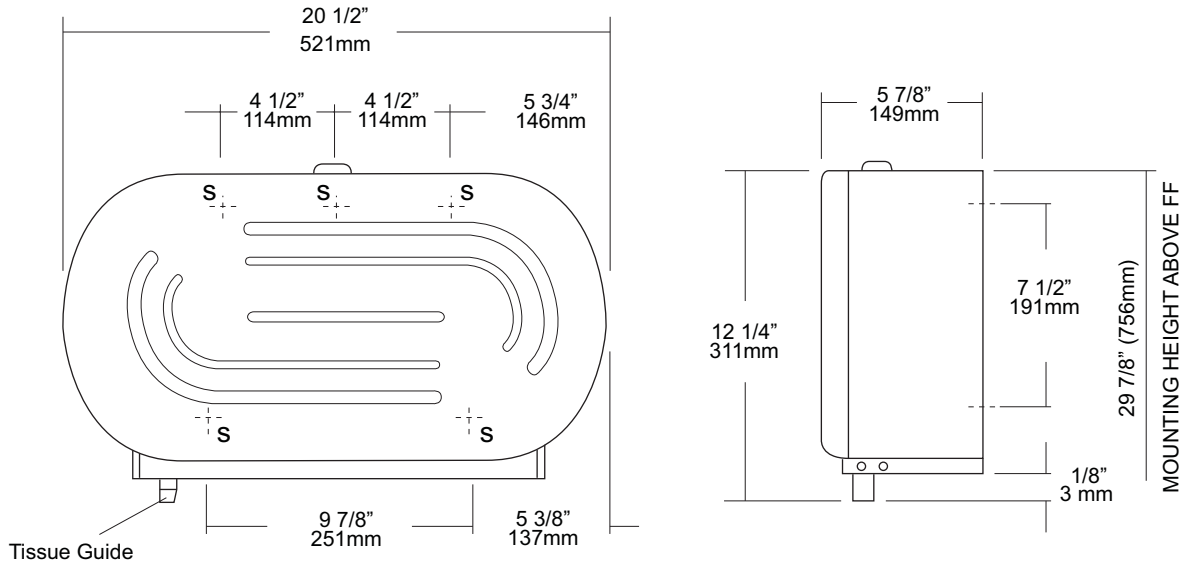

SPECIFICATIONS

- Body:** Fabricated of #20 ga stainless steel with a #4 satin finish with a smooth radius silhouette,
- Cabinet Door:** Drawn one piece construction, fabricated of #18 gauge stainless steel finished and grain to match cabinet body, Door is secured to body by means of oversized heavy duty rivets,
- Tissue Guide:** Spring loaded ABS guide,
- Spindles:** Unit will hold two 9" diameter rolls with a core diameter of 1 3/8" - 3 1/4" (Non-control delivery) by removing the outer spindle,
- Locks:** Commercial quality, pin tumbler lock.
- Overall Size:** 20 1/2"W x 12 1/4"H x 5 7/8"D
- 521mm x 311mm x 149mm**
- Capacity:** Two 9" OD (229mm) jumbo tissue rolls

INSTALLATION

Provide an area on wall at desired or specified location. Unlock cabinet and place unit on wall making sure cabinet is level. Transfer mounting points to surface and drill pilot holes. Secure unit with proper fasteners per application. Load toilet tissue on spindles and close cabinet.
 Toilet Paper Dispensers: All dispensers that are to meet ADA code cannot have any type of controlled delivery. (4.16)

NOTES



U851 Seat Cover Dispenser

Revision 07/15

JOB #:

ITEM #:

QUANTITY:

MOUNTING	HANDING	TYPE	SIZE	OTHER

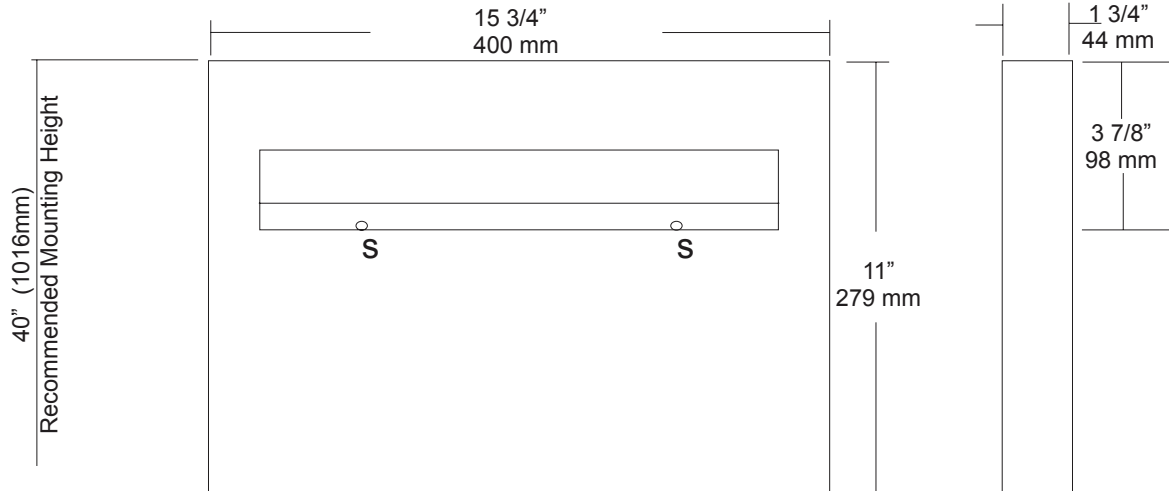

SPECIFICATIONS INSTALLATION

Dispenser: Unit is fabricated of #22 gauge stainless steel with a #4 satin finish. Beveled edge around the dispensing areas ensures a clean dispensing area that prevents product from tearing and injury. Loading of product is accomplished from below without having to open any locking mechanism or access panel. Hat style mounting bracket provides added rigidity for body and acts as a support for the packaging.

Overall Size: 15 3/4"W x 11"H x 1 3/4"D
400mm x 279mm x 44mm

Capacity: 500 seat covers

Place unit on wall surface at desired or specified location making sure unit is level. Transfer mounting point locations and drill pilot holes for mounting. Secure unit to surface with proper fasteners per application. Product loads from the bottom out of site from public view.

NOTES



UG2-A

Grab Bars

Revised 03/11

JOB #:

ITEM #:

QUANTITY:

MOUNTING	HANDING	TYPE	SIZE	OTHER



SPECIFICATIONS & INSTALLATION

Tubing: Fabricated of #18 ga stainless steel with a #4 satin finish. Available in 1 1/4" outside diameter. All bends are formed by an automatic mandrel bending process. All bars maintain a constant 1 1/2" offset.

Finish: Standard finish is a #4 satin finish. For a non-slip finish (peened) add suffix X to model number. (Ex. UG2X-A)

Flanges: Snap flanges are fabricated of 3" diameter, 3/8" deep drawn #22 ga stainless steel with #4 satin finish to match tubing. Flanges have dimples that secure over mounting plate.

Strength: Bars with a 1 1/2" offset clearance will support loads in excess of 900lbs when properly installed. Bars with greater offsets will support loads up to 250lbs when properly installed.

Installation: Before installing grab bars, verify with all state and local codes for requirements on bar diameter and type finish. Recommended mounting heights for grab bars are 33" - 36" centerline above finished floor. All mounting of grab bars when possible should have in wall mounting back plates. Find centerline mounting points and place bar on line making sure to be on center. Transfer mounting points (3 per flange) to wall. Drill pilot holes and secure bar with proper anchors per application. Snap cover over mounting plate.

Standard Lengths (Other sizes available upon request): 12", 16", 18", 24", 30", 32", 36", 42", 48", 50", 52", 54", 56"

FLANGE INFORMATION

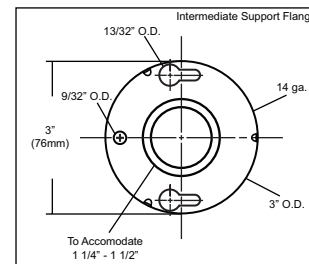
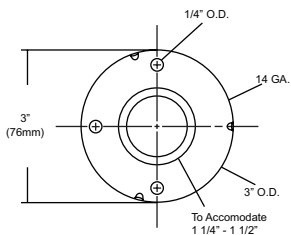
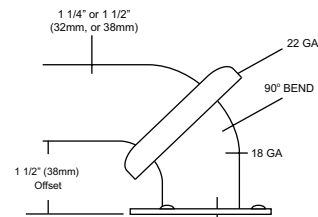

NOTES



UJ41 Series

Mop Holder & Hook Strip Combination Unit

Revision 03/11

JOB #:

ITEM #:

QUANTITY:

MOUNTING	HANDING	TYPE	SIZE	OTHER

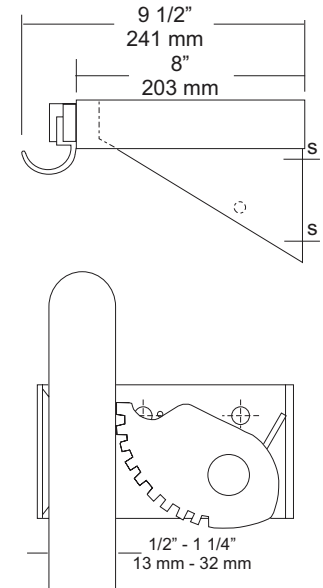
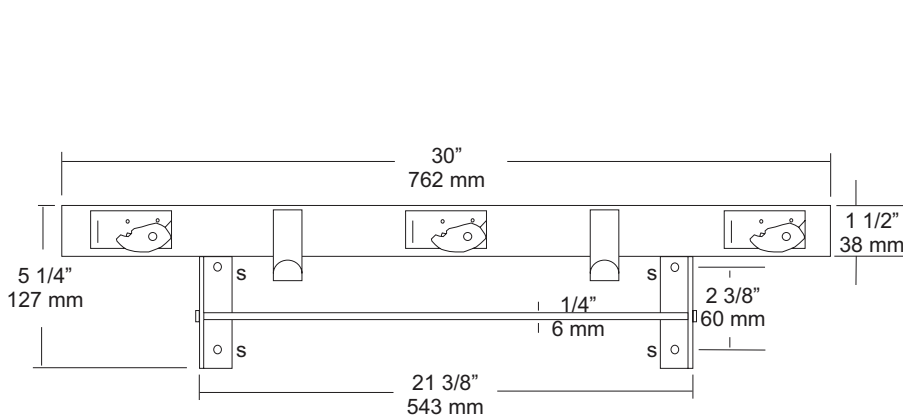

SPECIFICATIONS

- Shelf:** Fabricated of #18 ga stainless steel with a #4 satin finish, 8" deep (203mm) bent down 1 1/2" with 1/2" returns back for rigidity and safety.
- Mop Holders:** UJ19 plated reinforced steel with serrated cam type hard rubber mop or broom holder. Holds handles 1/2" to 1 1/4" diameter.
- Rag Hooks:** Fabricated of #18 ga stainless steel with a #4 satin finish.
- Mounting Brackets:** #16 ga stainless steel with exposed mounting points.
- Drying Rod:** 1/4" diameter stainless steel rod, secured to outside of support/mounting brackets with locking caps.
- Verify Style:**
- UJ41A:** 30"L (762mm) with 3 holders, 2 hooks.
- Rod Length:** 21 3/8" (565mm)
- UJ41B:** 36"L (914mm) with 4 holders, 3 hooks.
- Rod Length:** 27 3/8" (692mm)
- UJ41C:** 42"L (1066mm) with 5 holders, 4 hooks.
- Rod Length:** 33 3/8" (845mm)
- UJ41D:** 48"L (1219mm) with 6 holders, 5 hooks.
- Rod Length:** 39 3/8" (997mm)

INSTALLATION

Place unit to wall surface making sure unit is level and transfer mounting points. Drill pilot holes and secure unit with proper fasteners per application.

NOTES



Warranty – Washroom Accessories

Accessories

AJW guarantees its Washroom Accessories to be free of material defects, and defects from workmanship for a period of one (1) year from the date of shipment.

Baby Changing Stations

AJW baby changing stations are guaranteed for five (5) years from the date of shipment.

Mirrors

We guarantee our mirrors against silver spoilage for a period of fifteen (15) years under normal use. This guarantee includes all ¼” plate glass mirrors including tempered, laminated, and all other ¼” safety glass mirrors.

Hand Dryers

Our Jet Air hand dryers are warranted to be free of defects from workmanship under normal use and maintenance for a period of five (5) years from date of shipment (with the exception of the U1511EA which has a warranty period of two (2) years from date of shipment). Hand dryer warranty info is as follows:

- U1511EA- 2 Year Limited Warranty, Motor Brushes 2 Years, Eye Sensor One Year
- U1512EA- 5 Year Limited Warranty, Motor Brushes 2 Years, Eye Sensor One Year
- U1521EA- 5 Year Limited Warranty, Eye Sensor One Year
- U1525EA- 5 Year Limited Warranty, Eye Sensor One Year

This warranty excludes defects in the Washroom Accessory caused by: vandalism, improper use, improper installation, neglect, and environmental damage.

If the Washroom Accessory is found to be defective in workmanship or materials within the warranty period, AJW will replace all affected components, free of charge. AJW will not be responsible for any other expenses including, but not limited to: removal costs, installation costs, freight costs, or any other costs associated with the repair or replacement of the product.

The replacement or repair of defective material as stated in this warranty shall constitute the sole remedy of the buyer and the sole liability of AJW under this warranty. AJW shall not be liable for any incidental, consequential, or indirect damages caused by the failure or defect in the material supplied, or any delay in the replacement or repair of warranty items.

Warranty claims must be made during the warranty period, and communicated to AJW by contacting AJW Architectural Products at: 509 Temple Hill Road – New Windsor, NY 12553 – Phone: 845-562-3332.