

date
projectname
attn
from
fax
email
phone

09/24/2018
FBKS FCC GYM TOILET RENO
Cullen Mahaffey
David Burman
907-344-8658
david@northernofficesupply.com
907-644-9318



U811
Toilet Tissue Dispenser

Revision 03/11

JOB #:

ITEM #:

QUANTITY:

MOUNTING	HANDING	TYPE	SIZE	OTHER

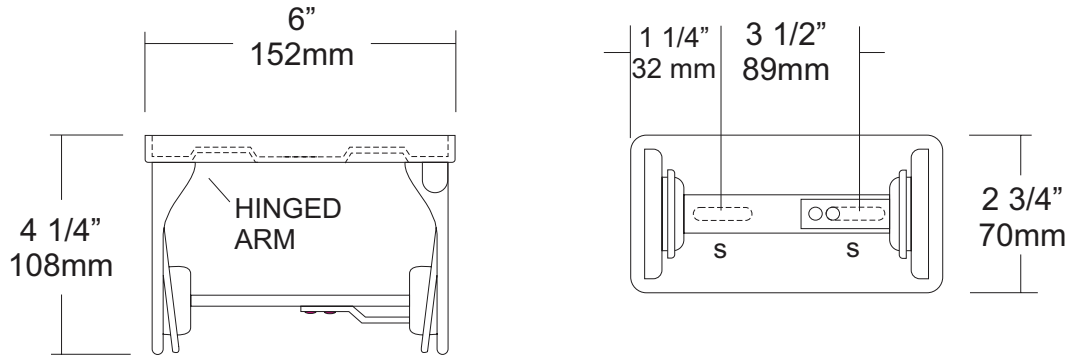

SPECIFICATIONS

Mounting Plate: Bright chrome plated #22 ga steel formed for maximum strength.
Arms: Hinged arms (one for each roll) are #22 ga bright chrome plated. The other arm is fixed. Both arms are fabricated with an extended support to maintain toilet tissue roll. This is a controlled type dispensing system.
Overall Size: 6"W x 2 3/4"H x 4 1/4"D
152mm x 70mm x 108mm
Capacity: One standard roll with a 5 1/4" (133mm) OD.

INSTALLATION

Provide an area on wall surface at desired or specified location. Hold unit to surface and make sure unit is level. Transfer mounting points to wall and drill pilot holes. Secure units with proper fasteners per application. Open units by depressing tab on spindle that allows arm to unlock. Load tissue on spindle and snap close.
 Toilet Paper Dispensers: All dispensers that are to meet ADA code cannot have any type of controlled delivery. (4.16)

NOTES



U925

Retractable Shower Seat

Revision 1/14

JOB #:

ITEM #:

QUANTITY:

MOUNTING	HANDING	TYPE	SIZE	OTHER
----------	---------	------	------	-------

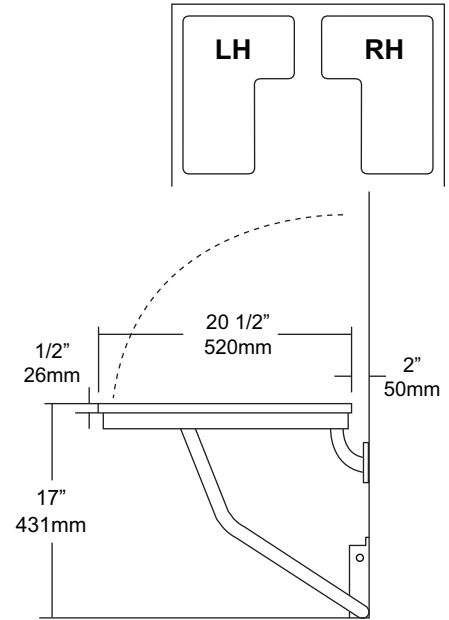
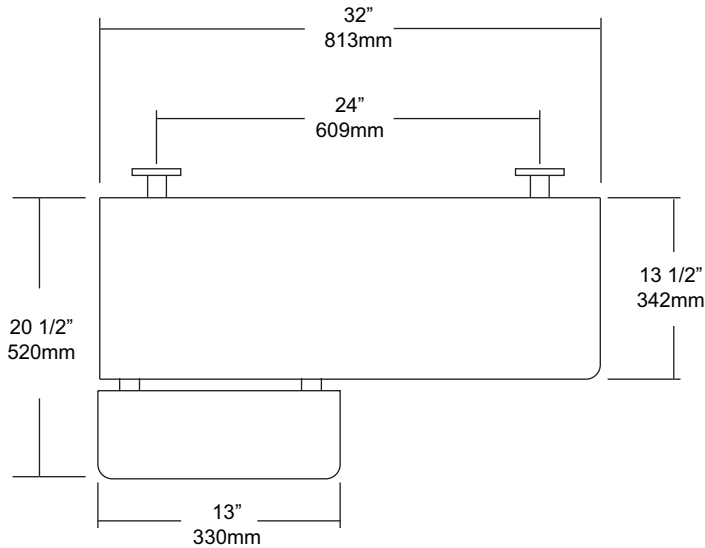

SPECIFICATIONS

Seat: Fabricated of #18 gauge #4 satin finish stainless steel welded to frame. All leading edges on slats have a radius edge for safety. Handing is required for this seat.

Tubing: Fabricated of #18 gauge stainless steel with a #4 satin finish.

Main Frame: 1 1/4" square tubing with capped ends. Underside has no exposed fasteners.

Flanges: Fabricated of #18 gauge stainless steel with four (4) exposed mounting points. Under slung supports have a 1 1/4"OD.

Leg Support: Fabricated of #18 gauge stainless steel one piece construction.

Mounting Bracket: #16 gauge stainless steel "hat" style bracket with four (4) mounting points. Bracket acts as a guide to raise and lower platform. For maximum support bracket should be mounted on finished floor to accept load transfer. Seat will remain in an upright position when not in use by means of a spring clip.

Overall Size: 32"W x 20 1/2"D (Seating Area) 813mm x 527mm

Handing:

U925-R: Right Handed

U925-L: Left Handed

INSTALLATION

To comply with ADA code, seat should be mounted at a height where the seating location should be at a height of 17" - 19" above finished floor. Check all State and Local code for building requirements. Recommend in wall mounting on all shower seats (BP10) for maximum strength. Place seat up against wall surface making sure seat is at the proper mounting height level. Transfer all mounting point locations and drill pilot holes. Secure seat with proper fasteners for each application. (Fasteners not provided, must be ordered separate) Snugly secure seat and check seat to be level and the raising and lowering of the seat does not bind. When all checks good, finish securing fasteners. When properly mounted seat will support over 500 lbs. To conform with ADA code 4.21.3 and 4.26.3

Note: This shower seat is not intended to be installed in applications that have shower bases with rounded corners. AJW recommends the U928 for such applications.

NOTES

Formerly Model #: U925-SS



US11
Security Toilet Tissue Holder

Revision 03/11

JOB #:

ITEM #:

QUANTITY:

MOUNTING	HANDING	TYPE	SIZE	OTHER

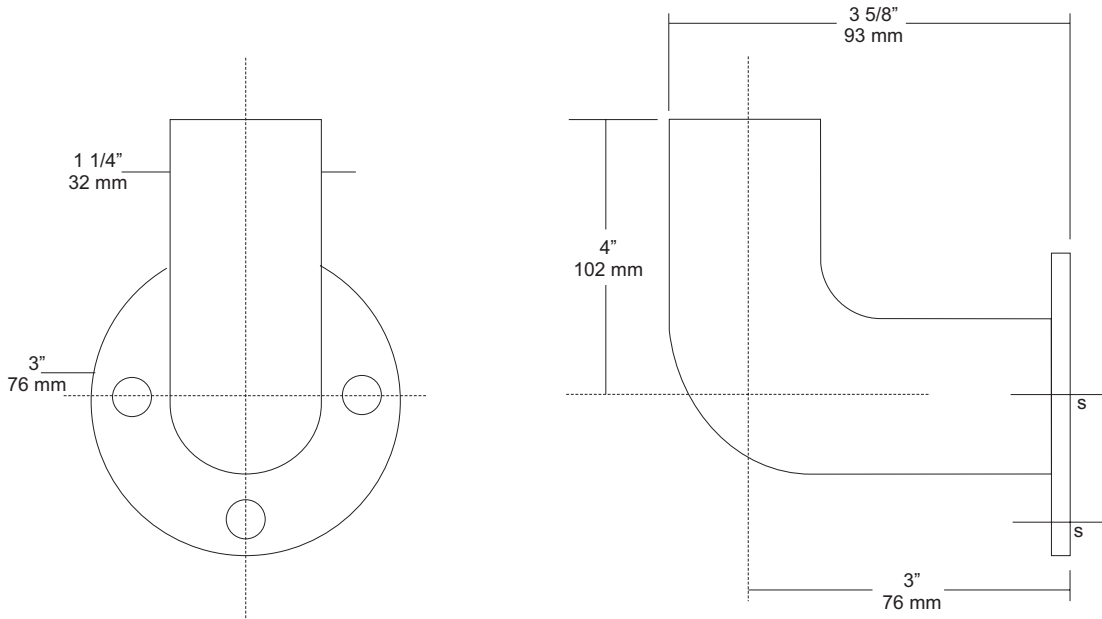

SPECIFICATIONS

Tubing: Fabricated of #18 gauge stainless steel with a #4 satin finish. Outside diameter of bar is 1 1/4" and is heliarc welded to mounting flange. Bar has a capped end that is welded and ground smooth to match the finish of the tubing.

Flange: Three inch (3") diameter exposed mounting flange with three exposed mounting points is fabricated of #11 gauge stainless steel with a finish to match the tubing.

Overall Size: 3"OD x 5 1/2"x 3 5/8"D

76mm x 140mm x 93mm

Capacity: One standard roll with a 5 1/4" (133mm) OD.

INSTALLATION

Place toilet tissue holder on wall surface and transfer mounting point locations. Drill pilot holes and secure with proper fasteners per each application. (Fasteners not included)

Toilet Paper Dispensers: All dispensers that are to meet ADA code cannot have any type of controlled delivery. (4.16)

NOTES



US130-A Series

Security Straight Grab Bar

Revision 09/11

JOB #:

ITEM #:

QUANTITY:

MOUNTING	HANDING	TYPE	SIZE	OTHER

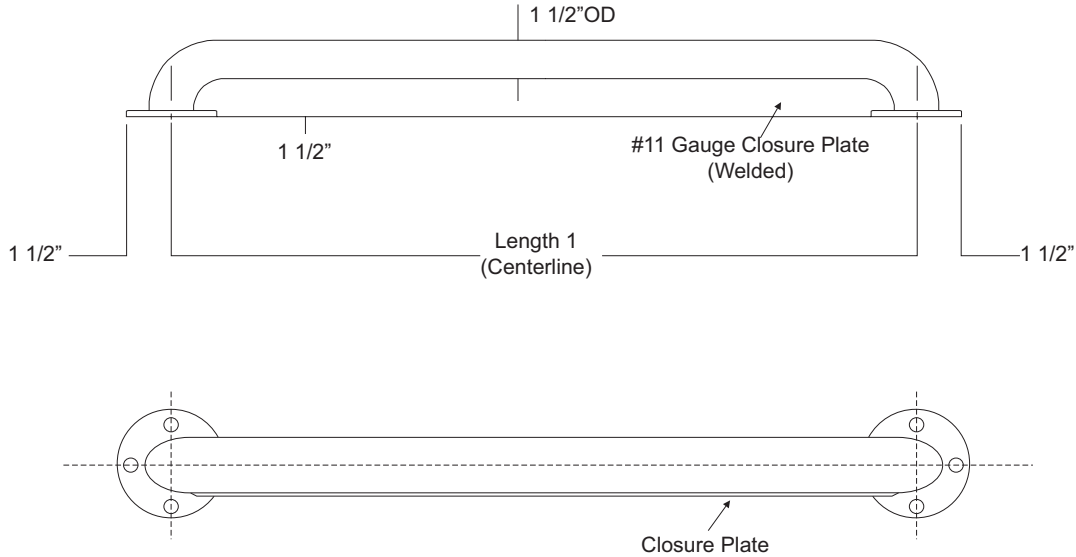

SPECIFICATIONS

Tubing: Fabricated of #18 ga stainless steel with a #4 satin finish and 1 1/2" outside diameter. All bends are formed by an automatic mandrel bending process. All bars maintain a constant 1 1/2" offset.

Flanges: Fabricated of 3" diameter, #11 ga stainless steel with #4 satin finish to match tubing. Flanges are heliarc welded to bar to form a one piece construction. Each flange has three (3) mounting points (1/4" dia.)

Closure Plate: Fabricated of #11 gauge stainless steel welded to the underside of the bar.

Strength: Bars that provide a 1 1/2" offset can support loads in excess of 900 lbs when properly installed. Other configurations can support loads excess of 250 lbs when properly installed. Grab bars must be installed properly to support the loads intended.

US130: Security Grab Bar, satin finish

US130X: Security Grab Bar, non-slip finish

"A" Style: 12" min. to 48" max. centerline dimension.

***When measuring and ordering grab bars, remember bars are sized centerline to centerline.**

***Grab Bars comply with ADA Code 4.26.2**

***Non-chloric and non-abrasive cleaners should be used to clean surface of bars and flanges.**

INSTALLATION

Before installing grab bars, verify with all state and local codes for requirements on bar diameter and type finish. Recommended mounting heights for grab bars are 33" - 36" centerline above finished floor. All mounting of grab bars when possible should have in wall mounting back plates. Find centerline mounting points and place bar on line making sure to be on center. Transfer mounting points (3 per flange) to wall. Drill pilot holes and secure bar with proper anchors per application.

NOTES



US18

Security Hook For Chase Walls

Revision 07/11

JOB #:

ITEM #:

QUANTITY:

MOUNTING	HANDING	TYPE	SIZE	OTHER

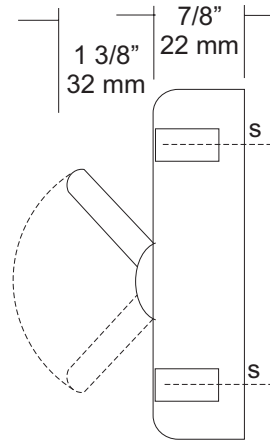
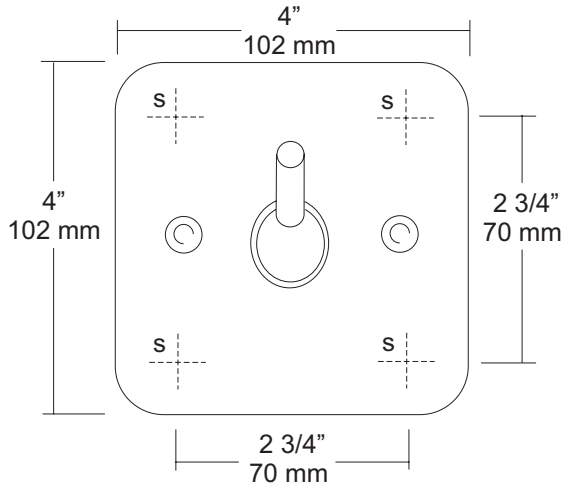

SPECIFICATIONS

Hook: Fabricated of #14 gauge stainless steel with a #4 satin finish. All seams are tig welded and ground smooth. Pivoting ball joint releases when excessive force is applied. (Aprx: 15lbs.) Back plate has weld nuts to receive 1/4"-20 studs. (Nuts and washers not included)

Overall Size: 4"W x 4"H x 2 1/4"D

102mm x 102mm x 57mm

INSTALLATION

Place hook on mounting surface and transfer mounting points at desired or specified location. Determine depth of wall to install threaded securing rod. Cut rod to desired length and secure with washers and nuts. (Nuts and washers not supplied) Chase wall installation.

NOTES



US740

Security Frameless Mirror

Revision 03/11

JOB #:

ITEM #:

QUANTITY:

MOUNTING	HANDING	TYPE	SIZE	OTHER

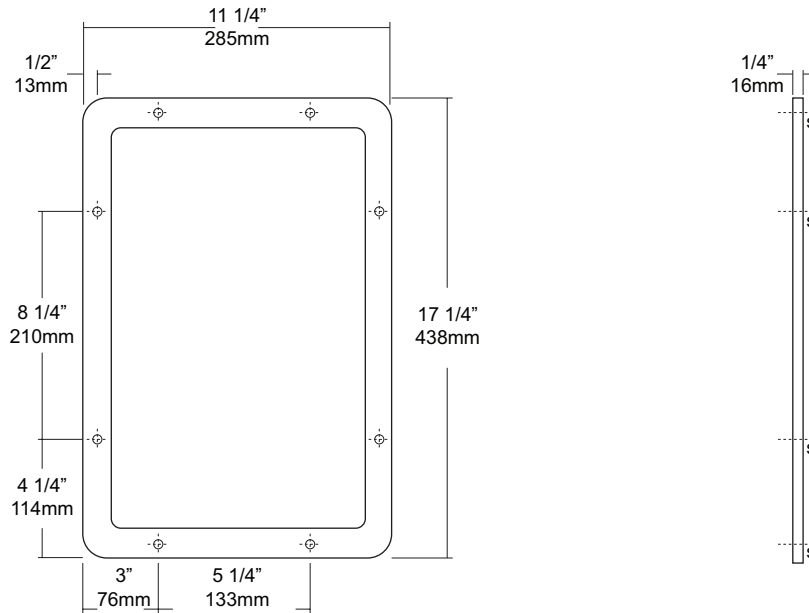

SPECIFICATIONS

Security Mirror: Fabricated of #18 ga stainless steel polished to a #8B finish. All exposed mounting points locations are countersunk. One piece design provides a rigid security mirror that has the appearance of a framed mirror.

Overall Size: 11 1/4"W x 17 1/4"H x 1/4"D
286mm x 438mm x 6mm

INSTALLATION

Place mirror on wall surface at desired or specified location. Making sure unit is level, transfer all mounting points to mounting surface. Drill pilot holes. Remove all white vinyl protective coating and secure with proper fasteners per application.

NOTES

Formerly Model #: US7408B