

date
projectname
attn
from
fax
email
phone

02-27-17
St. Luke's Rehab
Russ
Hardware Sales & Service
2083451528
dave@hssboise.com
2083451361



U925

Retractable Shower Seat

Revision 1/14

JOB #:

ITEM #:

QUANTITY:

MOUNTING	HANDING	TYPE	SIZE	OTHER

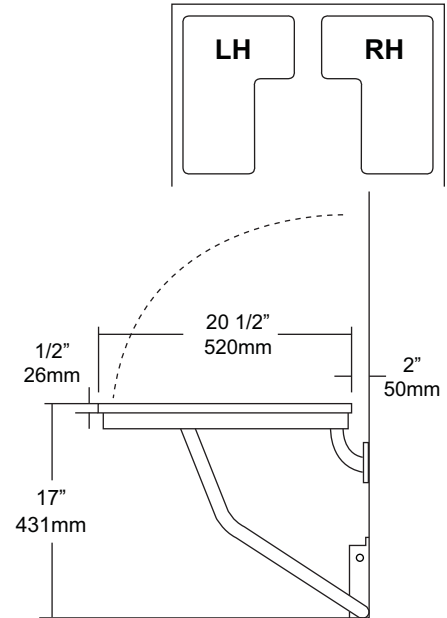
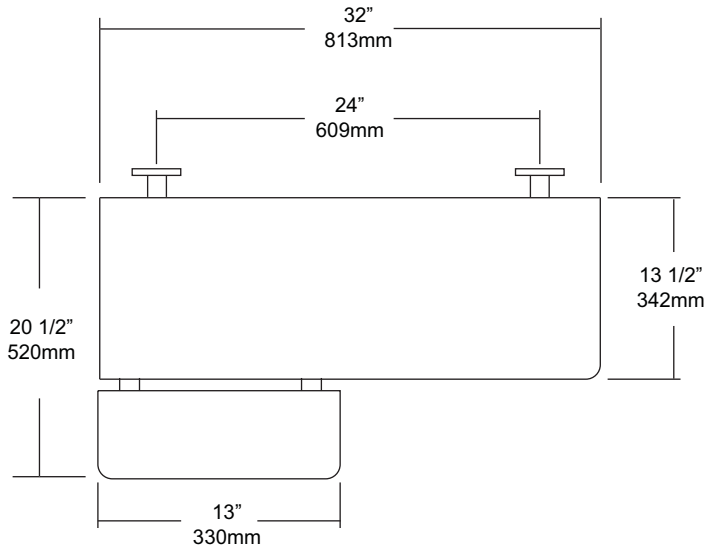

SPECIFICATIONS

Seat: Fabricated of #18 gauge #4 satin finish stainless steel welded to frame. All leading edges on slats have a radius edge for safety. Handing is required for this seat.

Tubing: Fabricated of #18 gauge stainless steel with a #4 satin finish.

Main Frame: 1 1/4" square tubing with capped ends. Underside has no exposed fasteners.

Flanges: Fabricated of #18 gauge stainless steel with four (4) exposed mounting points. Under slung supports have a 1 1/4"OD.

Leg Support: Fabricated of #18 gauge stainless steel one piece construction.

Mounting Bracket: #16 gauge stainless steel "hat" style bracket with four (4) mounting points. Bracket acts as a guide to raise and lower platform. For maximum support bracket should be mounted on finished floor to accept load transfer. Seat will remain in an upright position when not in use by means of a spring clip.

Overall Size: 32"W x 20 1/2"D (Seating Area) 813mm x 527mm

Handing:

U925-R: Right Handed

U925-L: Left Handed

INSTALLATION

To comply with ADA code, seat should be mounted at a height where the seating location should be at a height of 17" - 19" above finished floor. Check all State and Local code for building requirements. Recommend in wall mounting on all shower seats (BP10) for maximum strength. Place seat up against wall surface making sure seat is at the proper mounting height level. Transfer all mounting point locations and drill pilot holes. Secure seat with proper fasteners for each application. (Fasteners not provided, must be ordered separate) Snugly secure seat and check seat to be level and the raising and lowering of the seat does not bind. When all checks good, finish securing fasteners. When properly mounted seat will support over 500 lbs. To conform with ADA code 4.21.3 and 4.26.3

Note: This shower seat is not intended to be installed in applications that have shower bases with rounded corners. AJW recommends the U928 for such applications.

NOTES

Formerly Model #: U925-SS



U929

Retractable Shower Seat

Revision 1/14

JOB #:

ITEM #:

QUANTITY:

MOUNTING	HANDING	TYPE	SIZE	OTHER
----------	---------	------	------	-------

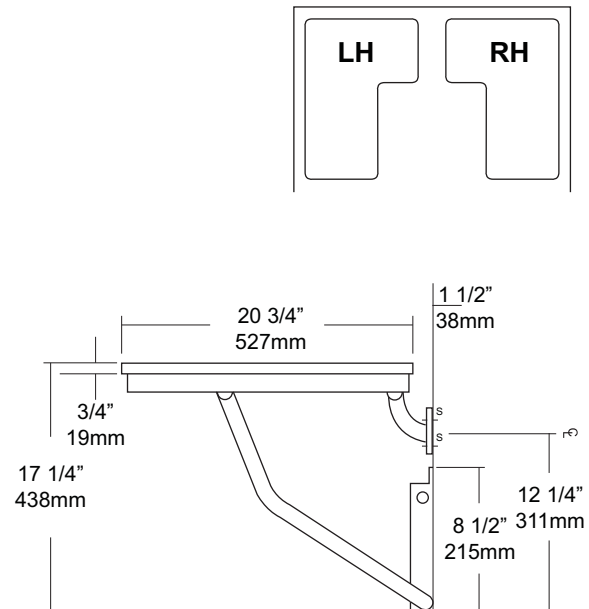
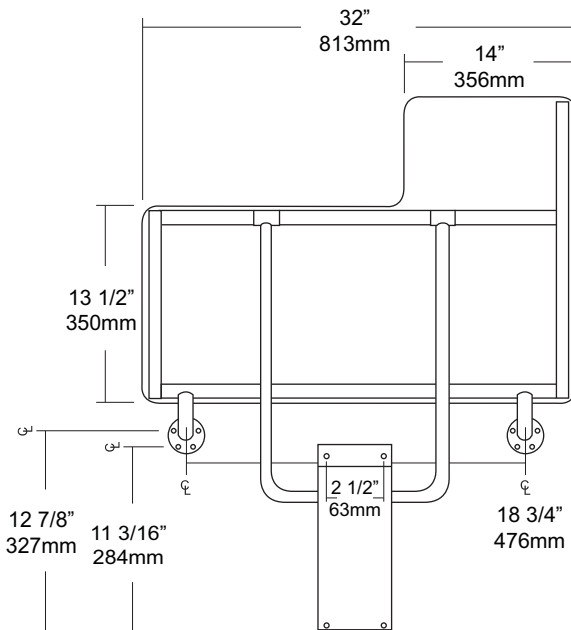

SPECIFICATIONS

- Seat:** Fabricated of 3/4" thick, one piece polymers (white) with all leading edges having a radius to prevent injury. Seat is secured to frame with carriage bolts and acorn nuts. Seat is reversible and handing is not required
- Tubing:** Fabricated of #18 ga stainless steel with #4 satin finish.
- Main Frame:** 1 1/4" diameter square tubing with capped ends.
- Flanges:** #18 gauge stainless steel with exposed mounting points. Under slung supports have a 1 1/4" OD
- Supports:** #18 ga stainless steel 1 1/4" dia diagonal stainless steel support guides for raising and lowering of seat.
- Mounting Bracket:** #18 gauge stainless steel "hat" style bracket with four (4) mounting points. Bracket acts as a guide for raising and lowering of seat. For maximum support, bracket is mounted resting on floor absorbing load transfer. Seat will remain in an upright position when not in use by means of a spring clip. Seat has been tested to maintain a 500 lb static load.
- Overall Size:** 32"W x 20 3/4"D (seating area)
813mm x 514mm
- *Wall to floor mounting design provides equal distribution of weight to ensure safe operation.**

INSTALLATION

To comply with ADA Code, seat should be mounted at a height between 17" - 19" above finished floor. Check all state and local codes for building requirements.. Recommend in wall mounting on all shower seats. (BP10) Place seat up against wall making sure the extended part of seat has an offset no more than 1 1/2" away from wall. (Same as grab bar) Transfer mounting points to wall surface and drill pilot holes. Secure seat to surface with proper fasteners for each application. Snugly secure seat to surface and check seat to be level. If seat is level raise and lower seat to check path of travel. Finish securing seat after checking seat for proper operation. When properly mounted seat will support up to 500 lbs and will conform with ADA Code 4.21.3 and 4.26.3. To change handing, remove carriage bolts, switch square length tubing to opposite side and flip deck to change handing and secure with carriage bolts to framing.

Note: This shower seat is not intended to be installed in applications that have shower bases with rounded corners. AJW recommends the U928 for such applications.

NOTES



U933

Retractable Shower Seat

Revision 1/14

JOB #:

ITEM #:

QUANTITY:

MOUNTING	HANDING	TYPE	SIZE	OTHER

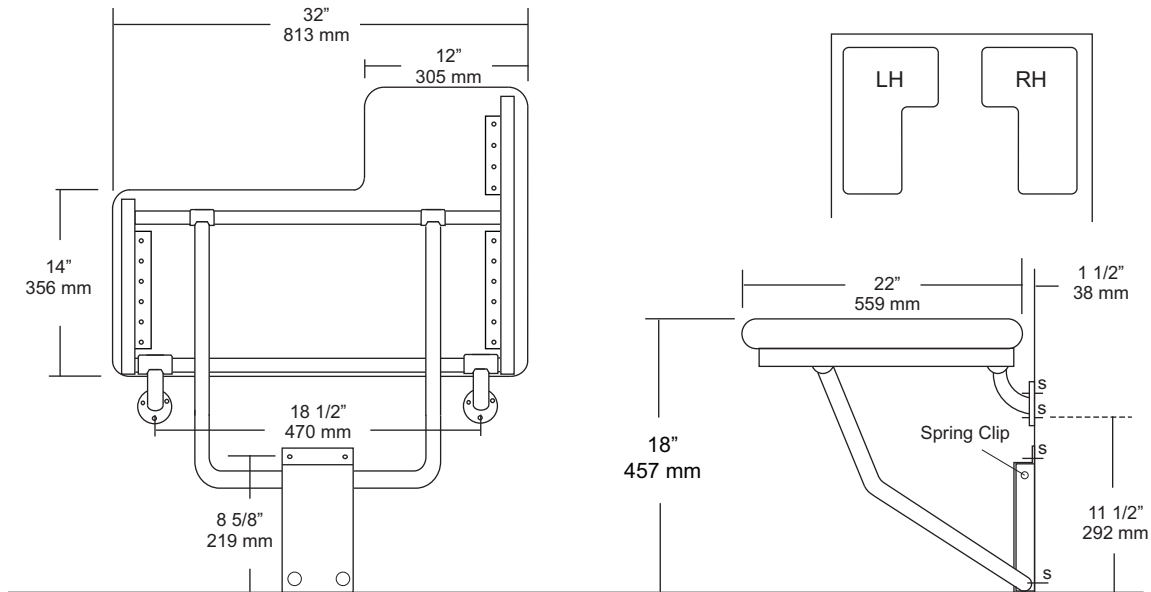

SPECIFICATIONS

Seat: Fabricated of 2 1/2" thick, water-resistant reinforced vinyl fabric cushion (white) seamless design with all leading edges having a radius. Seat is secured to a 1/2" thick marine plywood.

Tubing: Fabricated of #11 ga stainless steel with #4 satin finish.

Main Frame: #18 ga 1 1/4" with satin finish tubing. Underside has no exposed fasteners.

Flanges: #11 gauge stainless steel with four (4) exposed mounting points. Under slung supports have a 1 1/4" OD. (Satin finish)

Mounting Bracket: #16 ga stainless steel "hat" style bracket with 4 mounting support points. Bracket acts as a guide to raise and lower seat platform and is equipped with four (4) points to secure to wall surface. For maximum support, bracket is mounted so the bottom is set on the finished floor surface. Seat will remain in an upright position when not in use by means of a spring clip.

Overall Size: 32"W x 22"D (seating area)
813mm x 559mm
U933L: Left Handed
U933R: Right Handed

INSTALLATION

To comply with ADA Code, seat should be mounted at a height 17" - 19" above finished floor. Check all state and local codes for proper mounting requirements. Recommend in wall mounting on all shower seats. (BP10) Place seat up against wall making sure the extended part of seat has an offset no more than 1 1/2" away from wall. (Same as grab bar) Transfer mounting points to wall surface and drill pilot holes. Secure seat to surface with proper fasteners per each application. Snugly secure seat to surface and check seat to be level. If seat is level raise and lower seat to check path of travel. Finish securing seat after checking seat for proper operation. When properly mounted seat will support up to 250 lbs and will conform with ADA Code 4.21.3 and 4.26.3

Note: This shower seat is not intended to be installed in applications that have shower bases with rounded corners. AJW recommends the U928 for such applications.

NOTES

Formerly Model #: U933-1A