

date  
projectname  
attn  
from  
fax  
email  
phone

4/24  
Lot C  
krystal

JOB #:

ITEM #:

QUANTITY:

MOUNTING	HANDING	TYPE	SIZE	OTHER
----------	---------	------	------	-------

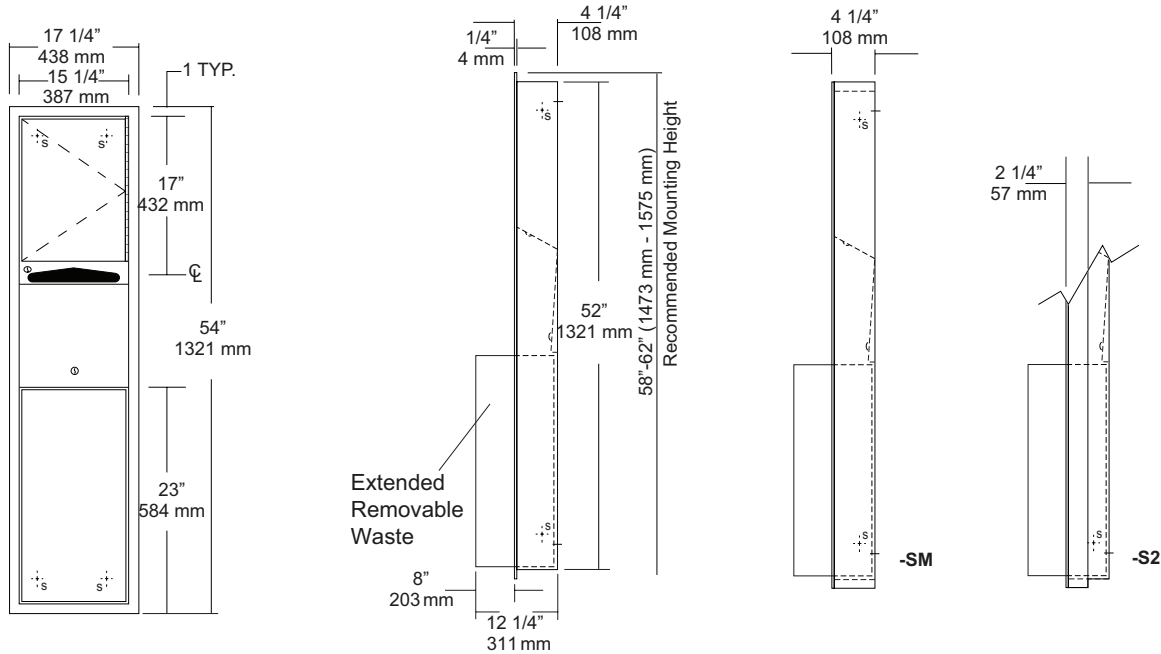

### SPECIFICATIONS

**Body:** Fabricated of #22 ga stainless steel with a #4 satin finish.

**Flange:** Fabricated of #22 ga stainless steel finished to match cabinet with 1/4" returns. (No miters or welds)

**Cabinet Back:** Fabricated of stainless steel formed for rigidity with multiple welds to cabinet body.

**Cabinet Door:** Fabricated of #22 ga stainless steel with #4 satin finish.

**Towel Dispenser:** Fabricated of #22 ga stainless steel with hemmed edges to prevent injury and towel tearing.

**Removable Waste:** Fabricated of #22 ga stainless steel #4 satin finish with all leading edges to have a radius. Unit is secured in place by a bottom bracket guide and top lock.

**Hinge:** Full length, heavy duty, stainless steel piano type hinge.

**Locks:** Pin tumbler commercial quality, keyed like all other AJW cabinets.

**Collars:** Fabricated of #22 ga stainless steel, finished to match cabinet. (Used when full recessing cannot be accomplished)

**Overall Size:** 17 1/4"W x 54"H x 12 1/4"D (wall depth req)  
**438mm x 1372mm x 108mm**

**Wall Opening:** 15 3/4"W x 52 1/2"H x 4"D  
**400mm x 1334mm**

**U651-S2:** semi-recessed. with 2" collar, 2" wall opening 50mm

**U651-SM:** Surface mounted

**Towel Capacity:** 600 c-fold or 800 multifold

**Waste Capacity:** 18 gallons (3.34 cu ft)

### INSTALLATION

Coordinate installation with architect and contractor to avoid interference with pipes, vents, etc. Provide a rough wall opening 15 3/4"W x 52 1/2"H. See chart for required wall depth. If collar is required, slide collar over the back before installing into wall. Remove waste from cabinet and mount unit plumb and true in opening with proper fasteners per application. Secure waste in cabinet and load paper towels.

When cleaning cabinet use a non abrasive non-chloric solution and wiped off with the grain of the cabinet.

### NOTES



# U864

## Waste Disposal & Toilet Tissue Dispenser Combination Unit

Revision 05/11

JOB #:
ITEM #:
QUANTITY:

MOUNTING	HANDING	TYPE	SIZE	OTHER

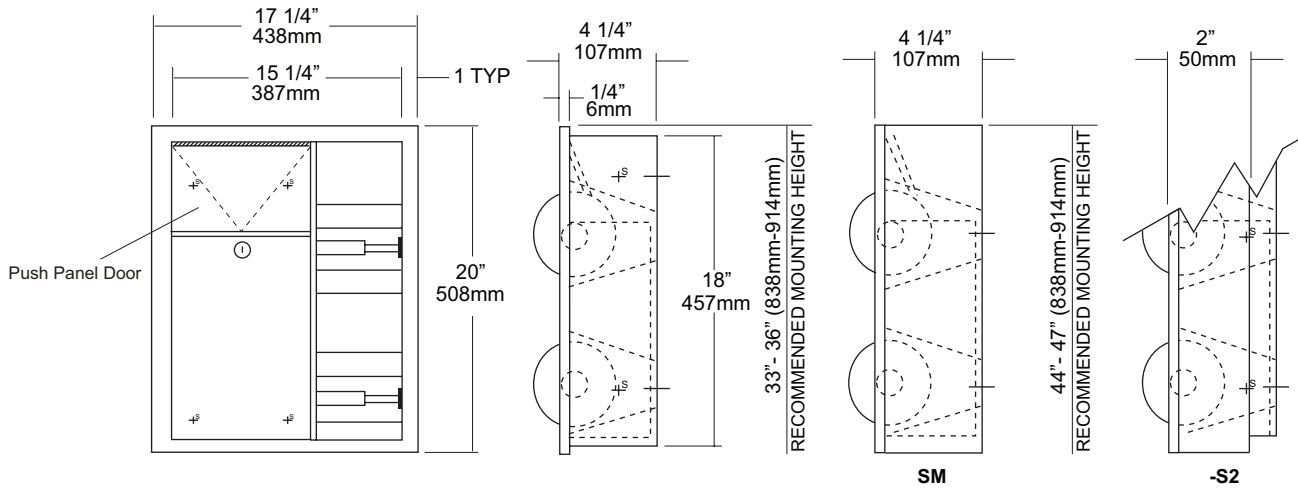

### SPECIFICATIONS

**Cabinet:** Fabricated of #22 gauge stainless steel. All exposed surfaces have a #4 satin finish.

**Flange:** Fabricated of #22 gauge stainless steel one-piece drawn seamless construction. No seams or exposed miters with 1/4" returns to wall surface.

**Napkin Disposal:** Self closing push panel door is fabricated of #22 gauge stainless steel. Removable Waste is fabricated of same material with pin tumbler lock. Waste is identified with International Graphic symbol.

**Toilet Tissue Dispenser:** #22 gauge stainless steel hat adapters secure chrome plated, spring loaded rollers in place.

**U007 Theft Resistant Adapters:** Optional style rollers that prevent core from being removed until roll has been depleted.

**Hinges:** All hinges are full length, heavy duty, stainless steel piano type hinges.

**Collars:** #22 ga stainless steel finished to match cabinet.

**Overall Size:** 17 1/4"W x 20"H x 4 1/4"D  
438mm x 508mm x 108mm

**Wall Opening:** 15 3/4"W x 18 1/2"H x 4"D  
400mm x 470mm x 102mm

**U864-S2:** 2" semi-recessed. collar, 2" wall opening, 51 mm

**U864-SM:** Full surface mounted collar.

**Waste Capacity:** 2 Gallons (.26 cu ft)

**Toilet Tissue:** Two standard rolls with a 5 1/4" (133mm) OD.

### INSTALLATION

Provide rough wall opening at desired or specified location of 15 3/4"W x 18 1/2"H. (Depth of opening will depend on type mounting required.) Place lower unit in opening to ensure proper fit. If unit fits properly in opening, secure with proper fasteners per application.. If collars are required, place collar onto the units from the back before securing to mounting area. Fill toilet tissue rolls.

Toilet Paper Dispensers: All dispensers that are to meet ADA code cannot have any type of controlled delivery. (4.16)

### NOTES



**U865**  
Waste Disposal & Toilet Tissue Dispenser  
Combination Unit

Revision 03/11

JOB #:

ITEM #:

QUANTITY:

MOUNTING	HANDING	TYPE	SIZE	OTHER

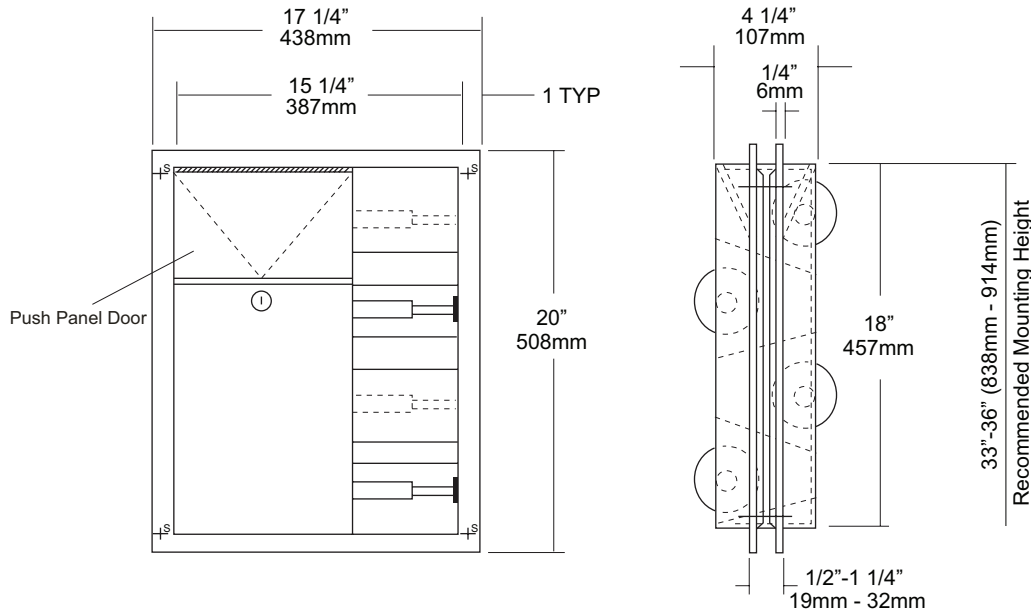

**SPECIFICATIONS**

**Cabinet:** Fabricated of #22 gauge stainless steel. All exposed surfaces have a #4 satin finish.

**Adj. Flanges:** Fabricated of #22 gauge stainless steel one-piece drawn seamless construction. No seams or exposed miters with 1/4" returns to wall surface. (Exposed mounting points)

**Toilet Tissue Dispenser:** #22 gauge stainless steel hat adapters secure chrome plated, spring loaded rollers in place.

**U007 Theft Resistant Adapter:** Prevents spindle from being removed until roll has been depleted.

**Hinges:** All hinges are full length, heavy duty, stainless steel piano type hinges.

**Overall Size:** 17 1/4"W x 20"H x 4 1/4"D  
438mm x 508mm x 108mm

**Adjustable to fit partitions 1/2"- 1 1/4" thick.**

**Wall Opening:** 15 3/4"W x 18 1/2"H  
400mm x 470mm

**Toilet Tissue Capacity:** Four standard rolls with a 5 1/4" (133mm) OD.

**Waste Capacity:** 2 Gallons (.26 cu ft)

**INSTALLATION**

Provide rough wall opening at desired or specified location of 15 3/4"W x 18 1/2"H. Place lower unit in opening to ensure proper fit. If unit fits properly in opening, secure side with the fixed flange at exposed mounting points. Secure adjustable flange last in the same manor. Secure with proper fasteners per each application. Fill toilet tissue rolls.

Toilet Paper Dispensers: All dispensers that are to meet ADA code cannot have any type of controlled delivery. (4.16)

**NOTES**



# U933

## Retractable Shower Seat

Revision 1/14

JOB #:

ITEM #:

QUANTITY:

MOUNTING	HANDING	TYPE	SIZE	OTHER

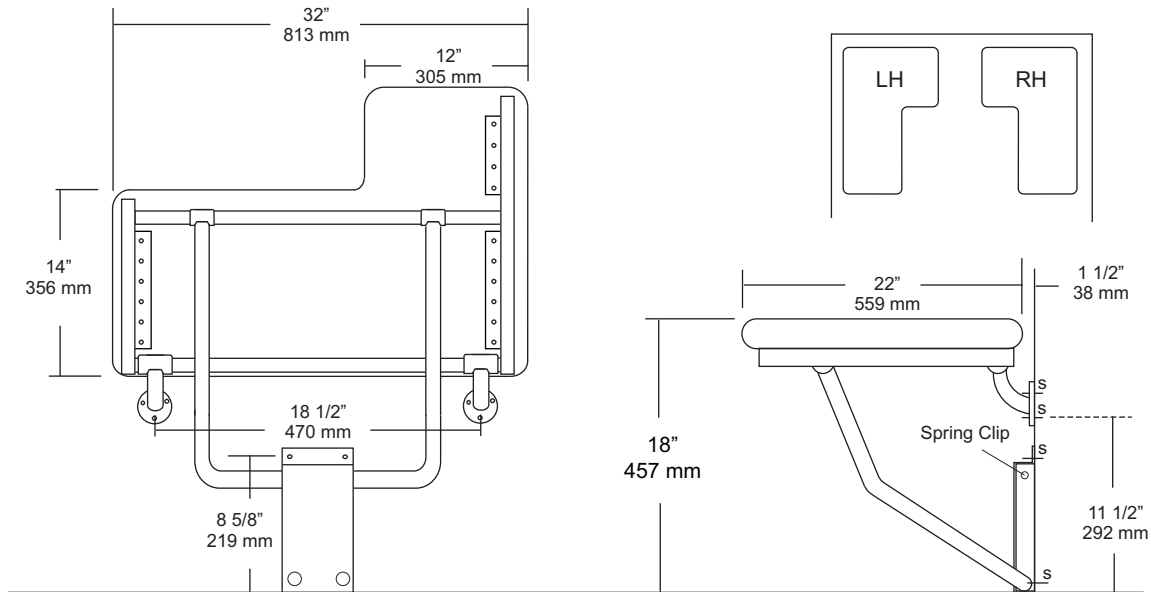

### SPECIFICATIONS

**Seat:** Fabricated of 2 1/2" thick, water-resistant reinforced vinyl fabric cushion (white) seamless design with all leading edges having a radius. Seat is secured to a 1/2" thick marine plywood.

**Tubing:** Fabricated of #11 ga stainless steel with #4 satin finish.

**Main Frame:** #18 ga 1 1/4" with satin finish tubing. Underside has no exposed fasteners.

**Flanges:** #11 gauge stainless steel with four (4) exposed mounting points. Under slung supports have a 1 1/4" OD. (Satin finish)

**Mounting Bracket:** #16 ga stainless steel "hat" style bracket with 4 mounting support points. Bracket acts as a guide to raise and lower seat platform and is equipped with four (4) points to secure to wall surface. For maximum support, bracket is mounted so the bottom is set on the finished floor surface. Seat will remain in an upright position when not in use by means of a spring clip.

**Overall Size:** 32"W x 22"D (seating area)  
**813mm x 559mm**  
**U933L:** Left Handed  
**U933R:** Right Handed

### INSTALLATION

To comply with ADA Code, seat should be mounted at a height 17" - 19" above finished floor. Check all state and local codes for proper mounting requirements. Recommend in wall mounting on all shower seats. (BP10) Place seat up against wall making sure the extended part of seat has an offset no more than 1 1/2" away from wall. (Same as grab bar) Transfer mounting points to wall surface and drill pilot holes. Secure seat to surface with proper fasteners per each application. Snugly secure seat to surface and check seat to be level. If seat is level raise and lower seat to check path of travel. Finish securing seat after checking seat for proper operation. When properly mounted seat will support up to 250 lbs and will conform with ADA Code 4.21.3 and 4.26.3

Note: This shower seat is not intended to be installed in applications that have shower bases with rounded corners. AJW recommends the U928 for such applications.

### NOTES

Formerly Model #: U933-1A



# UG3-A

Grab Bars

Revised 03/11

JOB #:

ITEM #:

QUANTITY:

MOUNTING	HANDING	TYPE	SIZE	OTHER



## SPECIFICATIONS & INSTALLATION

**Tubing:** Fabricated of #18 ga stainless steel with a #4 satin finish. Available in 1 1/2" outside diameter. All bends are formed by an automatic mandrel bending process. All bars maintain a constant 1 1/2" offset.

**Finish:** Standard finish is a #4 satin finish. For a non-slip finish (peened) add suffix X to model number. (Ex. UG3X-A)

**Flanges:** Snap flanges are fabricated of 3" diameter, 3/8" deep drawn #22 ga stainless steel with #4 satin finish to match tubing. Flanges have dimples that secure over mounting plate.

**Strength:** Bars with a 1 1/2" offset clearance will support loads in excess of 900lbs when properly installed. Bars with greater offsets will support loads up to 250lbs when properly installed.

**Installation:** Before installing grab bars, verify with all state and local codes for requirements on bar diameter and type finish. Recommended mounting heights for grab bars are 33" - 36" centerline above finished floor. All mounting of grab bars when possible should have in wall mounting back plates. Find centerline mounting points and place bar on line making sure to be on center. Transfer mounting points (3 per flange) to wall. Drill pilot holes and secure bar with proper anchors per application. Snap cover over mounting plate.

**Standard Lengths (Other sizes available upon request):** 12", 16", 18", 24", 30", 32", 36", 42", 48", 50", 52", 54", 56"

## FLANGE INFORMATION

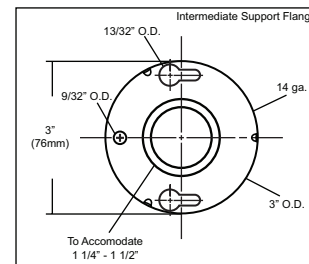
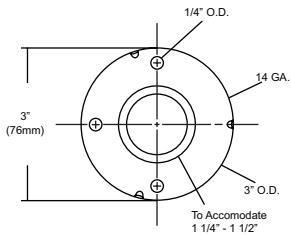
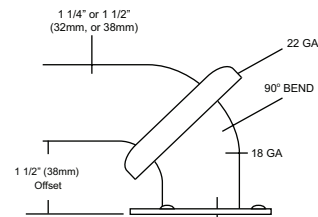

## NOTES



# UX116-BF

Heavy Duty Coat Hook

Revision 03/11

JOB #:

ITEM #:

QUANTITY:

MOUNTING	HANDING	TYPE	SIZE	OTHER

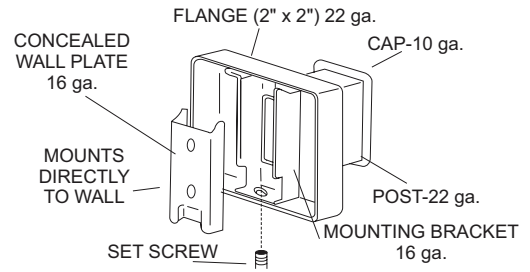
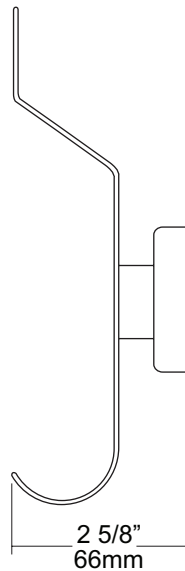
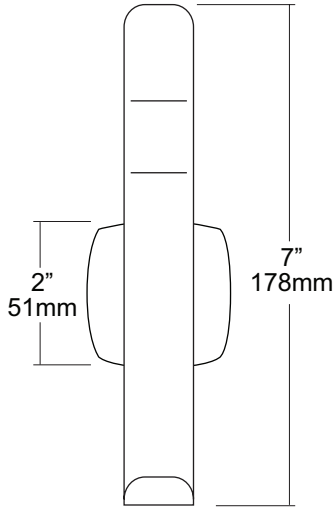

### SPECIFICATIONS

**UX Accessories:** All UX bath accessories series are fabricated of stainless steel with a bright or satin finish. Mounting plates are concealed with a snap-on type plate secured by a set screw.

**Hook:** #10 ga stainless steel hook.

**Flange:** 2" x 2" flange #22 ga stainless steel.

**Post:** #22 ga stainless steel.

**Mounting Plate:** #16 ga stainless steel concealed wall plate. Set screw secures mounting plate and flange.

**Overall Size:** 2"W x 7"H x 2 5/8"D

**51mm x 178mm x 66mm**

**UX116-SF:** Same as UX116-BF with satin finish.

### INSTALLATION

Provide an area on wall surface at desired or specified location. Place concealed mounting plate on wall surface and transfer mounting points. Drill pilot holes and secure with proper fasteners. Place snap on flange over plate and secure with set screw.

### NOTES