



**U473**  
Waste Receptacle Swing Top

Revision 03/11

JOB #:

ITEM #:

QUANTITY:

MOUNTING	HANDING	TYPE	SIZE	OTHER

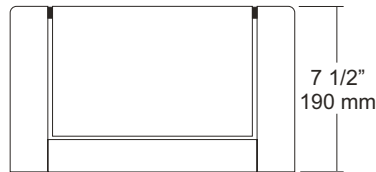
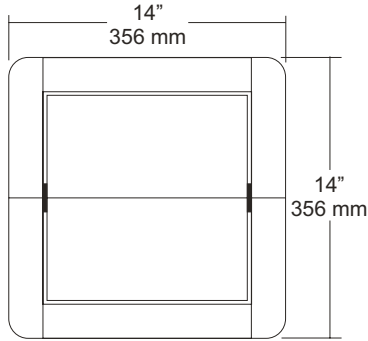

PUSH DOOR SWINGS BOTH WAYS

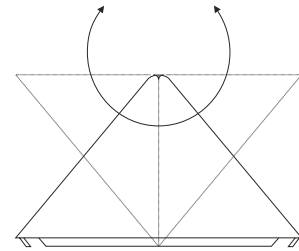

**SPECIFICATIONS**

**Swing Top:** Fabricated of #20 gauge stainless steel with a #4 satin finish fully welded construction. Door swings freely in both directions. All edges are hemmed to prevent injury. Unit will fit U470-13 & U470-25 free standing waste.

**Overall Size:** 14"W x 7 1/2"H x 14"D  
356mm x 191mm x 356mm

**INSTALLATION**

Swing top will rest on top of the rubber wall bumpers on the U470-13 & U470-25 free standing waste receptacles.

**NOTES**