

date
projectname
attn
from
fax
email
phone

9/30/2019
Glenstone
Jade
Jade
projectmgt@southeasthospitality.net
8645033725



U659AW

Roll Towel & Waste Combination Unit

Revision 10/14

JOB #:

ITEM #:

QUANTITY:

MOUNTING	HANDING	TYPE	SIZE	OTHER
----------	---------	------	------	-------

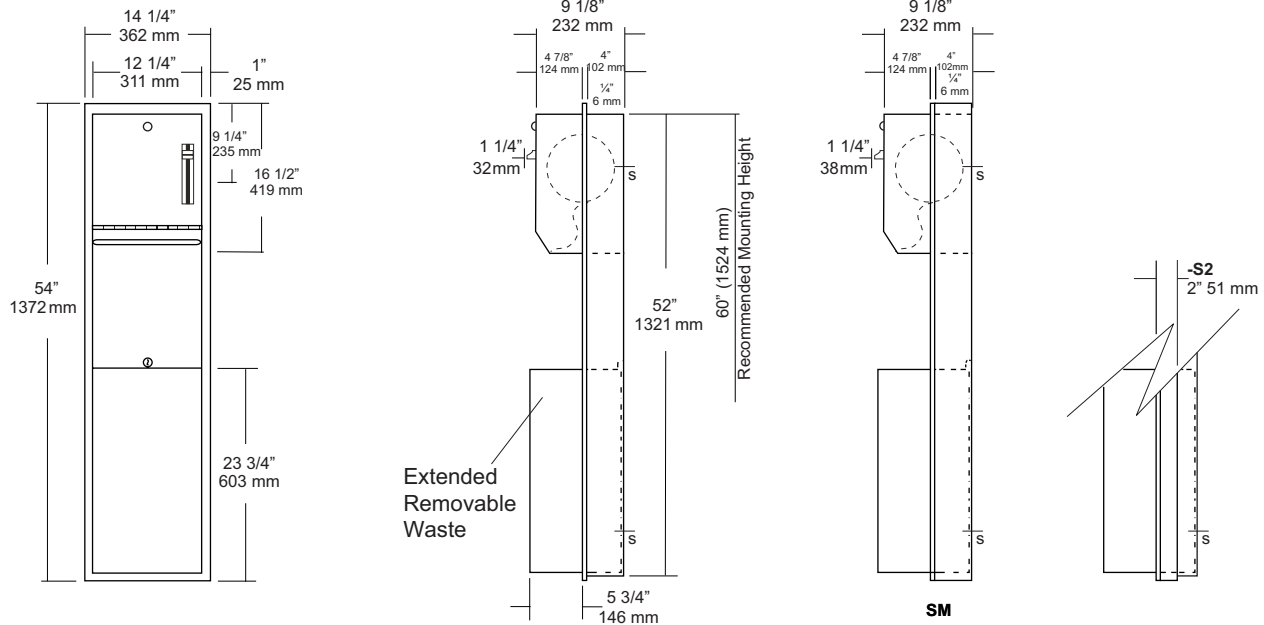

SPECIFICATIONS

Body: Fabricated of #22 ga stainless steel with a #4 satin finish.

Flange: Fabricated of #22 ga stainless steel finished to match cabinet with 1/4" returns. (No miters or welds)

Cabinet Back: Fabricated of stainless steel formed for rigidity with multiple welds to cabinet body.

Cabinet Door: Fabricated of #18 ga stainless steel with #4 satin finish, with full length door stop to reduce vandalism

Towel Dispenser: Roll towel mechanism is fabricated of #20 ga steel formed for rigidity. Unit will accommodate one 8" or 9" wide roll with a max O.D. of 7 7/8". Towel length dispensed has three adjustable settings. Lever is activated with one hand and less than 5 lbs of force to activate.

Removable Extended Waste: Fabricated of #22 ga stainless steel #4 satin finish with all leading edges to have a radius. Unit is secured in place by a bottom bracket guide and top lock. Embossed tabs allow liners to be held in place.

Hinge: Full length, heavy duty, stainless steel piano type hinge.

Collars: Fabricated of #22 ga stainless steel, finished to match cabinet. (semi-recessed and surface mounted)

Overall Size: 14 1/4"W x 54"H x 10"D
362mm x 1372mm x 254mm

Wall Opening: 12 3/4"W x 52 1/2"H x 4"D
324mm x 1334mm x 102mm

U659-S2: 2" semi-recessed. collar, 2" wall opening, 51mm

U659-SM: Full surface mounted collar.

Towel Capacity: One standard size roll of 8" or 9" wide. (Use only non-perforated towels). One stub roll up to 2 3/4" OD

Waste Capacity: 12 gallons (1.60 cu ft)

***Recommend 600ft roll for best results.**

Options:

-VL1: Reusable vinyl liner

INSTALLATION

Coordinate installation with architect and contractor to avoid interference with pipes, vents, etc. Provide a rough wall opening 12 3/4"W x 52 1/2"H. Required wall depth, will depend if full or semi-recessing is required. If collar is required, slide collar over the back before installing into wall. Remove waste from cabinet and mount unit plumb and true in opening with proper fasteners per application. Secure waste in cabinet and load paper towels.

Controls and or mechanisms should operate with one hand and force required to activate controls shall be no greater than 5 lbs. (4.27.4)

NOTES



U842

Toilet Tissue Dispenser

Revision 03/11

JOB #:

ITEM #:

QUANTITY:

MOUNTING	HANDING	TYPE	SIZE	OTHER

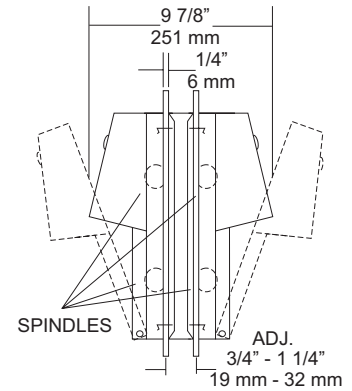
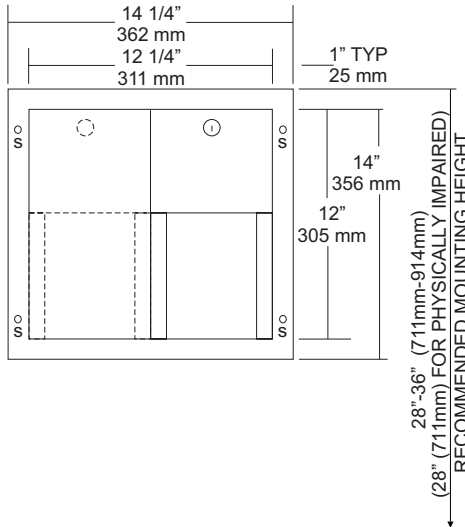
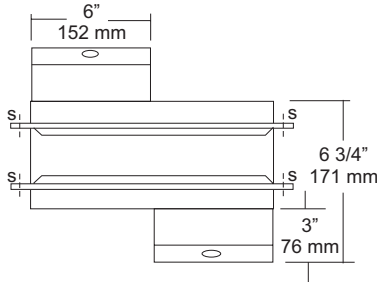

SPECIFICATIONS

- Body:** Fabricated of #22 ga stainless steel with #4 satin finish. Concealed inner dispensing mechanism is #18 ga stainless steel.
- Back:** Fabricated of #18 ga stainless steel with multiple welds to cabinet body forming a one piece construction.
- Hoods:** Fabricated of #18 ga stainless steel finished to match cabinet body. Hood is secured with stainless steel hinge rivets to cabinet body. Top roll of tissue will not drop down unless the bottom roll has been depleted. When unit is closed, this will provide a theft resistant, non-control operation and reduce vandalism.
- Flanges:** One piece construction without miters or welds fabricated of #22 ga stainless steel, #4 satin finish. Adjustable to fit 3/4" - 1 1/4" thick partitions.
- Locks:** Pin tumbler, commercial quality locks keyed like all other AJW cabinets.
- Spindles:** (U005) Fabricated of one-piece molded high impact black ABS material.
- Overall Size:** 14 1/4"W x 14"H x 9 7/8"D
362mm x 356mm x 251mm
- Wall Opening:** 12 1/2"W x 12 1/4"H
318mm x 311mm
- Capacity:** Four standard rolls with a 5 1/4" (133mm) OD.

INSTALLATION

Coordinate installation with architect or contractor. Provide a rough wall opening in mounting surface at desired or specified location making sure unit will be level. Open cabinet, remove spindles and adjustable flange. Insert into opening and secure unit with proper fasteners per each application. Secure adjustable flange with proper fasteners. Load toilet tissue on rollers, place in concealed track and close hood. Raise lower roll against upper and take hand away. Lower roll should fall into place with upper roll remaining up above the hood line. If loaded properly, top roll will not fall for use until bottom roll has been depleted. Follow same procedure for both sides. When servicing dispenser, full rolls must be used on both spindles to insure proper operation.

Toilet Paper Dispensers: All dispensers that are to meet ADA code cannot have any type of controlled delivery. (4.16)

NOTES

Formerly Model #: U842A



UG120-A

Grab Bars

Revised 03/11

JOB #:

ITEM #:

QUANTITY:

MOUNTING	HANDING	TYPE	SIZE	OTHER

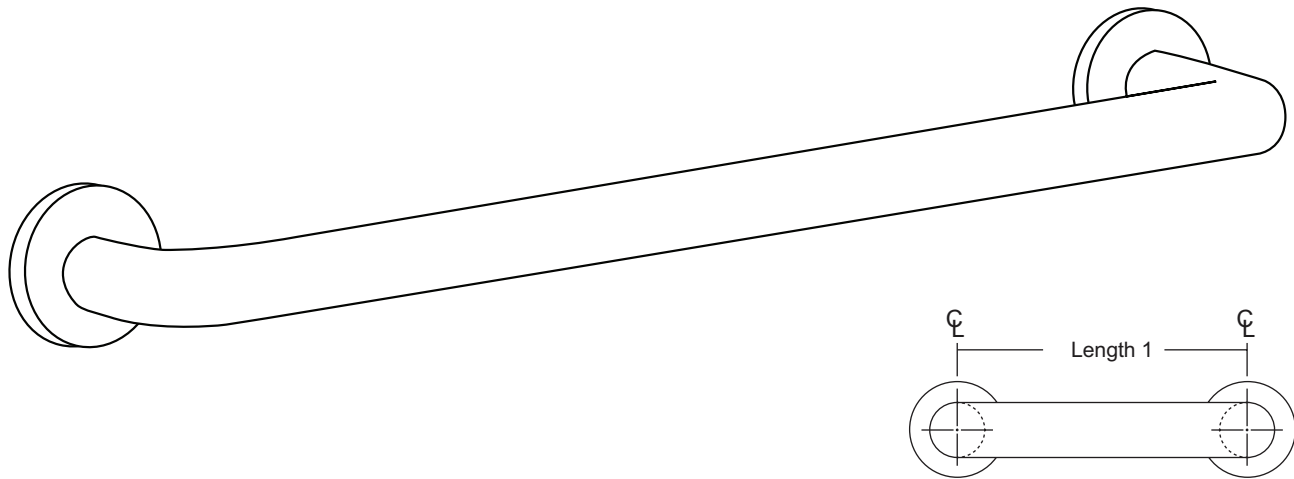

SPECIFICATIONS & INSTALLATION FLANGE INFORMATION

Tubing: Fabricated of #18 ga stainless steel with a #4 satin finish. Available in 1 1/4" outside diameter. All bends are formed by an automatic mandrel bending process. All bars maintain a constant 1 1/2" offset.

Finish: Standard finish is a #4 satin finish. For a non-slip finish (peened) add suffix X to model number. (Ex. UG120X-A)

Flange: Fabricated of 3" diameter, #11 ga stainless steel with #4 satin finish to match tubing. Flanges are heliarc welded to bar to form a one piece construction. Each flange has three (3) mounting points (1/4" dia.)

Strength: Bars with a 1 1/2" offset clearance will support loads in excess of 900lbs when properly installed. Bars with greater offsets will support loads up to 250lbs when properly installed.

Installation: Before installing grab bars, verify with all state and local codes for requirements on bar diameter and type finish. Recommended mounting heights for grab bars are 33" - 36" centerline above finished floor. All mounting of grab bars when possible should have in wall mounting back plates. Find centerline mounting points and place bar on line making sure to be on center. Transfer mounting points (3 per flange) to wall. Drill pilot holes and secure bar with proper anchors per application.

Standard Lengths (Other sizes available upon request): 12", 16", 18", 24", 30", 32", 36", 42", 48", 50", 52", 54", 56"

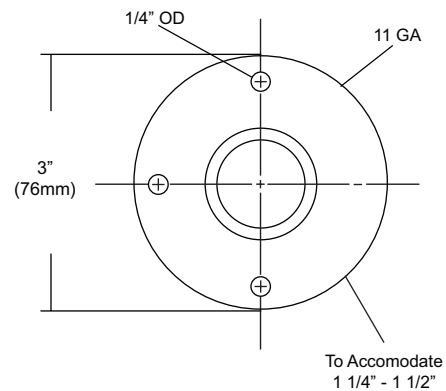
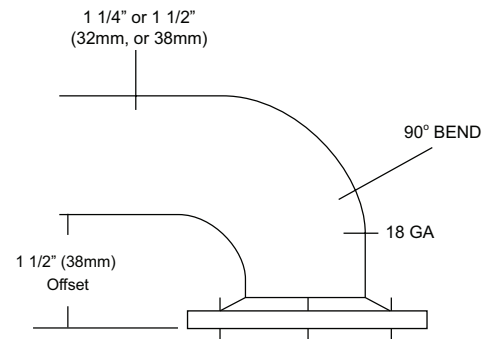

NOTES