

date
projectname
attn
from
fax
email
phone

1/1/12
d
g



U582
Surface Mounted Sanitary Napkin
Disposal

Revision 03/11

JOB #:

ITEM #:

QUANTITY:

MOUNTING	HANDING	TYPE	SIZE	OTHER

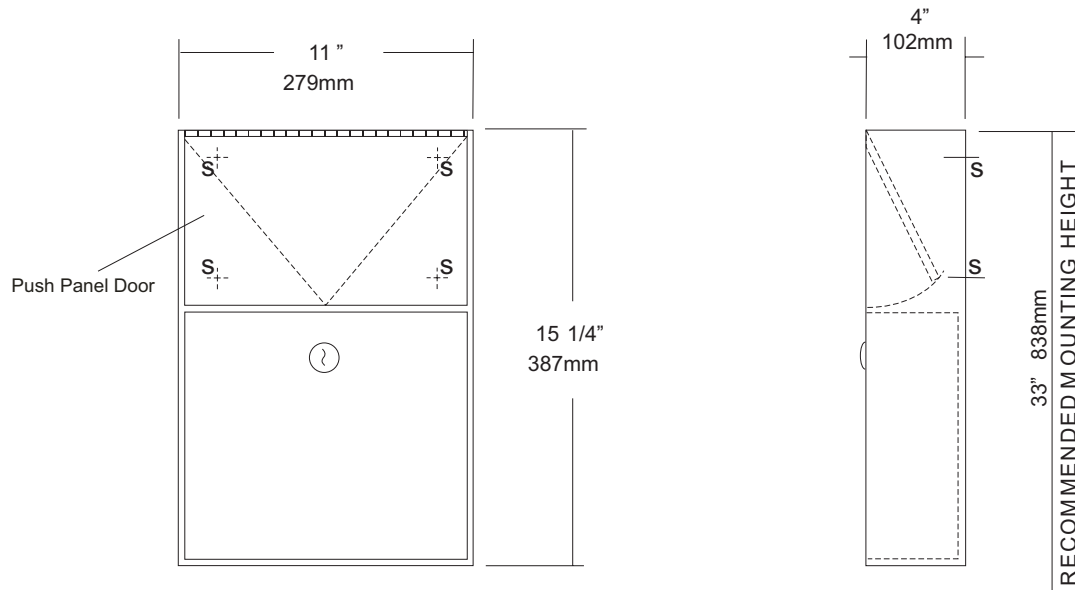

SPECIFICATIONS

Cabinet Body: Fabricated of #22 ga stainless steel #4 satin finish,
Push Panel: Fabricated of #22 ga stainless steel self closing push panel. International graphic symbols are optional.
Waste: #22 ga stainless steel removable type waste secured by a pin tumbler lock. Optional finger grip in lieu of lock is available.
Locks: Pin tumbler commercial quality locks keyed like all other AJW cabinets,
Hinge: Full length, heavy duty, stainless steel piano type hinge,
Overall Size: 11"W x 15 1/4"H x 4"D
279mm x 387mm x 102mm
Capacity: 1.5 gallons (.2 cu ft.)
NDL-13-50: Waxed disposable liners. (50 per Case)
OPTIONS:
-PW: Rigid plastic waste insert
-IGS: International Graphic Symbol

INSTALLATION

Provide an area on wall surface at desired or specified location. Place unit on wall and verify unit is level. Transfer mounting point locations and drill pilot holes. Remove waste can and secure to wall surface with proper fasteners for each application.

NOTES



U704 Series

Fixed Tilt Angle Frame Mirror

Revision 11/15

JOB #:

ITEM #:

QUANTITY:

MOUNTING	HANDING	TYPE	SIZE	OTHER

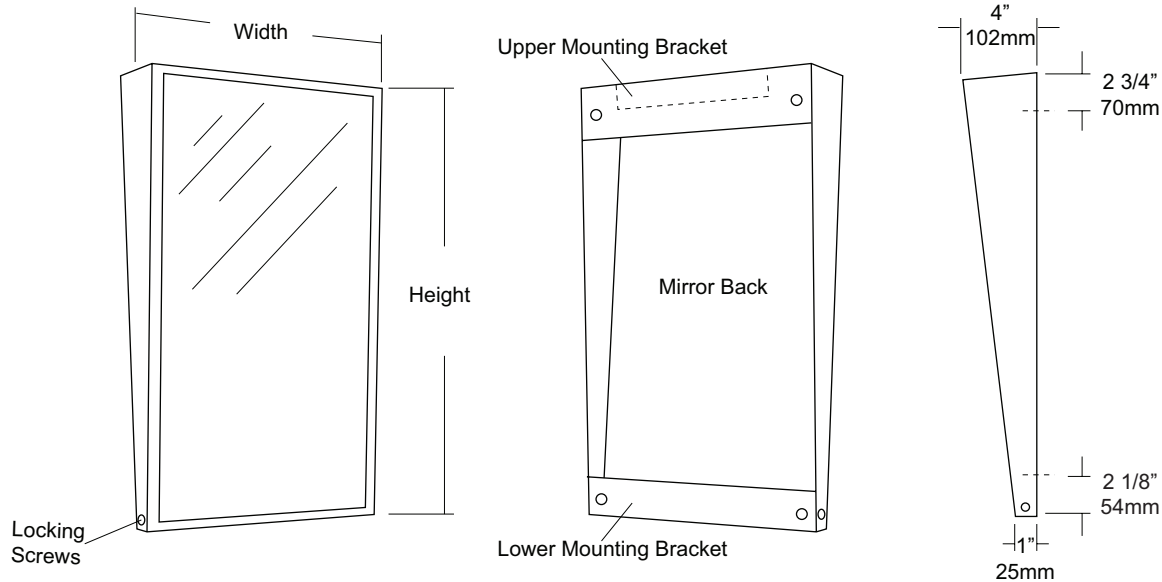

SPECIFICATIONS

Frame: Fabricated of #18 ga stainless steel, #4 satin finish. Stainless steel frame is fabricated with welded mitered corners that are ground and polished smooth. Mirror extends out 4" at top and tapers to 1" at bottom.

Mirror: 1/4" thick type 1 transparent flat type, class 1 - clear glass mirrors. Mirror is coated with silver and sealed with a uniform electrolytic copper plating, along with two coats of paint for added protection. Mirrors are guaranteed against silver spoilage for a period of 15 years. Mirrors conform to ASTM C1036 and ASTM C1503-R8.

Filler: 3/16" thick full size, shock absorbing, water resistant, non-abrasive polyethylene padding protects all concealed mirror surfaces

Brackets: Mounting brackets are fabricated of #20 ga pre-plated, galvanized steel. Lower bracket has two (2) side mounting points that allow frame to be secured to bracket.

Standard Sizes Available (W x H): 16"x24", 16"x30", 18"x24", 18"x30", 18"x36", 24"x30", 24"x36"

Options:

LG: Laminated Glass

LX: Polycarbonate

PM: Plastic Acrylic

T: Tempered Glass

VC: Vinyl Clad (Safety Glass)

8B: #8 Reflective Stainless Steel

*Stainless steel mirrors reflect images in different optic quality than plate glass. There will be a slight distortion which increases proportionately with the mirror size. Therefore, AJW Architectural Products™ cannot be held responsible for quality of image.

** Mirrors are always ordered Width x Height

*** Recommended max size for 8B mirrors: 72" x 47-1/2"

**** Framed mirrors are fabricated to a tolerance of (+/-) 1/8"

***** Mirrors conform to Federal Specifications DD-M-00411b & DD-g-541D

INSTALLATION

Coordinate installation with architect / contractor for specific mounting location and height for each mirror application. Check all state and local codes for installation requirements. Remove hanger brackets and transfer mounting points to wall surface. Secure with proper fasteners for each application. Slide mirror frame over brackets and secure in place. Secure frame to bracket. Fillers are available if mirrors are mounted above and below tile line. (U004 Filler) Filler material will match mirror frame to form a one piece construction.

To meet ADA Code, bottom edge of reflective surface can be no higher than 40" above finished floor. (4.19.6) Full length mirrors may be used for universal application when installed in correct locations.

Abrasive cleaners & chloric solutions should not be used on mirrors. Discoloring or scratching may occur on frame and reflective surface.

NOTES

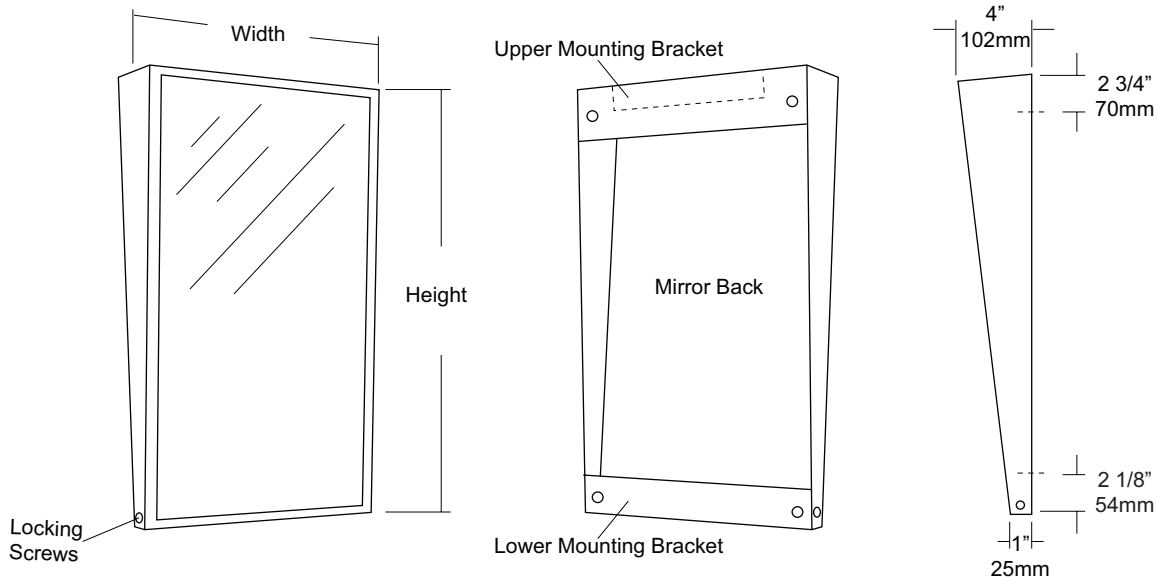

INSTALLATION

Coordinate installation with architect / contractor for specific mounting location and height for each mirror application. Check all state and local codes for installation requirements. Remove mirror back and transfer mounting points to wall surface. Secure back with proper fasteners for each application. Slide mirror down over frame and snap in place. Secure frame to back. Fillers are available if mirrors are mounted above and below tile line. (U004 Filler) Filler material will match mirror frame to form a one piece construction.

To meet ADA Code, bottom edge of reflective surface can be no higher than 40" above finished floor. (4.19.6) Full length mirrors may be used for universal application when installed in correct locations.

CARE & CLEANING

Wipe mirrors with a soft cloth, taking special care to rub stainless steel frames with the grain to avoid scratching. Do not use abrasive cleaners containing chloric solutions on stainless steel frames. Glass Plus or other window cleaning products are ideal.



U929 Retractable Shower Seat

Revision 1/14

JOB #:

ITEM #:

QUANTITY:

MOUNTING	HANDING	TYPE	SIZE	OTHER
----------	---------	------	------	-------

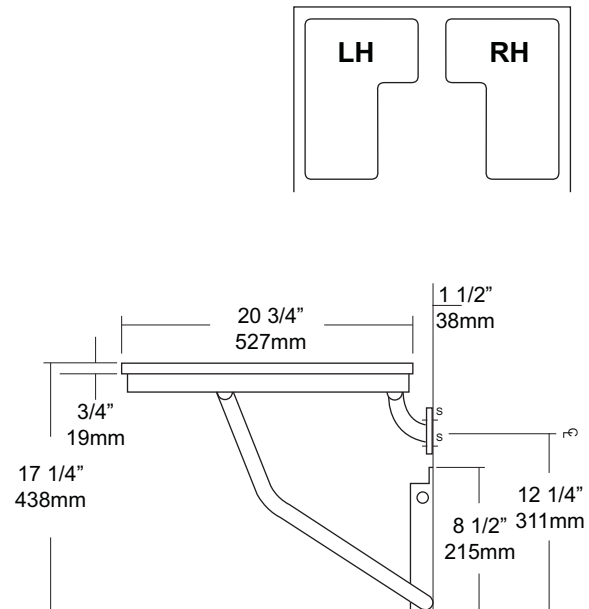
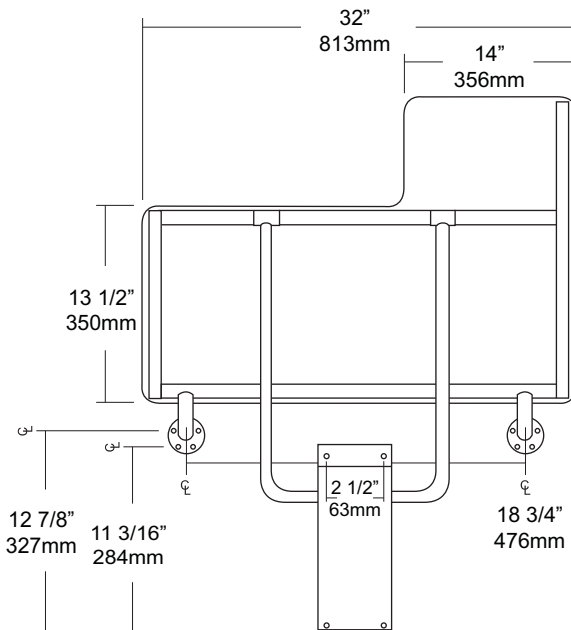

SPECIFICATIONS

- Seat:** Fabricated of 3/4" thick, one piece polymers (white) with all leading edges having a radius to prevent injury. Seat is secured to frame with carriage bolts and acorn nuts. Seat is reversible and handing is not required
- Tubing:** Fabricated of #18 ga stainless steel with #4 satin finish.
- Main Frame:** 1 1/4" diameter square tubing with capped ends.
- Flanges:** #18 gauge stainless steel with exposed mounting points. Under slung supports have a 1 1/4" OD
- Supports:** #18 ga stainless steel 1 1/4" dia diagonal stainless steel support guides for raising and lowering of seat.
- Mounting Bracket:** #18 gauge stainless steel "hat" style bracket with four (4) mounting points. Bracket acts as a guide for raising and lowering of seat. For maximum support, bracket is mounted resting on floor absorbing load transfer. Seat will remain in an upright position when not in use by means of a spring clip. Seat has been tested to maintain a 500 lb static load.
- Overall Size:** 32"W x 20 3/4"D (seating area)
813mm x 514mm
- *Wall to floor mounting design provides equal distribution of weight to ensure safe operation.**

INSTALLATION

To comply with ADA Code, seat should be mounted at a height between 17" - 19" above finished floor. Check all state and local codes for building requirements.. Recommend in wall mounting on all shower seats. (BP10) Place seat up against wall making sure the extended part of seat has an offset no more than 1 1/2" away from wall. (Same as grab bar) Transfer mounting points to wall surface and drill pilot holes. Secure seat to surface with proper fasteners for each application. Snugly secure seat to surface and check seat to be level. If seat is level raise and lower seat to check path of travel. Finish securing seat after checking seat for proper operation. When properly mounted seat will support up to 500 lbs and will conform with ADA Code 4.21.3 and 4.26.3. To change handing, remove carriage bolts, switch square length tubing to opposite side and flip deck to change handing and secure with carriage bolts to framing.

Note: This shower seat is not intended to be installed in applications that have shower bases with rounded corners. AJW recommends the U928 for such applications.

NOTES



UG3-A

Grab Bars

Revised 03/11

JOB #:

ITEM #:

QUANTITY:

MOUNTING	HANDING	TYPE	SIZE	OTHER



SPECIFICATIONS & INSTALLATION

Tubing: Fabricated of #18 ga stainless steel with a #4 satin finish. Available in 1 1/2" outside diameter. All bends are formed by an automatic mandrel bending process. All bars maintain a constant 1 1/2" offset.

Finish: Standard finish is a #4 satin finish. For a non-slip finish (peened) add suffix X to model number. (Ex. UG3X-A)

Flanges: Snap flanges are fabricated of 3" diameter, 3/8" deep drawn #22 ga stainless steel with #4 satin finish to match tubing. Flanges have dimples that secure over mounting plate.

Strength: Bars with a 1 1/2" offset clearance will support loads in excess of 900lbs when properly installed. Bars with greater offsets will support loads up to 250lbs when properly installed.

Installation: Before installing grab bars, verify with all state and local codes for requirements on bar diameter and type finish. Recommended mounting heights for grab bars are 33" - 36" centerline above finished floor. All mounting of grab bars when possible should have in wall mounting back plates. Find centerline mounting points and place bar on line making sure to be on center. Transfer mounting points (3 per flange) to wall. Drill pilot holes and secure bar with proper anchors per application. Snap cover over mounting plate.

Standard Lengths (Other sizes available upon request): 12", 16", 18", 24", 30", 32", 36", 42", 48", 50", 52", 54", 56"

FLANGE INFORMATION

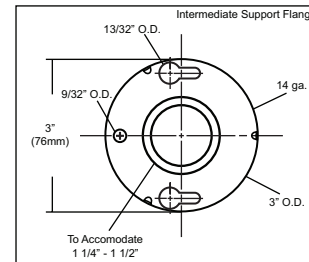
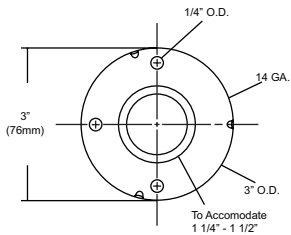

NOTES



UG3-G

Grab Bars

Revised 03/11

JOB #:

ITEM #:

QUANTITY:

MOUNTING	HANDING	TYPE	SIZE	OTHER

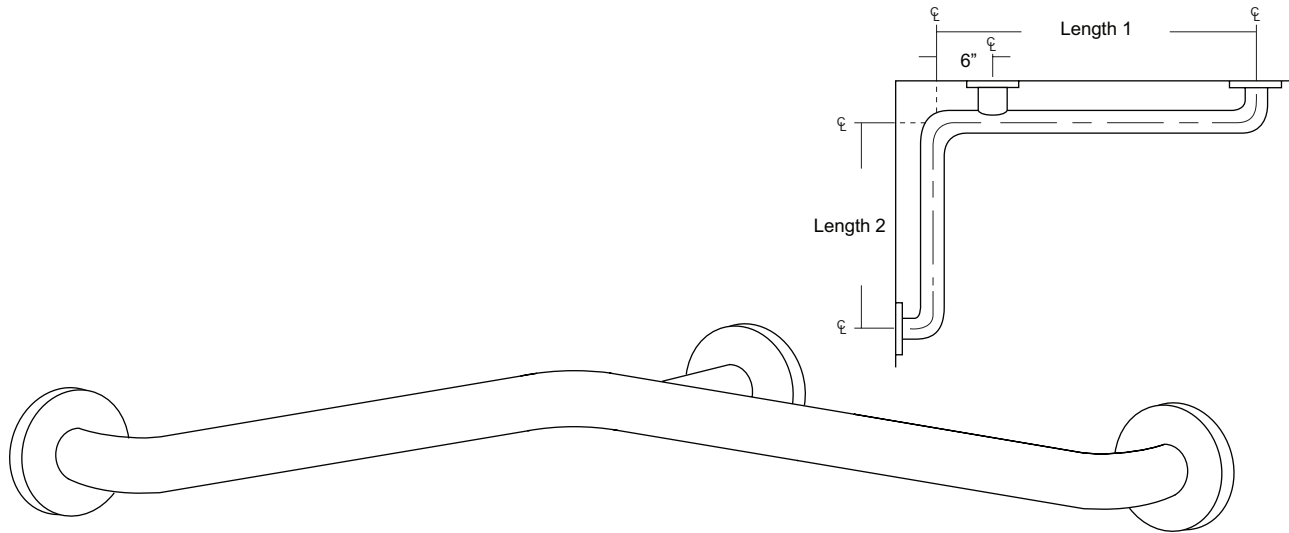

SPECIFICATIONS & INSTALLATION

Tubing: Fabricated of #18 ga stainless steel with a #4 satin finish. Available in 1 1/2" outside diameter. All bends are formed by an automatic mandrel bending process. All bars maintain a constant 1 1/2" offset.

Finish: Standard finish is a #4 satin finish. For a non-slip finish (peened) add suffix X to model number. (Ex. UG3X-G)

Flanges: Snap flanges are fabricated of 3" diameter, 3/8" deep drawn #22 ga stainless steel with #4 satin finish to match tubing. Flanges have dimples that secure over mounting plate.

Strength: Bars with a 1 1/2" offset clearance will support loads in excess of 900lbs when properly installed. Bars with greater offsets will support loads up to 250lbs when properly installed.

Installation: Before installing grab bars, verify with all state and local codes for requirements on bar diameter and type finish. Recommended mounting heights for grab bars are 33" - 36" centerline above finished floor. All mounting of grab bars when possible should have in wall mounting back plates. Find centerline mounting points and place bar on line making sure to be on center. Transfer mounting points (3 per flange) to wall. Drill pilot holes and secure bar with proper anchors per application. Snap cover over mounting plate.

Standard Lengths (Other sizes available upon request): 30" x 16", 30" x 18", 36" x 18", 36" x 24", 42" x 36", 54" x 36"

FLANGE INFORMATION

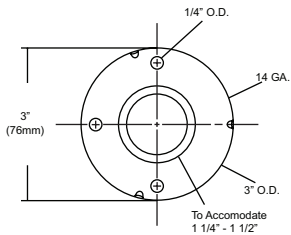

NOTES



UJ41 Series

Mop Holder & Hook Strip Combination Unit

Revision 03/11

JOB #:

ITEM #:

QUANTITY:

MOUNTING	HANDING	TYPE	SIZE	OTHER

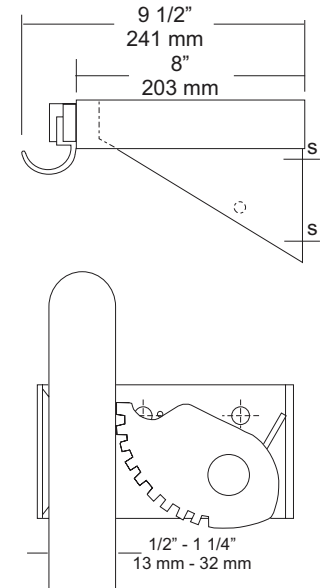
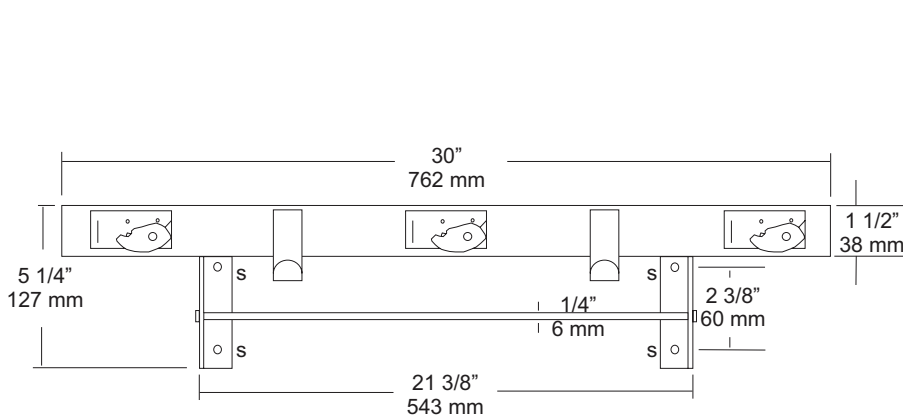

SPECIFICATIONS

- Shelf:** Fabricated of #18 ga stainless steel with a #4 satin finish, 8" deep (203mm) bent down 1 1/2" with 1/2" returns back for rigidity and safety.
- Mop Holders:** UJ19 plated reinforced steel with serrated cam type hard rubber mop or broom holder. Holds handles 1/2" to 1 1/4" diameter.
- Rag Hooks:** Fabricated of #18 ga stainless steel with a #4 satin finish.
- Mounting Brackets:** #16 ga stainless steel with exposed mounting points.
- Drying Rod:** 1/4" diameter stainless steel rod, secured to outside of support/mounting brackets with locking caps.
- Verify Style:**
- UJ41A:** 30"L (762mm) with 3 holders, 2 hooks.
- Rod Length:** 21 3/8" (565mm)
- UJ41B:** 36"L (914mm) with 4 holders, 3 hooks.
- Rod Length:** 27 3/8" (692mm)
- UJ41C:** 42"L (1066mm) with 5 holders, 4 hooks.
- Rod Length:** 33 3/8" (845mm)
- UJ41D:** 48"L (1219mm) with 6 holders, 5 hooks.
- Rod Length:** 39 3/8" (997mm)

INSTALLATION

Place unit to wall surface making sure unit is level and transfer mounting points. Drill pilot holes and secure unit with proper fasteners per application.

NOTES



UX112-BF

Double Robe Hook

Revision 12/11

JOB #:

ITEM #:

QUANTITY:

MOUNTING	HANDING	TYPE	SIZE	OTHER

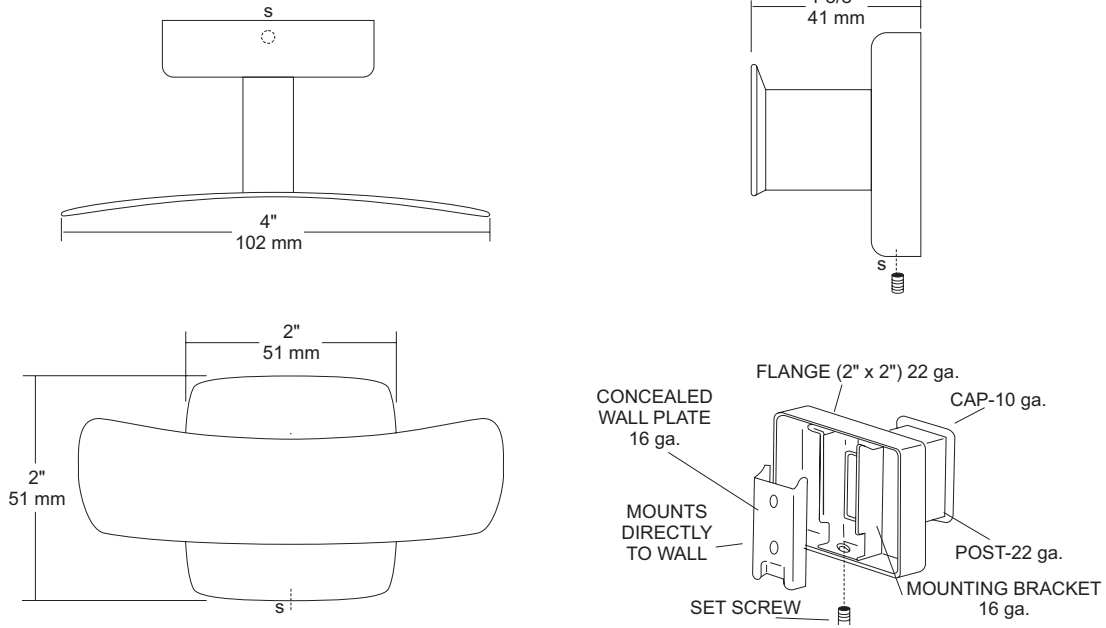

SPECIFICATIONS

UX Accessories: All UX bath accessories series are fabricated of stainless steel with a bright or satin finish. Mounting plates are concealed with a snap-on type plate secured by a set screw.

Hook: #10 ga stainless steel hook

Flange: 2" x 2" flange #22 ga stainless steel.

Post: #22 ga stainless steel.

Mounting Plate: #16 ga stainless steel concealed wall plate. Set screw secures mounting plate and flange.

Overall Size: 4"W x 2"H x 1 5/8"D

51mm x 51mm x 41mm

UX112-SF: Same as UX112-BF with satin finish.

INSTALLATION

Provide an area on wall surface at desired or specified location. Place concealed mounting plate on wall surface and transfer mounting points. Drill pilot holes and secure with proper fasteners. Place snap on flange over plate and secure with set screw.

NOTES

UX250P Vinyl Shower Curtain

Installation & Cleaning Instructions

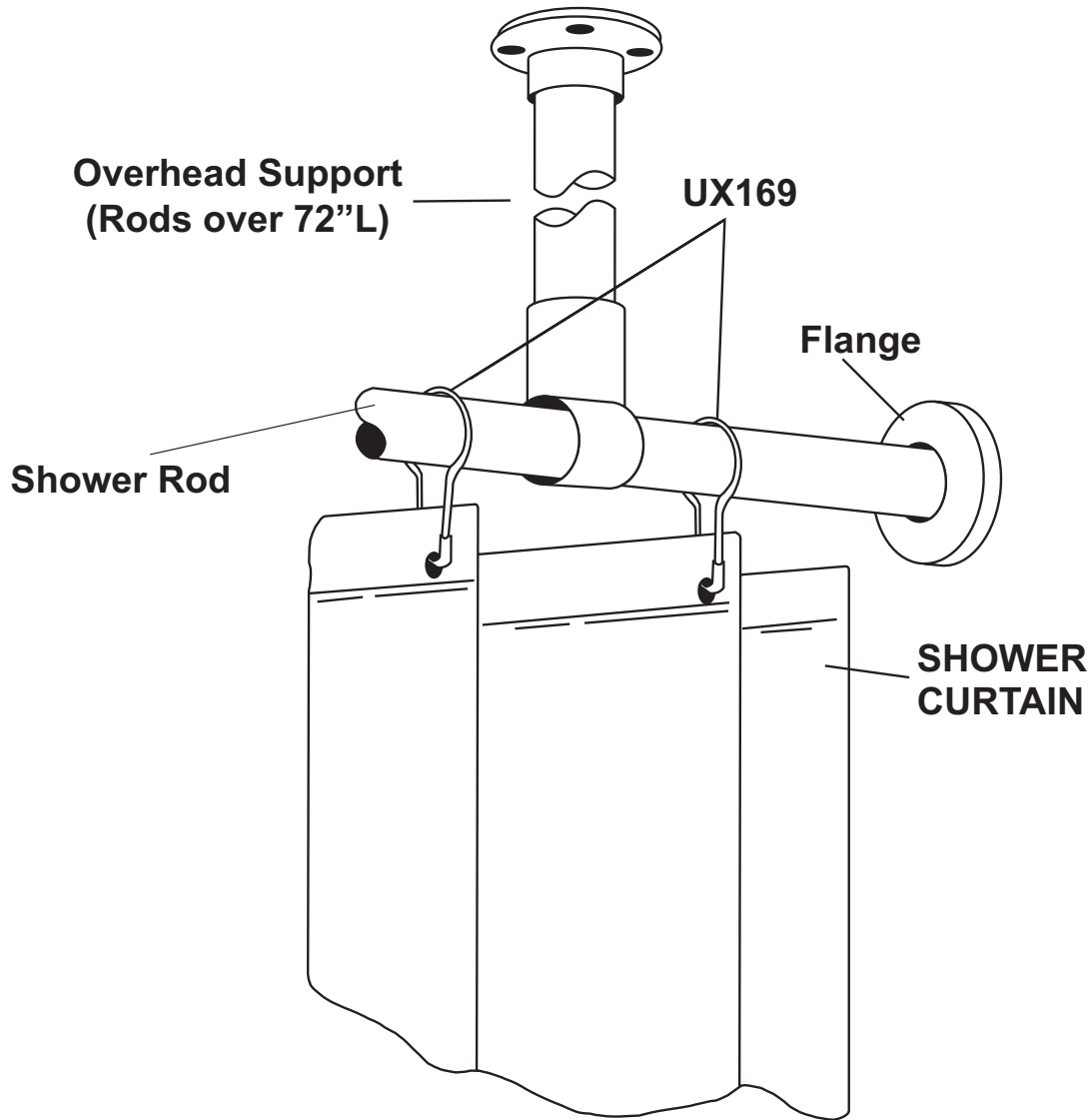

INSTALLATION

Recommended: UX169 stainless steel shower curtain hooks to connect to AJW shower curtain rods. Various types of flanges are available to secure rod and curtain to mounting surface (exposed and concealed).

Measuring Curtains: Curtains are measured W x H. The same curtain will fit a 1 or 1 1/4" diameter rod.

CARE & CLEANING

Machine wash cold water (not exceeding 41°C / 105°F). Do not bleach. Do not dry clean. Tumble dry low (not exceeding 140°F). Remove promptly.

JOB #:

ITEM #:

QUANTITY:

MOUNTING	HANDING	TYPE	SIZE	OTHER

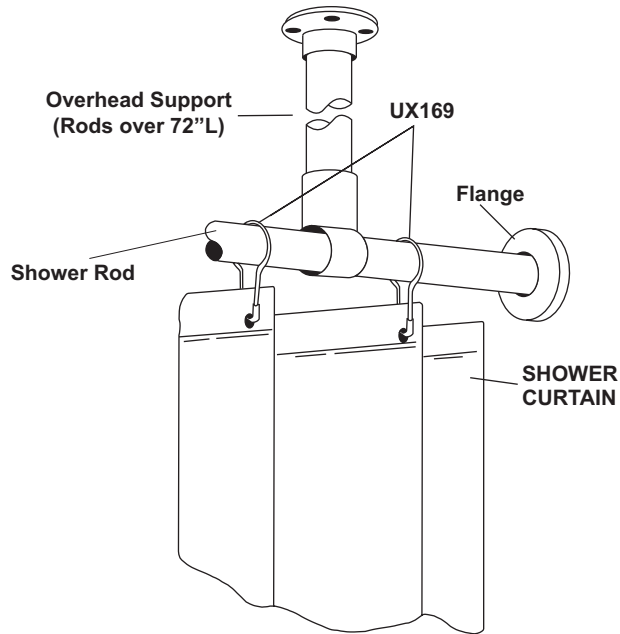

SPECIFICATIONS	INSTALLATION
----------------	--------------

Bacteria & Mildew Resistant: Heavy duty vinyl film (8 mil) that is flame retardant, durable and waterproof. Microbiotic KV-33 is an integral part added to the fabrication of this curtain that can be laundered repeatedly without losing this barrier against bacteria, fungus and mildew. KV-33 is a durable bacteriostat, mildewstat and fungistat that will provide protection for as long as you use this style curtain. It will retard the growth of organisms, thereby inhibiting odors caused by decaying bacteria.

Design: To insure the ultimate in bacteria free curtain, there are no side hems to hinder the flow-off of soap and water. This also makes cleaning easier. The heading is reinforced with a ten gauge vinyl film with rust proof anodized eyelets spaced 6" apart.

Cleaning: Sponge with warm mild soap and rinse with clear water.

Machine washing: Relatively cool water temp not to exceed 120 degrees F. DO NOT USE DETERGENTS. Air dry at low temp. Colors: Standard stock color is white. Special order for other colors are available on request.

***UX1-V/UX2-V:** Overhead s/s supports for oversized shower rods. (For shower rods over 72" in length an overhead support is recommended)

UX1-V: 1" OD shower rods.

UX2-V: 1 1/4" OD shower rods.

Recommended: UX169 stainless steel shower curtain hooks to connect to AJW shower curtain rods. Various types of flanges are available to secure rod and curtain to mounting surface (exposed and concealed).

Measuring Curtains: Curtains are measured W x H. The same curtain will fit a 1 or 1 1/4" diameter rod.

NOTES

Formerly Model #: 250P



UX2K
Flange & Shower Rod

Revision 03/11

JOB #:

ITEM #:

QUANTITY:

MOUNTING	HANDING	TYPE	SIZE	OTHER

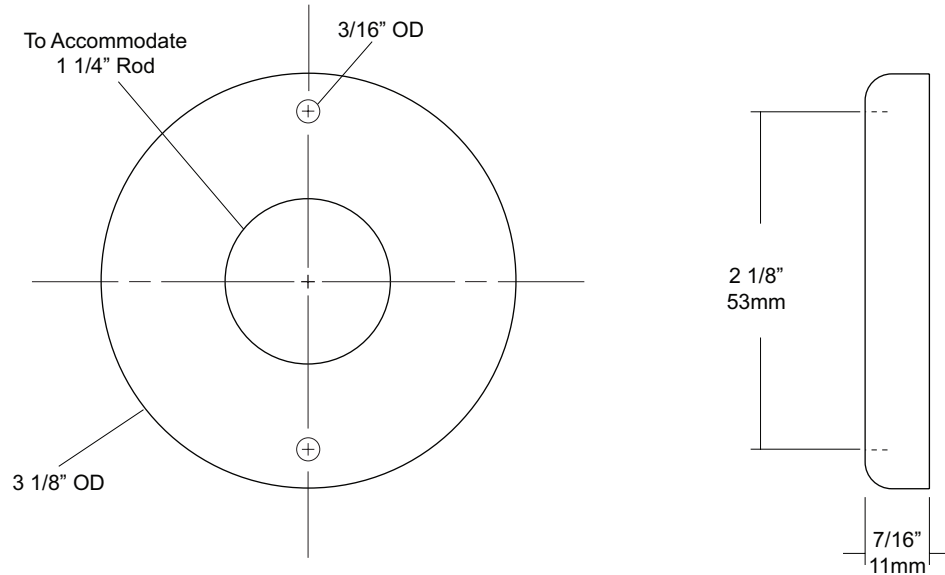

SPECIFICATIONS

Exposed Cover: Fabricated of #22 gauge stainless steel with a #4 satin finish. Cover has two (2) exposed mounting points.

Shower Rod: Fabricated of stainless steel with a #4 satin finish.

UX2: 1 1/4" outside diameter

INSTALLATION

Provide an area on wall surface at desired or specified location. Hold flange to wall surface and transfer mounting points. Drill pilot holes. Place flanges on the ends of the rods. Secure flanges to wall surface with proper fasteners per application.

NOTES