

date
projectname
attn
from
fax
email
phone

1/22/20
Lamar
Michelle Baird
Charlie Mills

mills.charlie63@gmail.com



U716 Series

Channel Frame Mirror & Shelf Combination

Revision 11/15

JOB #:

ITEM #:

QUANTITY:

MOUNTING	HANDING	TYPE	SIZE	OTHER

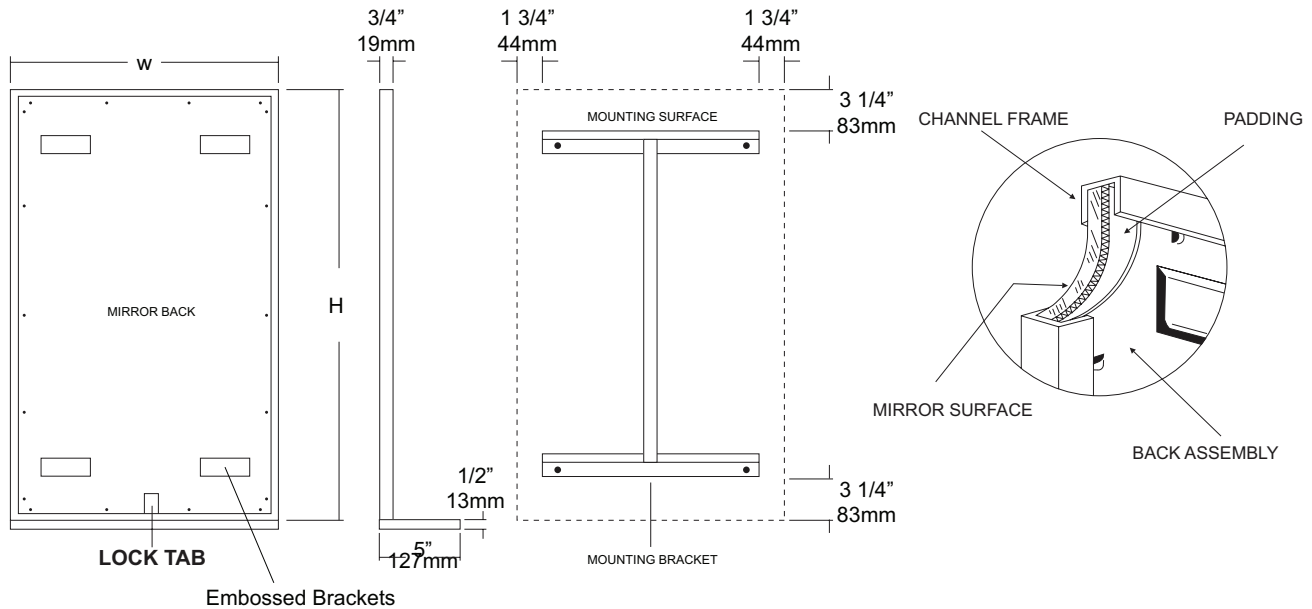

SPECIFICATIONS

Frame: Fabricated of #20 ga stainless steel, #4 satin finish. Roll formed 1/2" x 1/2" x 1/2" channel frame has mitered corners and secured with stainless steel rivet.

Mirror: 1/4" thick type 1 transparent flat type, class 1 - clear glass mirrors. Mirror is coated with silver and sealed with a uniform electrolytic copper plating, along with two coats of paint for added protection. Mirrors are guaranteed against silver spoilage for a period of 15 years. Mirrors conform to ASTM C1036 and ASTM C1503-R8.

Filler: Full size, 1/8" shock absorbing, water resistant, nonabrasive, polyethylene padding protects all concealed mirror surfaces.

Shelf: #18 ga stainless steel with #4 satin finish. Shelf is 5"d x full mirror width. All edges are turned down 1/2" with front turned back 1/2" for rigidity. #18 ga support bracket is welded to both frame and shelf, ground smooth.

Back: Fabricated of #20 ga pre-plated galvanized steel, with embossed horizontal louver mounting brackets. Embossed theft resistant pressure activated clip lock device, locks mirror in place to wall hangers.

Hangers: Fabricated of #20 ga pre-plated steel galvanized steel with mounting points.

Standard Sizes Available (W x H): 16"x24", 16"x30", 18"x24", 18"x30", 18"x36", 24"x30", 24"x36

Options:

- LG: Laminated Glass
- LX: Polycarbonate
- PM: Plastic Acrylic
- T: Tempered Glass
- VC: Vinyl Clad (Safety Glass)
- 8B: #8 Reflective Stainless Steel

*Stainless steel mirrors reflect images in different optic quality than plate glass. There will be a slight distortion which increases proportionately with the mirror size. Therefore, AJW Architectural Products™ cannot be held responsible for quality of image.

**Mirrors are always ordered Width x Height
 ***Recommended max size for 8B mirrors: 72" x 47-1/2"
 ****Framed mirrors are fabricated to a tolerance of (+/-) 1/8"
 ***** Mirrors conform to Federal Specifications DD-M-00411b & DD-g-541D

INSTALLATION

Coordinate installation with architect / contractor for specific mounting location and height for each mirror application. Making sure "I" bracket is level, transfer all mounting point locations to wall surface from drawing. Secure brackets with proper fasteners for each application. Slide mirror down over horizontal brackets until clip lock secures mirror in place. Mirror can only be removed by inserting tool through hole at bottom of frame depressing clip. This will allow mirror to slide up over brackets. Fillers are available if mirrors are mounted above and below tile line. (U004 Filler) filler material will match mirror frame to form a one piece construction.

To meet ADA Code, bottom edge of reflective surface can be no higher than 40" above finished floor. (4.19.6) Full length mirrors may be used for universal application when installed in correct locations.

Abrasive cleaners & chloric solutions should not be used on mirrors. Discoloring and /or scratching of frame and reflective surface may occur.

NOTES

Formerly Model #: U715 Series



U795 Series

Surface Mounted Tray

Revision 03/11

JOB #:

ITEM #:

QUANTITY:

MOUNTING	HANDING	TYPE	SIZE	OTHER

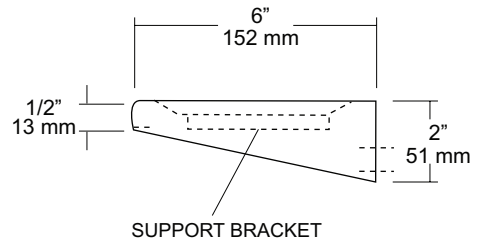
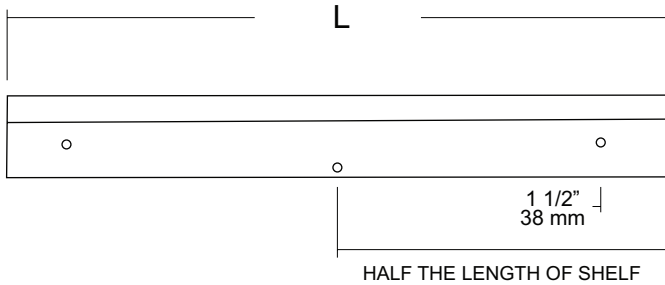
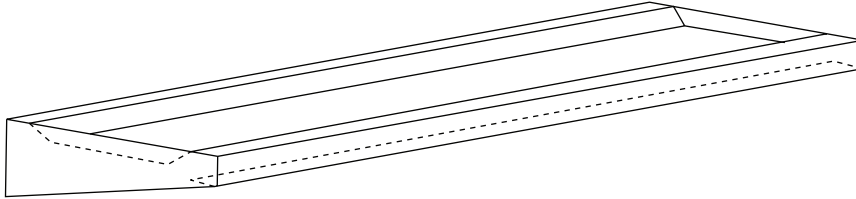

SPECIFICATIONS

Shelves: #18 ga stainless steel. Shelf ends are closed and permanently welded. Front edge is turned down 1/2" back for maximum rigidity. All corners are heliarc welded, ground and polished smooth. Shelf center is 3/8" deep recess to prevent rolling of articles placed on unit. All exposed surfaces have a #4 satin finish.

Standard Lengths: 12", 16", 18", 24"

Shelf Depth: Surface mounted shelf 6"D.

INSTALLATION

Provide an area on wall surface at desired or specified location. Place unit up to wall making sure unit is level. Transfer mounting points to surface and drill pilot holes. Secure shelf to surface with proper fasteners per each application.

NOTES



UC12

Double Robe Hook

Revision 03/11

JOB #:

ITEM #:

QUANTITY:

MOUNTING	HANDING	TYPE	SIZE	OTHER

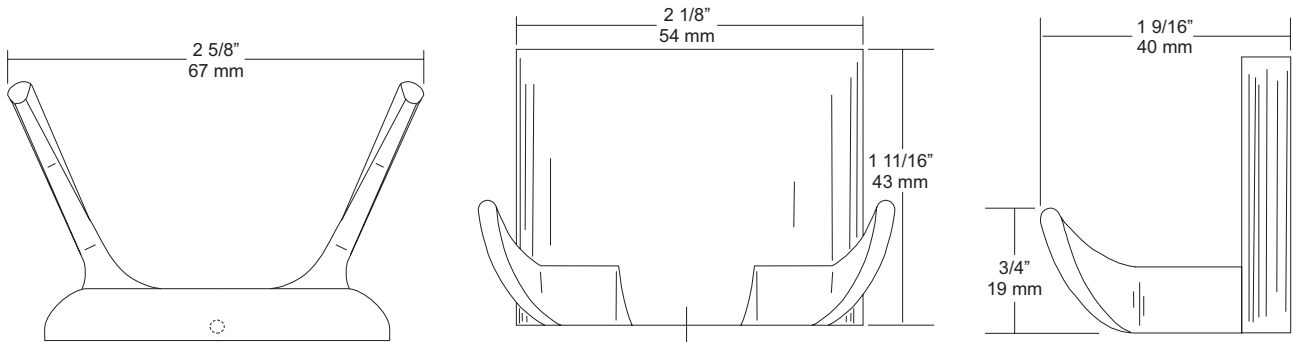

SPECIFICATIONS

UC Accessories: All accessories are fabricated of high polished chrome plating over virgin zinc die cast. All UC items comply with standard federal specifications.

Overall Size: 2 5/8"W x 1 11/16"H x 2 9/16"D
67mm x 44mm x 40mm

INSTALLATION

Place concealed mounting bracket on wall surface at desired location. Transfer mounting points and drill pilot holes. Secure plate with proper fasteners per application. Place item over plate making sure it fits snugly and secure on the underside with supplied set screw.

NOTES



UJ30 Series

Hook Strip with Shelf Combination Unit

Revision 03/11

JOB #:

ITEM #:

QUANTITY:

MOUNTING	HANDING	TYPE	SIZE	OTHER

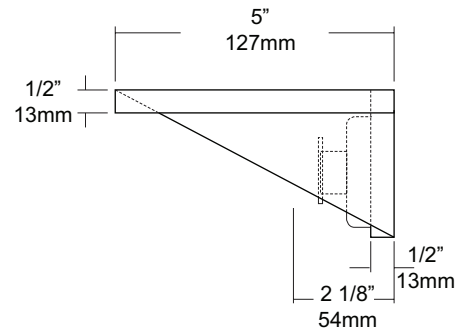
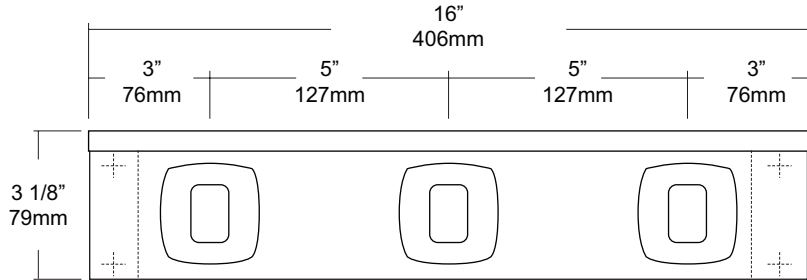

SPECIFICATIONS INSTALLATION

Shelf: Fabricated of #18 ga stainless steel with a #4 satin finish, 5" deep (203mm) bent down 1 1/2" with 1/2" returns back for rigidity and safety.

Hook Strip: #18 gauge stainless steel satin finish.

Mounting Brackets: #16 ga stainless steel with exposed mounting points.

Hooks: Satin finish UX110-SF hooks stainless steel single hooks.

Verify Style:

UJ30A: 16"L (406mm), 3 hooks.

UJ30B: 26"L (660mm), 4 hooks.

UJ30C: 36"L (914mm), 5 hooks.

Place unit to wall surface making sure unit is level and transfer mounting points. Drill pilot holes and secure unit with proper fasteners per application.

NOTES



UJ31 Series

Hook Strip with Shelf Combination Unit

Revision 03/11

JOB #:

ITEM #:

QUANTITY:

MOUNTING	HANDING	TYPE	SIZE	OTHER

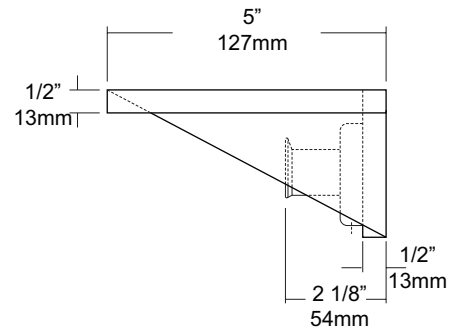
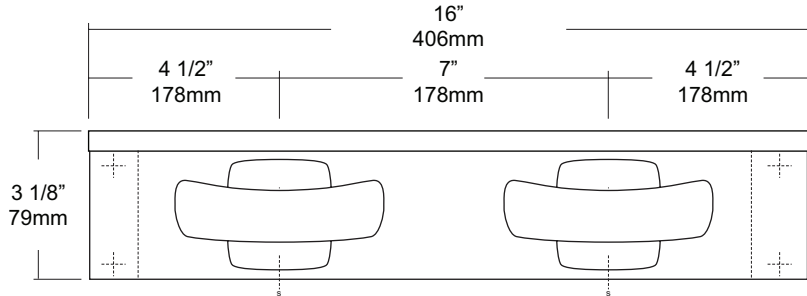

SPECIFICATIONS	INSTALLATION
----------------	--------------

Shelf: Fabricated of #18 ga stainless steel with a #4 satin finish, 5" deep (127mm) bent down 1 1/2" with 1/2" returns back for rigidity and safety.

Hook Strip: #18 gauge stainless steel satin finish.

Mounting Brackets: #16 ga stainless steel with exposed mounting points.

Hooks: Satin finish UX112-SF hooks stainless steel dual hooks.

Verify Style:

UJ31A: 16"L (406mm), 2 hooks.

UJ31B: 26"L (660mm), 3 hooks.

UJ31C: 36"L (914mm), 4 hooks.

Place unit to wall surface making sure unit is level and transfer mounting points. Drill pilot holes and secure unit with proper fasteners per application.

NOTES

JOB #:

ITEM #:

QUANTITY:

MOUNTING	HANDING	TYPE	SIZE	OTHER

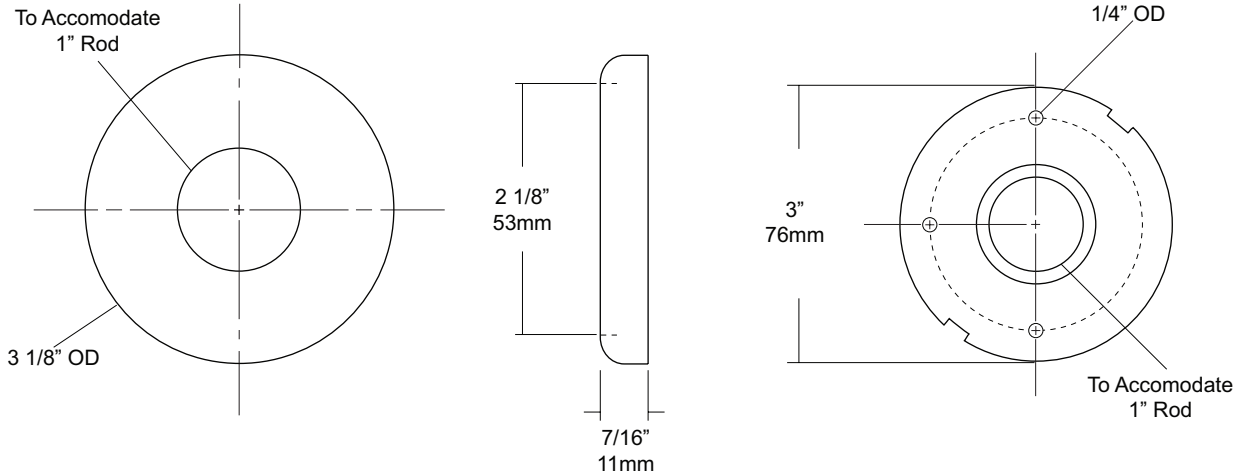

SPECIFICATIONS

Concealed Mounting Plate: #14 gauge stainless steel with three (3) mounting points to secure to mounting surface and three (3) dimples that secure snap cover escutcheon.

Snap Cover: Fabricated of #22 gauge stainless steel with a #4 satin finish. Cover snaps over mounting plate to provide a concealed mounting application.

Shower Rod: Fabricated of 18 gauge stainless steel with a #4 satin finish.

UX1: 1" outside diameter

INSTALLATION

Provide an area on wall surface at desired or specified location. Hold flange to wall surface and transfer mounting points. Drill pilot holes. Place flanges on the ends of the rods. Secure flanges to wall surface with proper fasteners per application.

NOTES

JOB #:

ITEM #:

QUANTITY:

MOUNTING	HANDING	TYPE	SIZE	OTHER

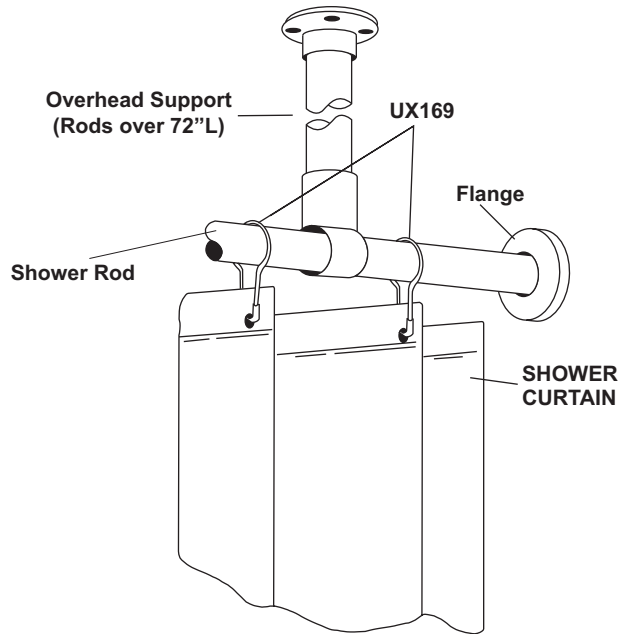

SPECIFICATIONS	INSTALLATION
----------------	--------------

U250A: Fully reinforced, wide top hem and reversed bottom hem to prevent water and soap from collecting. Each is equipped with rust proof nickel grommets spaced aprx. 6" on center and down 3/4" from top edge. When determining size of curtain required, consider the desired fullness and add 10" to the shower rod length.

U250A: Anti-Bacterial, flame resistant, self deodorizing fabric. Fabric is non-toxic and contains a patented dual agent antimicrobial system. Provides around the clock effectiveness against cross-infection hazards, reducing growth of viable diseases and odor forming organisms on their surfaces. Curtains are flame resistant and offer permanent protection against the dangers of accidental fires.

Curtain Hooks (UX169): Unit is constructed of stainless steel. Ring snaps around the shower rod to support curtain. Spacing of hooks is every 6" and can be installed on both 1" & 1 1/4" diameter rods.

Colors Available: White, Beige, Medium Blue, Green, Mauve, Frosty, Blush, Claret, Parchment, Yellow & Jade.

***UX1-V/UX2-V:** Overhead s/s supports for oversized shower rods. (For shower rods over 72" in length an overhead support is recommended)

UX1-V: 1" OD shower rods.

UX2-V: 1 1/4" OD shower rods.

Recommended: UX169 stainless steel shower curtain hooks to connect to AJW shower curtain rods. Various types of flanges are available to secure rod and curtain to mounting surface (exposed and concealed).

Measuring Curtains: Curtains are measured W x H. The same curtain will fit a 1 or 1 1/4" diameter rod.

NOTES

Formerly Model #: 250A



UX901

Adjustable Shaving & Makeup Mirror

Revision 10/14

JOB #:

ITEM #:

QUANTITY:

MOUNTING	HANDING	TYPE	SIZE	OTHER

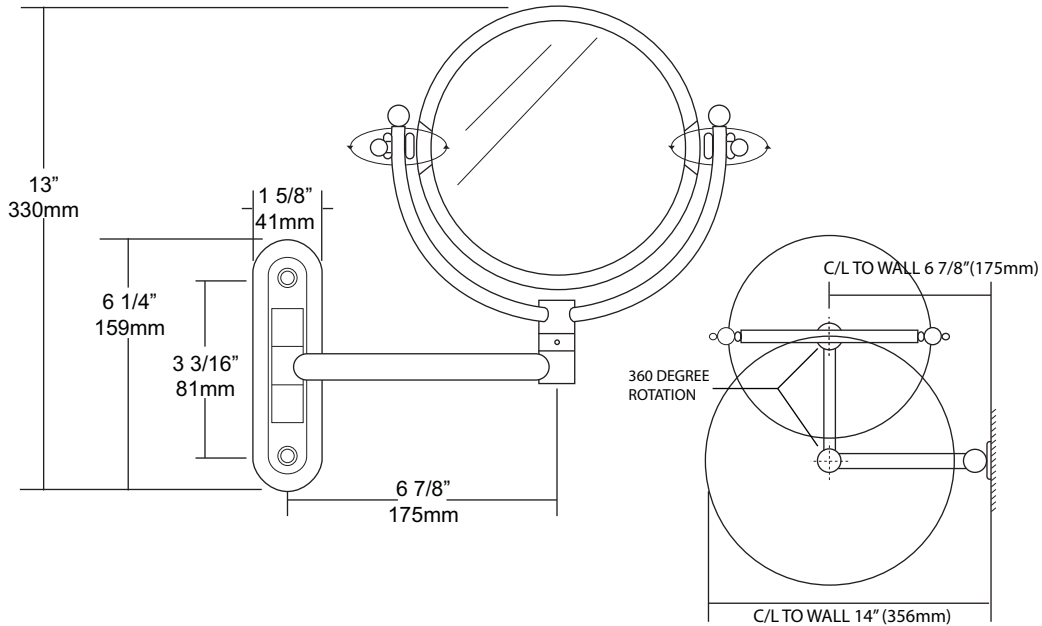

SPECIFICATIONS

Mirror Bracket: Fabricated of high polished chrome finish. Set screw on arm below mirror has an adjustable set screw that allows mirror to rotate 360 degree's or remain in one locked position. Maximum projection from wall surface is 14" centerline of support post. One side of mirror has a 2.5X magnification and the other side is 4X.

Overall Size: 13"H x 14" Max Depth (c/l)
330mm x 356mm

INSTALLATION

Place mirror on wall surface. Extend arm to the maximum in all directions to avoid interference with any obstacle. Transfer mounting points to wall surface and drill pilot holes. Secure with proper fasteners per each application.

NOTES

Formerly Model #: U901