

date
projectname
attn
from
fax
email
phone

10-18-2016
Adult Crisis Center
Donya
Donya
dyost@division10sales.com
7046445313

Care, Cleaning, and Maintenance Instructions – Washroom Accessories

With proper care and cleaning, as well as routine maintenance, you will help to maximize the life of your AJW accessories. Please refer to these procedures when maintaining our products:

Stainless Steel Surfaces:

Wipe stainless steel cabinets with a soft cloth, rubbing with the grain to prevent scratching the surface. The grain of AJW's stainless steel cabinets runs in a vertical direction. Do not use abrasive cleaners containing chloric solutions on stainless steel. Avoid cleaning products that contain hydrochloric acids, bleach, or chlorides.

Soap Dispensers:

The majority of operational issues with soap dispensers are due to improper maintenance and lack of cleaning. Soap tanks, valves, and globes should be cleaned periodically to avoid sludge and soap build up, thus promoting better operation. When soap dispensers are left unmaintained for long periods of time, the soap could potentially dry out inside the valve mechanism, causing clogs or leaking. While cleaning, do not remove or take valves apart as this creates problems with the seals and may cause a bypass leak. Flush valves with warm water. If the water does not flow through the valve after cleaning, repeat the procedure until it does.

Take care to make sure you are using the right soap in your soap dispensers. The proper viscosity is imperative for trouble free operation. AJW recommends that the soap viscosity should be at least 95 cps, and no more than 2500 cps for use in all AJW soap dispensers. Coconut oil soaps should be the only products used in liquid valve soap dispensers. We recommend that you use a standard liquid, non-chloric soap, which should be mixed in a solution of one part water to one part soap. We recommend free-flowing, thin viscosity soaps only.

JetAir Hand Dryers:

Begin the cleaning procedure by disconnecting the electrical supply. Using the allen key supplied, remove all tamper-resistant screws and lift the cover of the dryer off of the base, and clear dust and lint from the inside of the machine and cover. When you have finished cleaning, reinstall the cover onto the base and secure with tamper-resistant screws. Wipe cover with a damp cloth; do not use abrasive cleaners. Clean the inner cover and internal mechanism periodically to ensure proper operation.

Note: Hand Dryer maintenance that is performed inside the cover should not be done by unqualified personnel.

Mirrors:

Wipe mirror frames with a soft cloth, making sure to rub stainless steel frames with the grain to avoid scratching. Do not use abrasive cleaners containing chloric solutions on stainless steel frames.

Mirror glass should be cleaned by spraying cleaner on a soft cloth, and then wiped onto the mirror (it is best if cleaner is not sprayed directly onto the mirror). This will ensure that cleaning agents do not run down the mirror and into the frame. If a cleaning agent and/or still water is allowed to sit in a frame or on the back of a mirror, it will lead to a de-lamination of the protective coating, and/or the mirror silver, voiding the AJW warranty.

Note: Soap dispensers should not be mounted directly on a mirror surface, as soap residue and water from a person's hand can be splashed into the mirror frame, causing the same de-lamination as described above.

Corrosive Chemical / Surface Rust Alert

Stainless steel is very resistant to rust, however it is not entirely impervious to it. Proper care, especially under corrosive conditions is needed. Cleaning your stainless steel surface using the instructions above is necessary, but it is also important to keep your stainless steel surface free from contaminants.

The below listed substances will react with stainless steel to produce rust and corrosion. These elements are commonly used in caustic cleaning agents, and should never be used to clean stainless steel washroom accessories. The most common elements that react adversely with stainless steel include:

Bromide
Chloride
Fluoride
Iodine

Other common acids and compounds cause significant damage to stainless steel. Stainless steel will sustain permanent discoloration and/or corrosion if the material comes into contact with even vapor fumes from these substances. The following acids and compounds should never be used to clean any stainless steel product:

Acetic Acids
Nitric Acids
Phosphoric Acids
Hydrochloric / Muriatic Acids
Sodium Chlorides (contains salt)
Sodium Hydrochloride (Bleach)
Sodium Hydroxide
Sulfuric Acids



Some other conditions that can cause stainless steel to corrode, discolor, or develop surface rust are:

1. Contact with Muriatic Acid (commonly used to clean up after tile or concrete installation).
2. Soap residue (chemical additives will cause discoloration and dried soap residue actually looks like rust).
3. Water with high iron content can leave a rusty residue, especially after continuous contact.

Surface Rust Removal

If your stainless steel surface is exposed to any of the contaminants above, please follow the instructions below to remove any discoloration:

- Wash affected accessory with a mild dish detergent and warm water.
- Dry all surfaces with a towel or soft cloth.
- Using a dry Scotch Brite pad, rub all surfaces until rust marks are completely removed. Be sure to rub in the direction of the grain to prevent scratching. Grab bars may be cleaned using a rotating motion, as the grain is random in these products. Do not use on bright polish stainless steel.
- Rinse with a damp cloth and dry with a soft cloth.

JOB #:

ITEM #:

QUANTITY:

MOUNTING	HANDING	TYPE	SIZE	OTHER

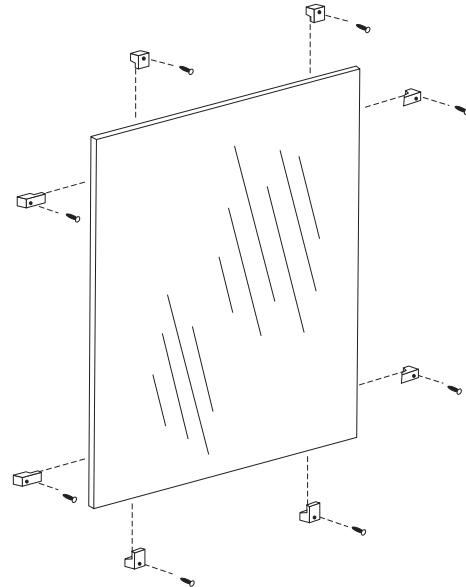
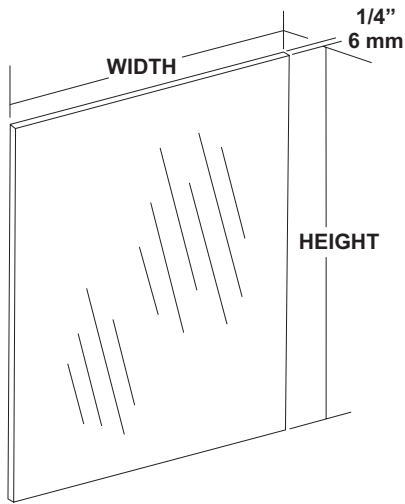

SPECIFICATIONS

Mirror: 1/4" thick type 1 transparent flat type, class 1 - clear glass mirrors. Mirror is coated with silver and sealed with a uniform electrolytic copper plating, along with two coats of paint for added protection. All frameless mirrors have polished edges. Mirrors are guaranteed against silver spoilage for a period of 15 years. Mirrors conform to ASTM C1036 and ASTM C1503-R8.

Recommended size one piece glass is 96" x 96"

Optional Surfaces and Sizes:

- PM: Plastic Mirrors (96" x 48" max size)
- LG: Laminated Glass (96" x 48" max size)
- BE: Beveled Edge Mirror: 1/4" plate glass with 1/2" Beveled Edge (72" x 60" max size)
- VC: Vinyl Clad (96" x 96")

***NOTE:** For oversized mirrors, recommend using U717 "J" mold style mirrors (Bottom, Top & Bottom or 4 sided) See U717 tech data sheet for more information.

Mounting Options:

- CL: Lucite Mirror Clips: (6 clips per pack)
- SCL: Stainless Steel Clips: (6 clips per pack)
- BCL: Lucite Mirror clips for beveled edge mirrors.

These Mirrors are always ordered Width x Height

Frameless mirrors are fabricated to a tolerance of ± 1/16"
Mirrors conform to Federal specification DD-M-00411b.

INSTALLATION

Provide an area on wall surface at desired or specified location. Select the proper clips for mounting. Mount the bottom clips approx. 1" in from each side of the overall width of the mirror. Place a level across the clips to make sure mirror will be level. Place glass on clips and check with level again. Follow same procedures for other clips. For oversized glass, it is recommended to have a minimum of a bottom "J" mold style mounting frame.

***Note:** Recommend 8 sq ft of glass per 1 pack of plastic clips. 8 sq ft of glass for stainless clips. The bottom reflective surface edge must be mounted 40" above finished floor to comply with ADA code, 4.19.6.

NOTES



U7018B Series

Stainless Steel Frameless Mirror

Revision 06/11

JOB #:

ITEM #:

QUANTITY:

MOUNTING	HANDING	TYPE	SIZE	OTHER

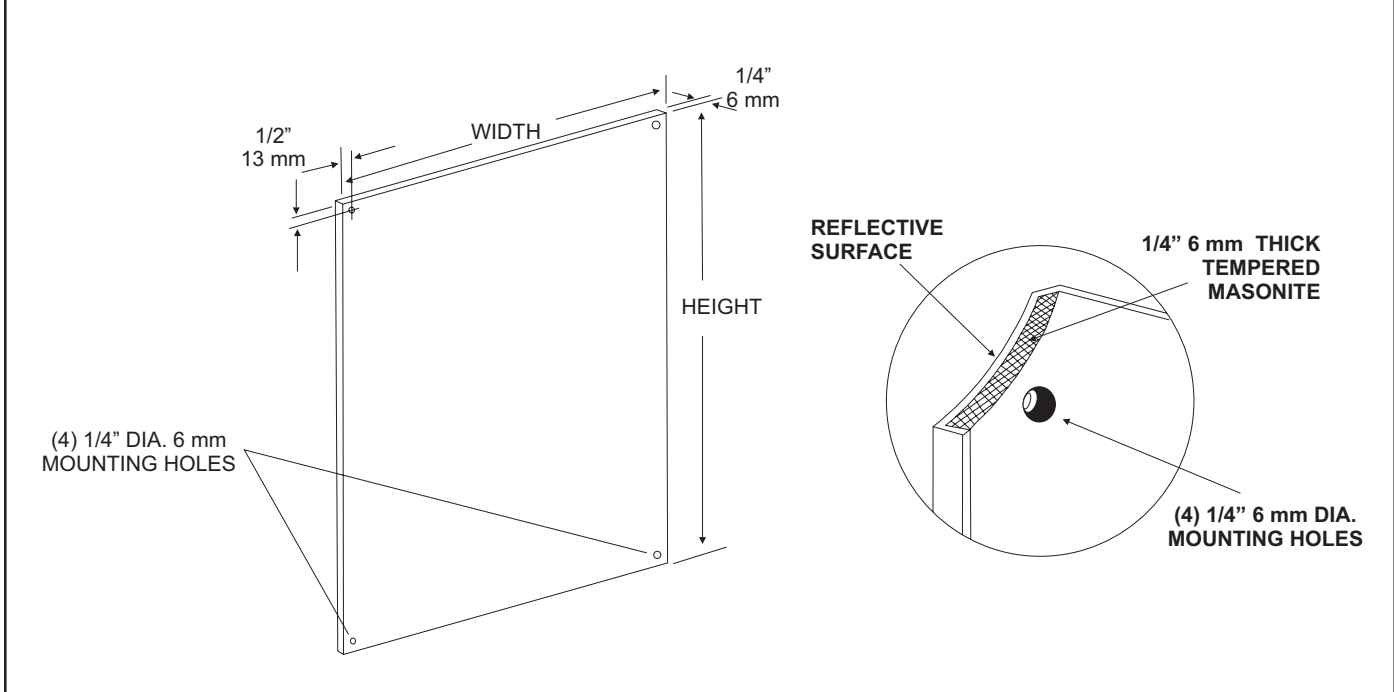

SPECIFICATIONS INSTALLATION

Mirror: Type 304 #20 ga stainless steel with #8B architectural finish. Both mirrors have 1/4" returns to wall surface for rigidity surrounding 1/4" thick tempered masonite backing. 1/4" diameter exposed mounting points are provided. Each mirror is shipped with a removable vinyl protective coating.

Note: Stainless steel mirrors reflect images in different optic quality than plate glass. There will be a slight distortion which increases proportionately with the mirror size. Therefore we cannot be held responsible for quality of image.

Cleaning: Non-abrasive and non-chloric solutions should be used to clean stainless steel mirrors.

These Mirrors are always ordered Width x Height

Provide an area at desired or specified location and strike a line that is level. Place mirror at this line and check again with level. Transfer mounting locations to wall surface and drill pilot holes. Peel off vinyl coating around corners only before securing to wall. Secure mirror with proper fasteners per each application. Do not over tighten fasteners. If a depression is formed by over-tightening the reflective quality may be affected. Remove remainder of vinyl coating after mirror checks with level and is properly secured. The bottom reflective surface edge must be mounted 40" above finished floor to comply with ADA code, 4.19.6.

NOTES

U7018B

Installation Instruction Sheet

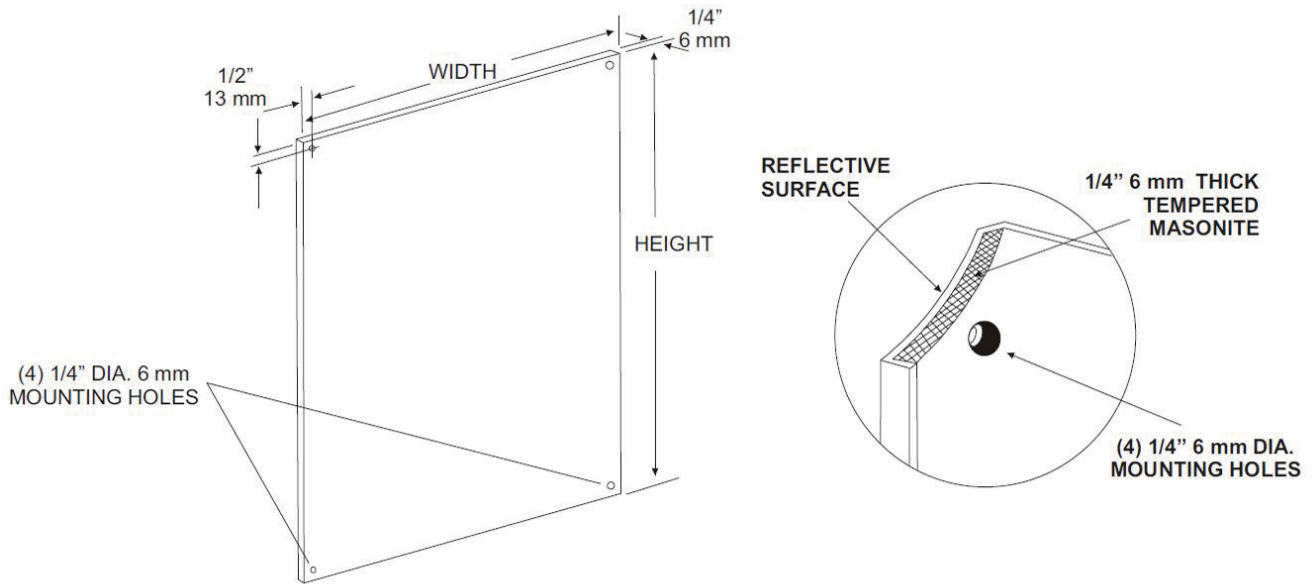

INSTALLATION

Provide an area at desired or specified location and strike a line that is level. Place mirror at this line and check again with level. Transfer mounting locations to wall surface and drill pilot holes. Peel off vinyl coating around corners only before securing to wall. Secure mirror with proper fasteners per each application. Remove remainder of vinyl coating after mirror checks with level and is properly secured. The bottom reflective surface edge must be mounted no higher than 40" above finished floor to comply with ADA code, 4.19.6.

CARE & CLEANING

Wipe mirrors with a soft cloth, taking special care not to rub stainless steel mirrors in a circular motions to avoid scratching. Do not use abrasive cleaners containing chloric solutions on stainless steel mirrors. Glass Plus or other window cleaning products are ideal.

U701 Installation Instruction Sheet

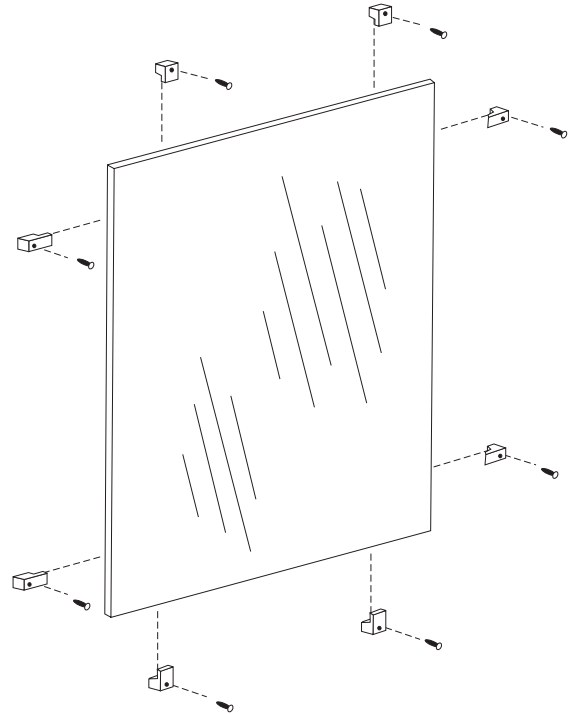
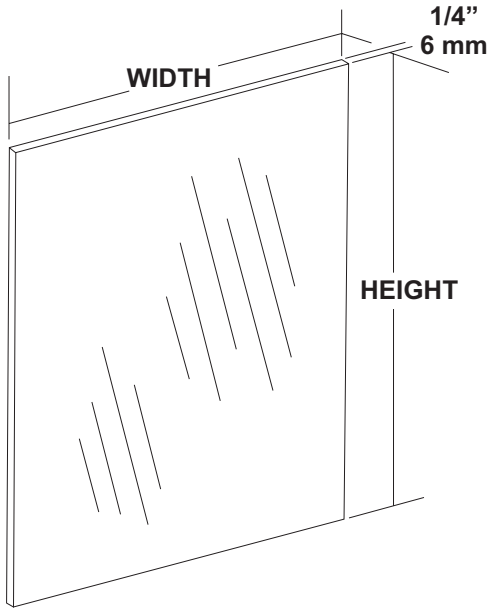

INSTALLATION

Provide an area on wall surface at desired or specified location. Select the proper clips for mounting. Mount the bottom clips aprx. 1" in from each side of the overall width of the mirror. Place a level across the clips to make sure mirror will be level. Place glass on clips and check with level again. Follow same procedures for other clips. For oversized glass, it is recommended to have a minimum of a bottom "J" mold style mounting frame.

*Note: Recommend 8 sq ft of glass per 1 pack of plastic clips. 8 sq ft of glass for stainless clips. The bottom reflective surface edge must be mounted 40" above finished floor to comply with ADA code, 4.19.6.

CARE & CLEANING

Wipe mirrors with a soft cloth, taking special care to rub stainless steel frames with the grain to avoid scratching. Do not use abrasive cleaners containing chloric solutions on stainless steel frames. Glass Plus or other window cleaning products are ideal.



UG3-A

Grab Bars

Revised 03/11

JOB #:

ITEM #:

QUANTITY:

MOUNTING	HANDING	TYPE	SIZE	OTHER



SPECIFICATIONS & INSTALLATION

Tubing: Fabricated of #18 ga stainless steel with a #4 satin finish. Available in 1 1/2" outside diameter. All bends are formed by an automatic mandrel bending process. All bars maintain a constant 1 1/2" offset.

Finish: Standard finish is a #4 satin finish. For a non-slip finish (peened) add suffix X to model number. (Ex. UG3X-A)

Flanges: Snap flanges are fabricated of 3" diameter, 3/8" deep drawn #22 ga stainless steel with #4 satin finish to match tubing. Flanges have dimples that secure over mounting plate.

Strength: Bars with a 1 1/2" offset clearance will support loads in excess of 900lbs when properly installed. Bars with greater offsets will support loads up to 250lbs when properly installed.

Installation: Before installing grab bars, verify with all state and local codes for requirements on bar diameter and type finish. Recommended mounting heights for grab bars are 33" - 36" centerline above finished floor. All mounting of grab bars when possible should have in wall mounting back plates. Find centerline mounting points and place bar on line making sure to be on center. Transfer mounting points (3 per flange) to wall. Drill pilot holes and secure bar with proper anchors per application. Snap cover over mounting plate.

Standard Lengths (Other sizes available upon request): 12", 16", 18", 24", 30", 32", 36", 42", 48", 50", 52", 54", 56"

FLANGE INFORMATION

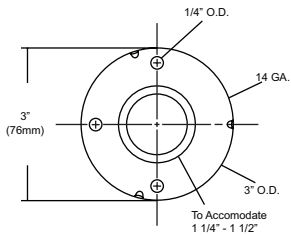

NOTES



US130-A Series

Security Straight Grab Bar

Revision 09/11

JOB #:

ITEM #:

QUANTITY:

MOUNTING	HANDING	TYPE	SIZE	OTHER

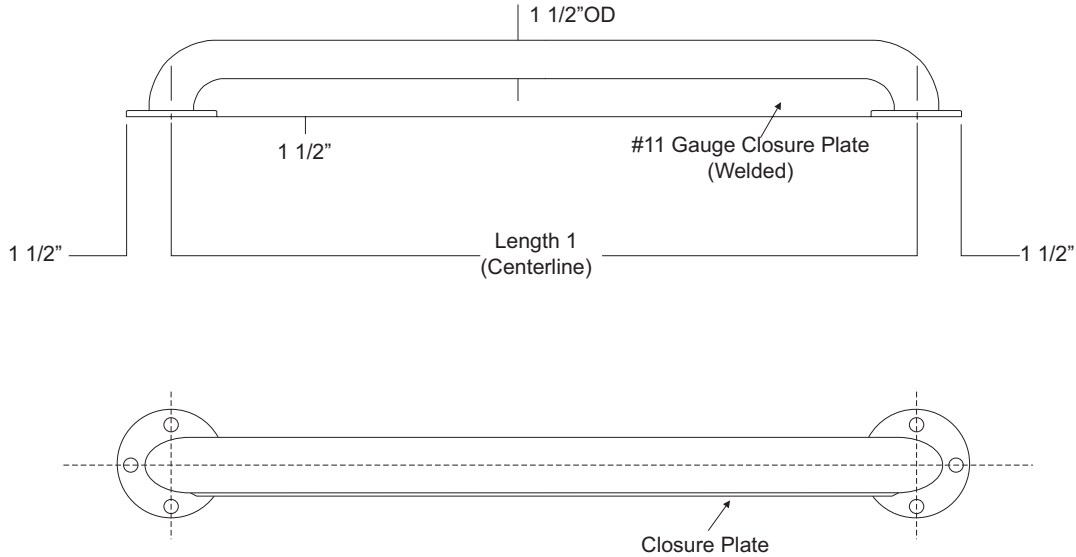

SPECIFICATIONS

Tubing: Fabricated of #18 ga stainless steel with a #4 satin finish and 1 1/2" outside diameter. All bends are formed by an automatic mandrel bending process. All bars maintain a constant 1 1/2" offset.

Flanges: Fabricated of 3" diameter, #11 ga stainless steel with #4 satin finish to match tubing. Flanges are heliarc welded to bar to form a one piece construction. Each flange has three (3) mounting points (1/4" dia.)

Closure Plate: Fabricated of #11 gauge stainless steel welded to the underside of the bar.

Strength: Bars that provide a 1 1/2" offset can support loads in excess of 900 lbs when properly installed. Other configurations can support loads excess of 250 lbs when properly installed. Grab bars must be installed properly to support the loads intended.

US130: Security Grab Bar, satin finish

US130X: Security Grab Bar, non-slip finish

"A" Style: 12" min. to 48" max. centerline dimension.

***When measuring and ordering grab bars, remember bars are sized centerline to centerline.**

***Grab Bars comply with ADA Code 4.26.2**

***Non-chloric and non-abrasive cleaners should be used to clean surface of bars and flanges.**

INSTALLATION

Before installing grab bars, verify with all state and local codes for requirements on bar diameter and type finish. Recommended mounting heights for grab bars are 33" - 36" centerline above finished floor. All mounting of grab bars when possible should have in wall mounting back plates. Find centerline mounting points and place bar on line making sure to be on center. Transfer mounting points (3 per flange) to wall. Drill pilot holes and secure bar with proper anchors per application.

NOTES



US75

Security Mount Toilet Tissue Holder

Revision 12/13

JOB #:

ITEM #:

QUANTITY:

MOUNTING	HANDING	TYPE	SIZE	OTHER

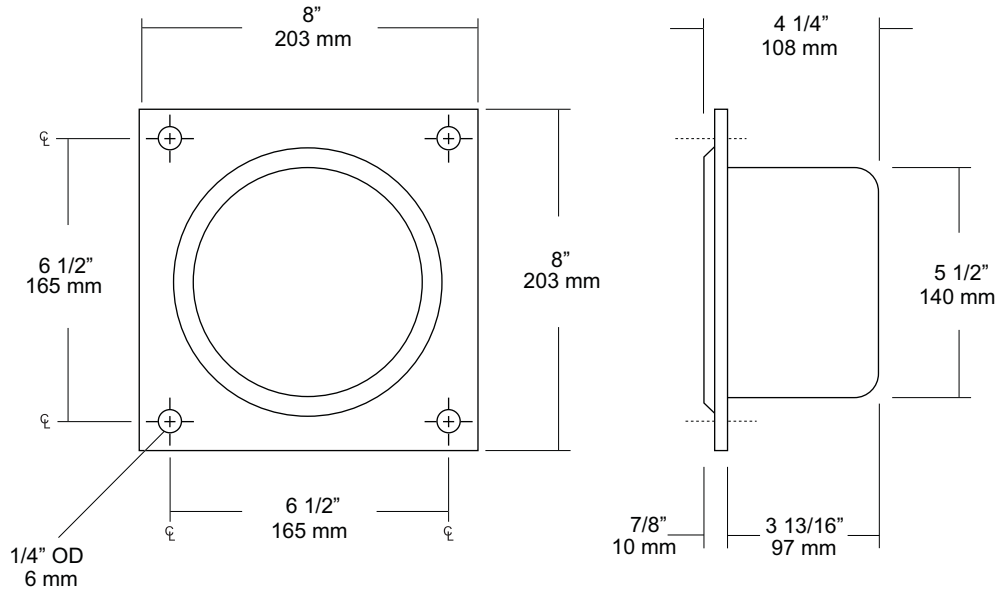

SPECIFICATIONS

Tissue Holder: Toilet tissue holder is fabricated of #16 gauge stainless steel with a satin finish on all exposed surfaces. Unit is a drawn one-piece construction. Rim is beveled to form a snug fit against square flange.

Flange: Fabricated of #16 gauge stainless steel with a satin finish with four (4) 1/4" dia. mounting points. Flange is a separate piece secured to deep drawn tissue holder.

Overall Size: 8"W x 8"H" x 4 1/4"D

203mm x 203mm x 108mm

Wall Opening: 5 3/4" diameter x 4"D

146mm x 121mm

Capacity: One standard size roll with a 5 1/4" (133mm) OD

INSTALLATION

Coordinate installation with contractor or architect to avoid interference with pipes, vents, etc. In wall. Provide a wall opening on 5 3/4" diameter. Minimum wall depth required is 4"D. Transfer flange mounting points to wall surface. Drill four (4) points for fasteners per application. Secure unit with proper fasteners. Theft resistant fasteners are not provided.

Toilet Paper Dispensers: All dispensers that are to meet ADA code cannot have any type of controlled delivery. (4.16)

NOTES



UX76-BF

Toilet Tissue Dispenser

Revision 10/14

JOB #:

ITEM #:

QUANTITY:

MOUNTING	HANDING	TYPE	SIZE	OTHER

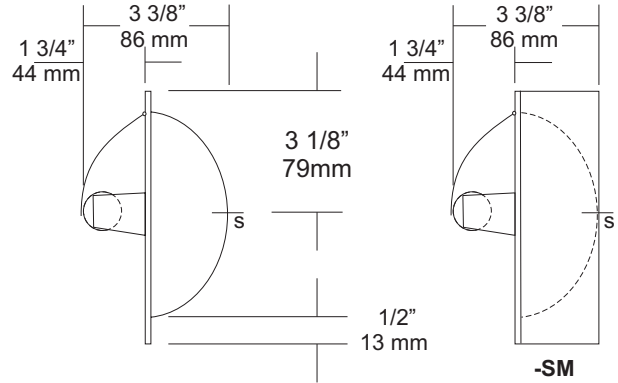
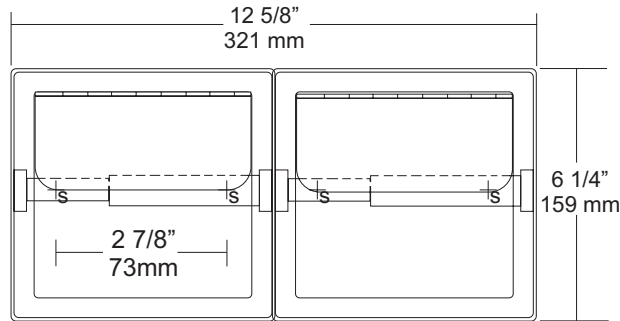

SPECIFICATIONS

Shell and Flange: Drawn one piece construction fabricated of #22 ga stainless steel with a bright finish. Two mounting points allow unit to be secured to mounting clamps or framing in wall opening.

Hood: Fabricated of bright stainless steel, secured to shell by a welded hinge.

Support Posts: Heavy duty cast Zamac with bright chrome finish to match shell.

Spindle: Spring loaded, chrome plated plastic roller.

Collars: #22 ga stainless steel finished to match unit.

Overall Size: 12 5/8"W x 6 1/4"H x 3 3/8"D

321mm x 159mm x 86mm

Wall Opening: 11 3/4"W x 5 1/4"H x 2"D

298mm x 133mm x 51mm

UX76-BF-SM: Surface Mounted Dual Roll Dispenser with hood.

UX76-SF: Same as UX76-BF with satin finish.

UX76-SF-SM: Same as UX76-BF-SM with satin finish.

Optional U007 Theft Resistant Adapter: Prevents spindle from being removed until roll has been depleted.

INSTALLATION

Provide a wall opening at desired or specified area and coordinate with architect or contractor to avoid interference with pipes, vents etc. In wall. See specification for proper wall openings. Secure unit in wall opening with proper fasteners and clamps per application. Insert roller into roll core depress one side and install on posts.

Toilet Paper Dispensers: All dispensers that are to meet ADA code cannot have any type of controlled delivery. (4.16)

Mounting Clamps:

B-1 Clamp: Same as B-Clamp for UX76.

Note: Mounting Clamps are optional and must be ordered separately.

NOTES