



# U930

## Retractable Corner Shower Seat

Revision 03/11

JOB #:

ITEM #:

QUANTITY:

MOUNTING	HANDING	TYPE	SIZE	OTHER

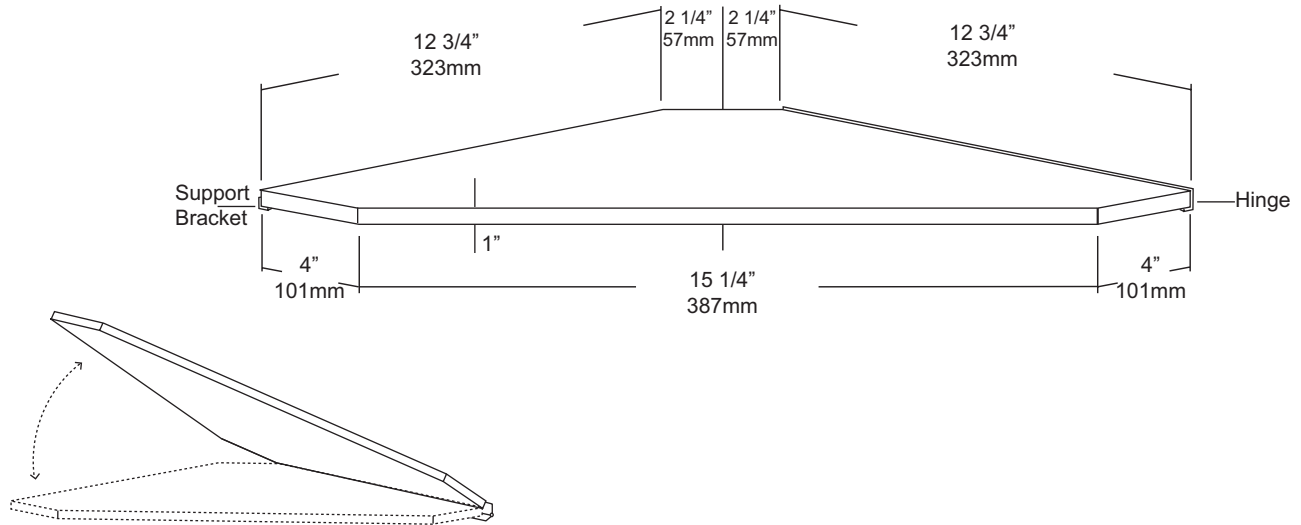

### SPECIFICATIONS

**Seat:** Fabricated of #16 gauge stainless steel double pan construction with a #4 satin finish with heliarc welded seams polished smooth. (Load capacity: 250 lbs) All corners are beveled.

**Support:** 1/8" stainless steel formed bracket (exposed mounting) is secured to wall surface and acts as a support opposite of hinged side.

**Hinge:** Heavy duty full length stainless steel hinge is welded to 1/8" formed bracket (exposed mounting) allowing raising and lowering of seat.

**Overall Size:** 15" x 15 1/4" x 15" x 1" thick  
**381mm x 387mm x 381mm x 25mm**

### INSTALLATION

Coordinate with contractor and architectural plans for pipes, vents etc in wall. Secure seat to proper backing and framing with proper fasteners per application. (Fasteners not supplied) If this seat is being secured for a security type application, proper security style fasteners should be used. (Not supplied) Proper mounting height above finished floor is 17" - 19". Check all state and local building codes.

Select mounting height above finished floor and secure support bracket with proper fasteners. Position seat at selected height in the lower position resting on support bracket. When seat is level transfer mounting points to hinged side. Secure hinged side and test the travel of the seat.

### NOTES